

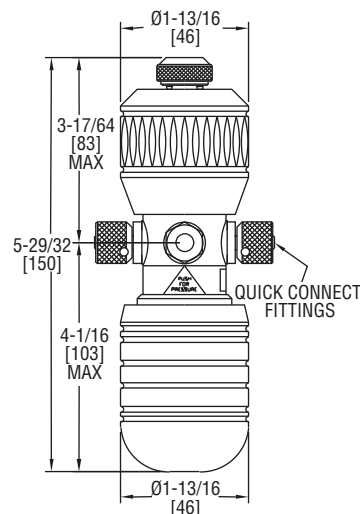

# Model HP Hand Pump

## Specifications - Operating Instructions



The Model HP Hand Pump provides a dual source of pneumatic pressure and vacuum for verifying the calibration of pressure instrumentation. Pump can generate pressures up to 45 psi (3 bar) and vacuum to -27" Hg (-910 mbar). The compact pump is designed for portability and single hand operation.

Model HP features a pressure relief valve and fine adjustment for control better than 0.0015 psi (0.1 mbar). Pump includes two 39" (1 m) hoses terminating in 1/4" female NPT connections and instruction manual.

**FIGURE 1 KEY:**

- 1 Pressure release valve
- 2 Fine adjustment control
- 3 Pressure/vacuum selector
- 4 Knurled "quick fit" connectors
- 5 Two flexible hoses to item under test and master instrument
- 6 NPT adaptor set
- 7 Pump handle
- 8 Pressure relief valve

**SPECIFICATIONS**

**Output Ranges:** -27" Hg to 45 psi (-910 mbar to 3 bar)

**Process Connection:** 1/4" female NPT (quick fit)

**Fine Adjustment:** Better than 0.0015 psi (0.1 mbar)

**Materials:** Nickel plated brass and anodized aluminum

**Weight:** 20 oz (587 g)

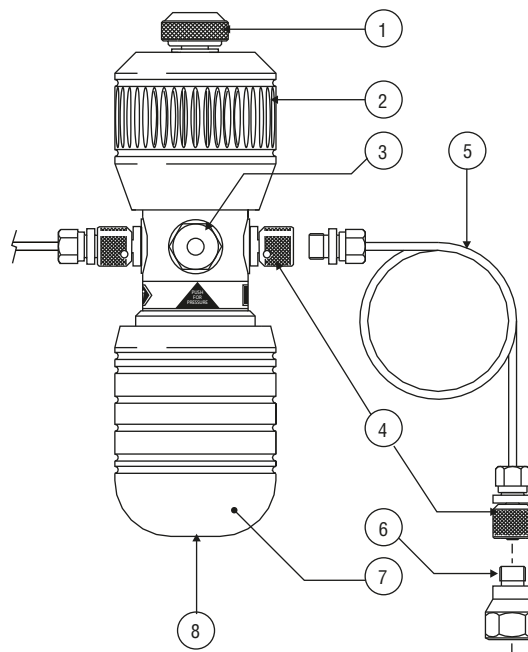

Figure 1

## DESCRIPTION OF KEY ITEMS

### Release Valve (1)

This can be used to reduce or release the pressure in the system. The rate of pressure reduction is dependent upon the degree of rotation when opening the valve. Minimal force is required to seal the system.

### Fine Adjustment Control (2)

The pressure generated can be finely adjusted by turning the fine adjustment control (2) in or out to increase or decrease pressure accordingly.

**Important: Do not wind the fine adjustment control (2) any further when the top of the pump body is visible.**

### Pressure/Vacuum Selection (3)

Press the selector (3) as indicated on the label to engage the desired mode. Ensure that the Release Valve (1) is open before changing mode.

### Pressure Ports (4)

The hoses (5) and adaptors (6) are fitted by simply screwing them into the connectors (4) by turning the knurled nut on the connector fully anti-clockwise.

### Adjustable Pressure Release Valve (8)

(For protection of sensitive instruments)

The maximum output pressure can be set using the pressure relief valve located inside the main Piston, accessed via the handle retaining screw (adjustment range between 50 mbar and 3 bar).

**Note: The pump should only be used for pressurizing small volumes due to its small displacement. If the pump has not been used for a period of time, it could be difficult to operate on the first stroke.**



**WARNING: Do not connect to external pressure source.**

## GUIDELINES FOR USE

### 1. Calibration/comparison against analog gage

**1.1** Connect a test gage using appropriate adaptor and sealing to one of the flexible hoses (5) or directly to body using adaptor (6).

**1.2** Connect item under test using appropriate adaptor and sealing to the second flexible hose (5) or directly to body using adaptor (6).

**Note: Adaptors tightened to a maximum torque of 15 Nm.**

**1.3** Screw fine adjustment control (2) in fully and then out 4-6 full turns.

**1.4** Screw pressure valve (1) in fully, tightening to ensure good seal.

**1.5** Using a flat blade screwdriver (2.5 mm wide max) adjust the pressure relief valve (8) to set the desired maximum output pressure. Turn the grub screw located in the main piston clockwise to increase or anti-clockwise to decrease the pressure setting.

**1.6** Operate handle (7) until the pressure is close to that finally required.

**1.7** Wind the fine adjustment control (2) in to increase pressure or out to decrease pressure until required pressure is reached.

**Note: The pressure may take up to 30 seconds to settle after increasing pressure due to thermodynamic effects, settling of seals and expansion of the flexible hose.**



**CAUTION: STOP unscrewing the fine adjustment control (2) when the top of the pump body becomes visible.**

**1.8** Reductions in pressure can also be achieved by careful use of the pressure release valve (1).

**1.9** Vacuum is achieved using the above procedure and having the pressure/vacuum selector (3) pushed completely towards the vacuum position.

**Note: Release pressure before changing mode.**

### 2. Fault Investigation

In the event that the pump appears to lose pressure then the procedure above should be repeated ensuring new seals are used, adaptors are tightened sufficiently and the pressure release valve (1) is tightened firmly.

**Note: The connections to the hand held test system are sealed with "o" ring or bonded seals and should not leak.**

**DO NOT** attempt to tighten the other fittings to the pump as this could lead to damage of sealed joints. When testing for leaks it may be noticed that air is drawn in or expelled from around the pressure/vacuum selector. This is normal and should cause no concern.