



HPM-100A

HPM-100A

User's Manual

# Power Meter



- Before using, please carefully read all contents and precautions of the manual.

- Contents -

Foreword

    Accessory

Before Using

    Warning, Upon Having a Problem Calibration

    Other Safty Precaution

Chapter 1. Get Started

Chapter 2. Part Names and Functions

    2.1 Front View

    2.2 Side View

    2.3 LCD Screen View

    2.4 Initial Setting Value

    2.5 Display Font

Chapter 3. Overview, Specifications, Function

    3.1 Product Introduction

    3.2 General Features

    3.3 General Specifications

    3.4 Technical Specifications

    3.5 Setting Menu Tree

    3.6 Measurement Item Display

    3.7 Current Range Setting

    3.8 Overvoltage · overcurrent input warning

    3.9 HOLD Function

    3.10 Key Lock function

    3.11 Back Light Function

    3.12 Measurement of Watt-Hour(Wh)

        Cautions at the time of measuring Watt-Hour(Wh)

    3.13 Setting electricity charges and CO2 emissions

    3.14 Green Coordinator (Function to calculate a monthly and yearly estimates for electricity usage, electricity charges, and CO2 emissions)

Chapter 4. PC Communications (RS-232C) Set Up & Circuit Diagram

- 4.1 RS-232 Communications Setting
- 4.2 How To Change Transmission Speed
- 4.3 Circuit Diagram

Chapter 5. GUI Program & Communications Protocol Specifications

- 5.1 GUI Program
- 5.2 Support Protocol & Common Communications Specifications
- 5.3 How To Change Communications Protocol
- 5.4 AD.01 Bus Protocol Specifications
- 5.5 AD.02 Bus Protocol Specifications
- 5.6 DP Bus Protocol Specifications

Chapter 6. Data Logging

- 6.1 General specification
- 6.2 Time Setting Mode
- 6.3 Run/Stop Mode
- 6.4 Data Load

Chapter 7. Maintenance

How to Replace a Fuse,  
Contact Information.

## Foreword

First, we would like to sincerely thank you for your selection of AD POWER products and wish your company every success in the future. Before using, please make sure to completely read and understand the product, PC communication, and GUI program manuals in order to maximize your work efficiency. Also, please contact us if you have any problem or instrument failure upon using our products. We promise to put our best efforts into solving the problem.

All AD POWER employees.

## Accessory

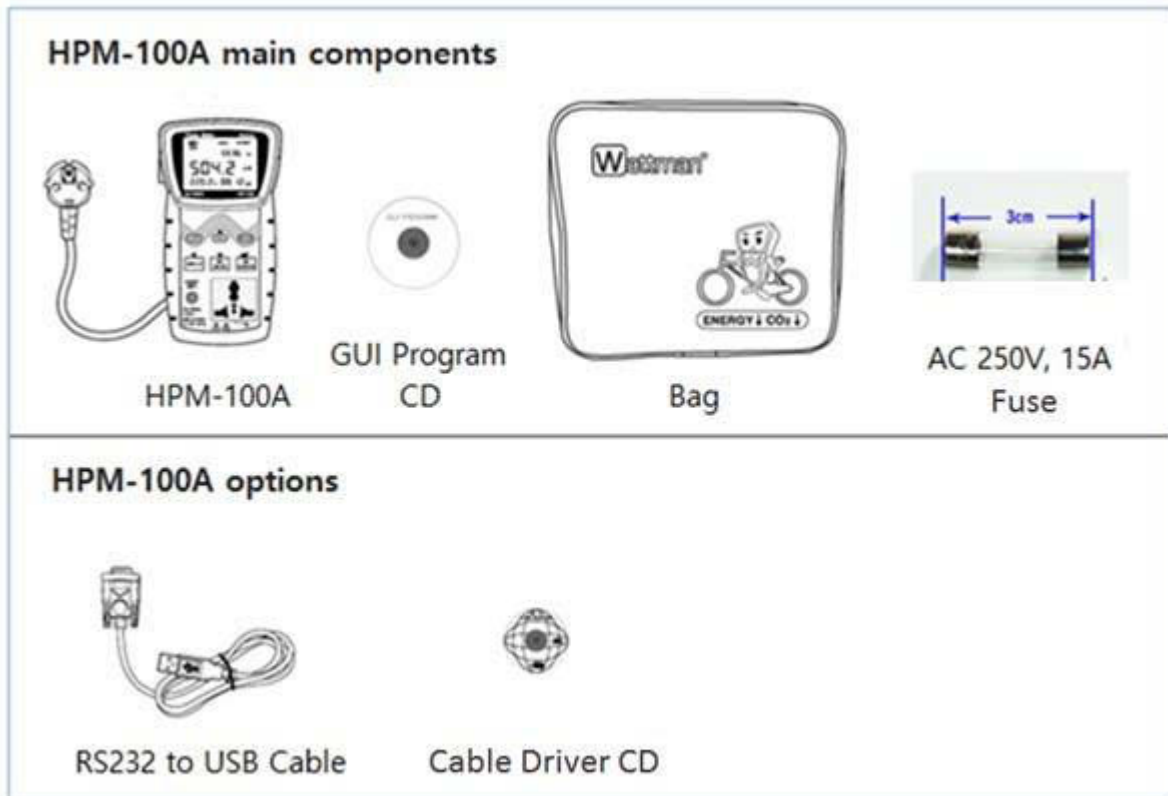

## Chapter 1 (Before using)

### Warning



Before using, please make sure to understand and follow the safety precautions.

This equipment follows safety standards including IEC 61010-1 and CE mark. However, it is to be used in measuring a high voltage; thus, it can cause an accident or a failure of equipment upon careless handling and operation. Please make sure to thoroughly read and understand the manual before you use this equipment.

In case of an accident, we shall not be held responsible unless it is caused by our product's malfunction.

### Upon having a problem

- First, please refer to the manual and follow the safety precautions and instructions carefully.
- The product warranty is effective for one year from the date of purchase.
- However, if the customer's negligence, failure to follow the instructions, or a natural disaster causes the problem, the product warranty will not cover any expenses for required service.
- Please ground for protection from high voltage.
- Improper use of this equipment may cause an accident such as electric shock.
- Even after the warranty is expired, it is recommended and safer to have the equipment repaired in our service center.

(Service Center : +82-32-234-3791)

### Calibration

We recommend that calibration should be performed approximately once a year according to the specifications

### Other safety precautions

This equipment is designed in accordance with CE CAT II and FCC safety standards. Yet, please carefully read and follow the following instructions for safe use and operation.

- The maximum voltage and current is AC 250V and 15A. Exceeding its maximum voltage and current may cause a serious damage or accident.
- Measuring the load in the range from AC 10A to 15A (less than 30 seconds on each measuring,) please maintain at least 10 minute intervals in-between measurements. Any electric current less than 10A can be measured for a long period.
- If this equipment is used more than 30 seconds when measuring an electric current between 10A ~ 15A, "OL" will appear on the display and an alarm will sound to warn the user and avoid a danger.

When it occurs, wait for 10 minutes and resume the measurement.

- The power supply voltage of the equipment should not exceed 90~250V (SMPS) before turning on.
- If you notice a smoke, smell, or sound while using the equipment, immediately turn off the power and consult our service center or head office.
- This equipment should be used in a temperature and humidity of less than 10°C ~ 50°C/RH65% and kept away from a wet towel, dust, and damp place.
- A strong electronic or magnetic field can cause an error in measurement.
- Avoid a hazardous gas and try not to step on the cable nor twist it.
- For accurate measurement, turn on the equipment and let it warm up for more than 5 minutes.
- For accurate measurement, beware of overheating of the equipment and provide a sufficient ventilation space.
- When moving this equipment, please use its original packing materials and boxes. If not, use a plastic bag to seal it from external moisture and lay more than 20mm of a shock absorbent on the bottom before packaging.
- If the back cover is not closed completely, never use the equipment.
- Make sure that the supply voltage (source voltage) and the voltage of the appliance that is to be measured are the same.

## Chapter 2 (Names and function of each part)

### 2-1 Front View

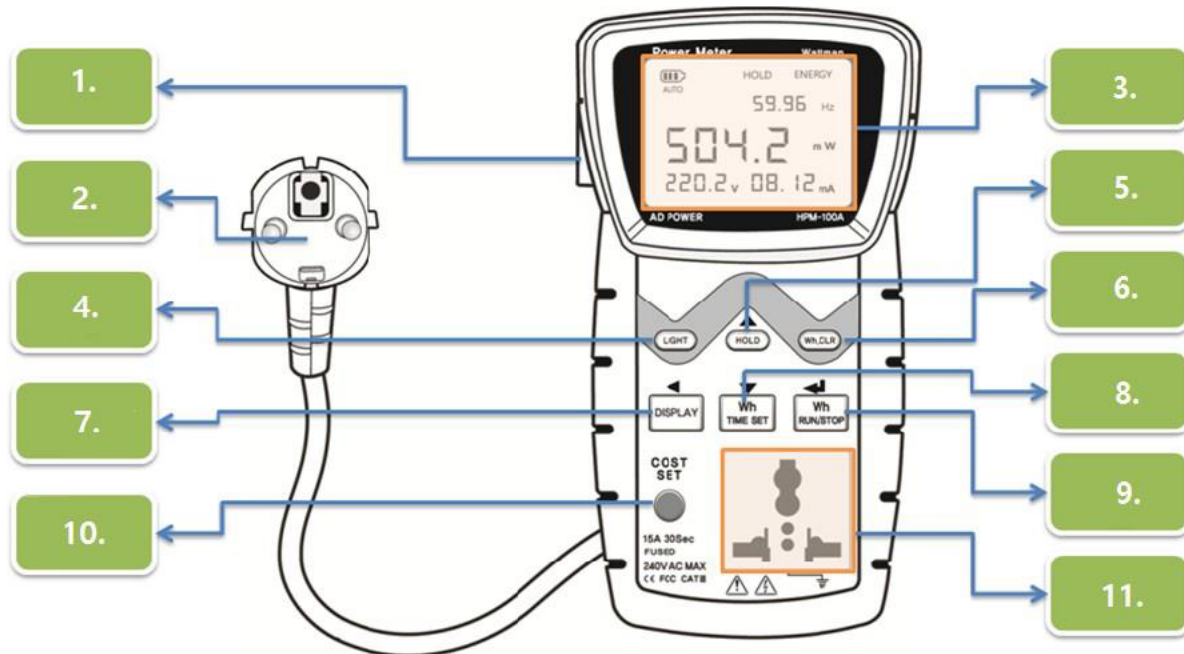

1. RS 232 port : Communication port (RS232C)
2. Power cable (1.5m) : Power cable (For Europe)
3. LCD : AC, voltage, current, power factor, frequency, watt hours, carbon emissions, and electricity charges can be shown.
4. Backlight button : LCD backlight on/off (it helps you to see in a dark place)
5. Stop button : Temporarily pause the measurement, while using the Key Lock
6. Zero setting button : In the watt-hour mode (Wh,) when the equipment is not accumulating the wattage, press the button for more than 3 seconds. It erases the previous measured watt hours, initializes the setting with a beep sound, and enables you to perform a new measurement.  
 ※For the data logging equipment, it can also erase data saved in the internal memory.
7. Mode change button : Active wattage (W), Power factor (PF), Watt hours (Wh), Logging (data logging equipment), Reactive power (Var), CO2 emissions (kg), Electricity charges (won) mode conversion button.
8. Time setting button : Period in which the watt hours is to be calculated (00.hr : infinite, from 1hr to 24hrs) setting

9. Watt hour start/stop button : watt hour operation start/stop in the watt hours mode (LCD displays "ENERGY")  
 ※For the data logging equipment, it is used to start/stop logging.
  10. CO2 setting value change button : Electricity charges and CO2 emission unit setting (in the watt-hour mode)  
 ※In all other modes, press and hold it to enter the setting mode.
  11. Receptacle : Secondary receptacle (plug in the appliance to be measured)
- All buttons related to watt hour can be accessed in the watt-hour mode.

## 2-2 Side View



1. RS 232 port : Communication port (RS232C/ D-SUB 9Pin)
2. 2 stage folding stand : Folding stand (2 stages)
3. Safety rubber cap : Safety rubber cap (safety cover - please uncover the cap before measuring)



### 2-3 LCD Screen View

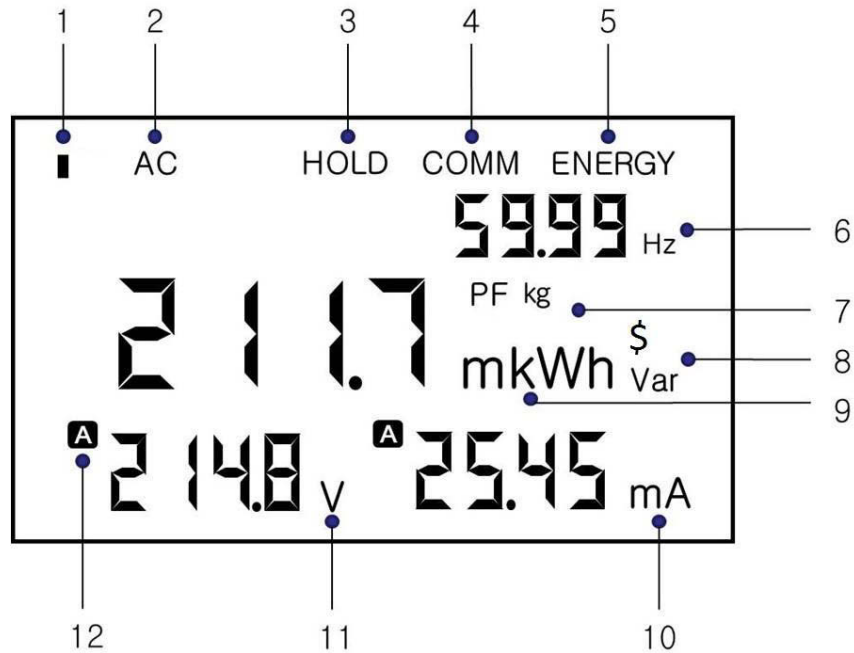

- 1) Data logging indicator: it blinks when data logging
- 2) Input power indicator: AC only
- 3) Pause indicator: pause displaying measurement / It blinks when the Key Lock is activated
- 4) Communication indicator: PC communication indicator
- 5) Measuring process indicator: when calculating watt hour, it displays "ENERGY"
- 6) Frequency indicator: it displays the measured frequency
- 7) It displays power factor, CO2 emissions, electricity charge unit
- 8) It displays the measured reactive power unit
- 9) It displays the measured active power and watt hour unit
- 10) Current indication: it displays the current of the appliance
- 11) Voltage indicator: it displays the voltage of the appliance
- 12) Auto range indicator: it operates the range automatically

## 2.4 Initial Setting Value

- 1) Communication protocol: AD.02 (for Wattman Viewer)
- 2) Communication speed: 9600bps
- 3) Electric power integration time: 1hour
- 4) Power rate: 188won (per kWh)/ varies with country.
- 5) Generation of carbon dioxide (Co2): 0.425kg (per kWh)
- 6) Initial value related to data logging
  - Data logging storage item: Voltage(V), Current(A), Active power(W), Electric power(Wh), Power factor(PF), Frequency(Hz),
  - Logging Interval: 1 second
  - Data logging mode: Run/Stop mode (No setting time)

## 2.5 Display font

0	0	A	A	K	K	U	U
1	1	B	b	L	L	V	V
2	2	C	c	M	M	W	W
3	3	D	d	N	N	X	X
4	4	E	E	O	O	Y	Y
5	5	F	F	P	P	Z	Z
6	6	G	G	Q	Q	" + "	" + "
7	7	H	H	R	R	" - "	" - "
8	8	I	I	S	S	" × "	" × "
9	9	J	J	T	T	" ÷ "	" ÷ "

## Chapter 3 Overview

### 3-1 Product information

It has a function to measure consumed/standby power in accordance with KS C IEC 62301 international standby power measurement standards. With its plug & play feature, this equipment can display 4 different information when an appliance is plugged in its international size multi-receptacle located on the front side of the equipment. It can easily measure and calculate AC voltage, current, power, power factor, frequency, watt hours, electricity charges, and CO2 emissions. As power analysis tools, it has real time graph and statistic PC program, and data logging function that uses internal memory without PC, thus support users to write official report.

Also, it is a NEP certified product that has been selected as a world-class product and excellent procurement product by Korean government.

### 3-2 General features

- Applied with KS C IEC 62301 standards
- Applied with EN 61010-1 standards
- Precise low-power, low power factor measurement
- No Battery and No Adaptor
- Neither battery nor adaptor needed
- Timer setting feature : built-in (1hour ~ 24hours)
- Consumed and standby power measurement (0.009W ~ 3,750W)
- Four elements such as voltage, current, power, and frequency can be measured and displayed simultaneously
- A variety of metrics  
(V, A, W, Wh, power factor, electricity charges, CO2 emissions, etc)
- Electricity charges can be set by using a button
- Easy and convenient access with the international size multi-receptacle (Plug & Play system)
- Free support on GUI Program  
(PC real time graph, statistic, analysis, data collection setting)
- Dynamic & Multi data logging

(Max. 400days, Logging interval 1 second~, 9600~2000 sets, Max. 999 Multi logging)

### 3-3 General specifications.

- Standard Testing Temperature : 23 °C, ( $\pm 4$  °C)
- Effective Test Temp & Humidity: 10 °C ~ 50 °C, (30 ~ 95%)
- Storage Temperature : 10°C ~ 60°C
- Material of Case : ABS Resin
- Sampling Time : 2 count / sec
- Response Time :  $\approx$  1.5 sec
- Weight & Dimensions : 115(W) X 200(H) X 45(D)mm, approximately 650g

### 3-4 Technical specifications.

- Voltage: AC 90V ~ 250V,  $\pm 0.3\%$ rdg.  $\pm 3$ dgt
- Current : AC 100uA ~ 15A
  - Current: 100uA ~ 5mA,  $\pm (0.5\%$ rdg + 3dgt)
  - Current: 5mA ~ 10A,  $\pm (0.3\%$ rdg + 3dgt)
  - Current: 10A ~ 15A,  $\pm (0.4\%$ rdg + 3dgt)
- Power : AC 0.009W ~ 3,750W (PF 1.0)
  - Active Power: 0.009W ~ 0.45W,  $\pm (0.5\%$ rdg + 3dgt)
  - Active Power: 0.45W ~ 2,600W,  $\pm (0.4\%$ rdg + 3dgt)
  - Active Power: 2,600W ~ 3,750W,  $\pm (0.5\%$ rdg + 3dgt)
- Power factor: Power Factor :  $\pm 0.001$  ~ 1,  $\pm (0.5\%$ rdg + 3dgt)
- Frequency: 50Hz ~ 1,000Hz,  $\pm (0.5\%$ rdg + 3dgt)

### 3-5 Setting Menu Tree

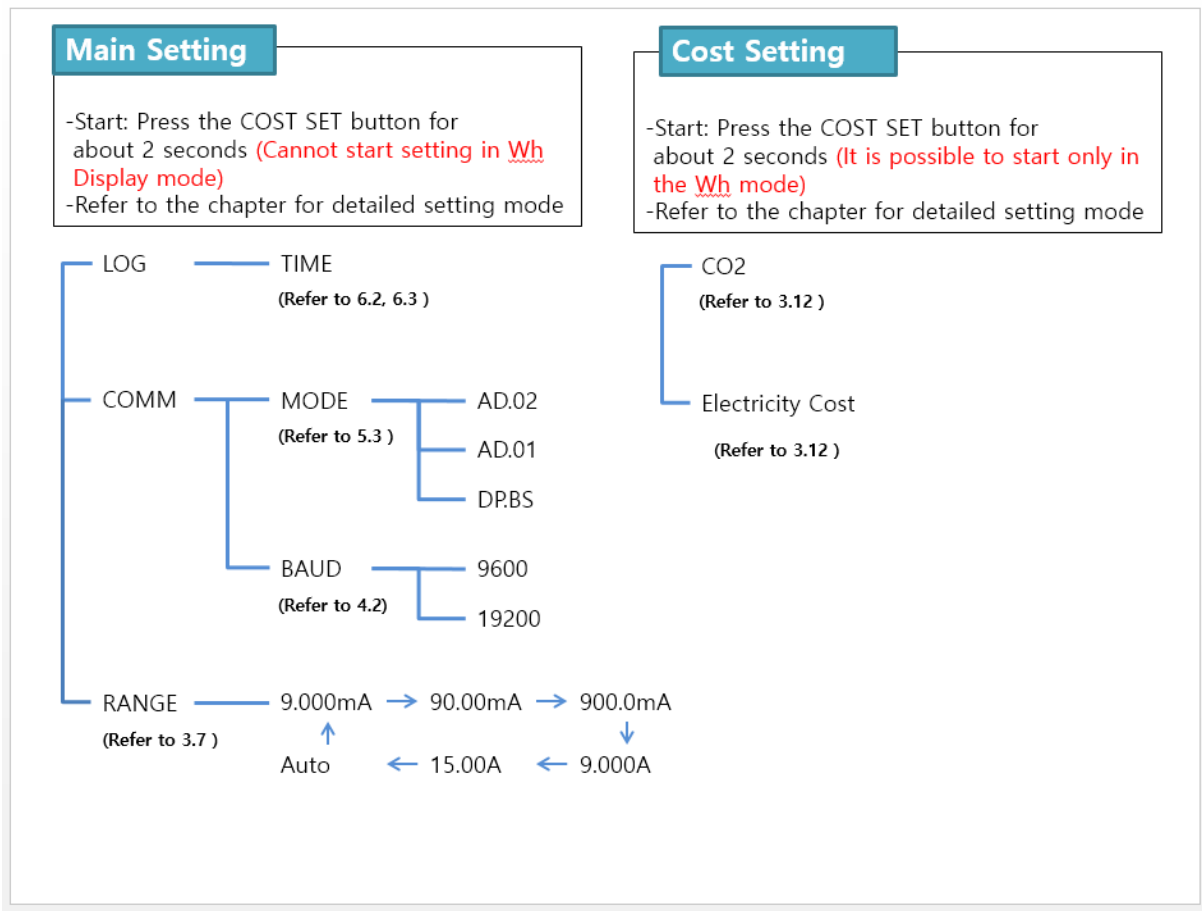

### 3-6 Measurement item display

First of all, check if the supply voltage (source voltage) is the same as the rated voltage of the device to be measured. Basically, "Power consumption / Standby power measuring instruments" can measure up to 9mW ~ 3,750W.

(Measuring power consumption and standby power)

- 1) If power is supplied, you can see voltage, current, power, and frequency values on LCD at the same time.
- 2) At the time of measurement, connect the load, which you want to measure, into the outlet on the front of Wattman.
- 3) By using the "DISPLAY" button, you can gradually check active power → power factor → Wh → data logging → reactive power → carbon emission quantity → power rate

### 3.7 Current Range Setting

This instrument provides both auto and manual range measurement in current channel. The voltage channel has auto range measurement use only. Refer to the following current range configuration table.







※The default range after power on is auto range.

Channel	Range	RMS value
AC current	9.000mA	0.000mA~9.999mA
	90.00mA	00.00mA~99.99mA
	900.0mA	000.0mA~999.9mA
	9.000A	0.000A~9.999A
	15.00A	00.00A~15.00A



※Manual range measurement is necessary when you need quick measurement response or pulse input. When the range is set to auto, the range may be adjusted frequently if a waveform such as a pulse is input. In such a case, set the range manually.

1) How to set manual current range.

<p>1. </p>	<p>2. </p>	<p>3. </p>
<p>In order to select manual range, press the "RANGE" button for a few seconds.</p>	<p>When the setting mode is open, press the "Wh TIME SET" button while "RANGE" on the screen blinks</p>	<p>Press the "Wh RUN/STOP" button while "RANGE" on the screen blinks</p>
<p>4. </p>	<p>5. </p>	<p>6. </p>
<p>Operating current range will be showed</p>	<p>Select the Range you want and press the "Wh RUN/STOP" button.</p>	<p>The <b>A</b> mark will disappear when you select a manual range.</p>

2) Manual current range LCD display.

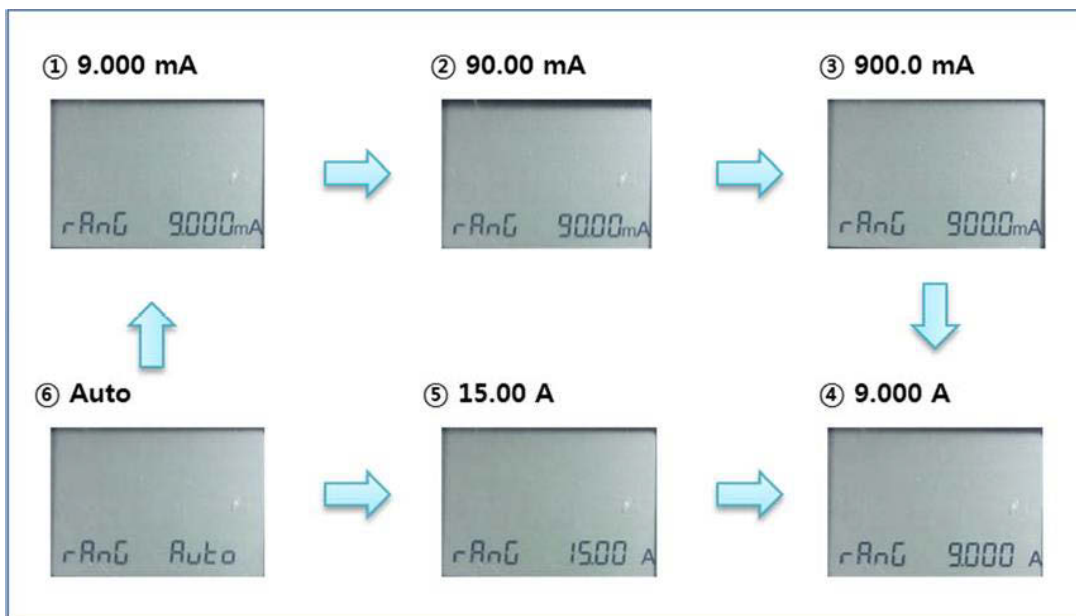

### 3) Manual Range Overflow

If an input current exceeds the maximum permissible RMS limit, alarm will sound and -OL- will be displayed. You must increase the manual range or change to auto range in this case.

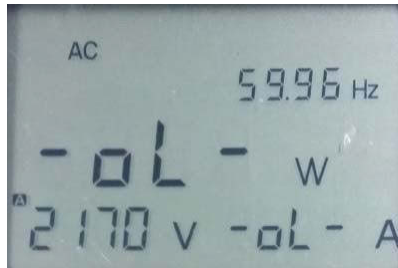



### 3-8 Overvoltage - overcurrent input warning

If an input voltage or input current exceeds the maximum permissible limit, an alarm will sound or an alarm lamp will flicker.

- 1) If more than 500.0 V (AC voltage) is inputted, the -OL- flickering and the warning sound occur.
- 2) If more than 15.0 A (AC current) is inputted, the -OL- flickering and the warning sound occur.
- 3) If 12.0 A ~ 15.0 A (AC current) is inputted, the flickering occurs after 5 seconds and the warning sound occurs after 10 seconds.



※The maximum rated voltage and current are AC 250V and 15A respectively. If they exceed these limits, it may cause serious damage or accident. When the measurement load capability is between AC 10A and 15A (within 30 seconds at the time of every measurement), it is recommended that the interval of every measurement should be at least 10 minutes.

If the current is less than 10A, it is possible to measure for a long time.

### 3-9 Hold function

When the "HOLD" button is pressed, it temporarily saves and displays the measured data. However, it does not stop its measuring process (it only displays the measured data when the "HOLD" button was pressed.)

RS-232C communication data, integration accumulation, and other functions are in a normal operation. Just press the "HOLD" button again to turn off the hold function.

### 3-10 Key Lock function

Press the "HOLD" button for more than 3 seconds. Then, "HOLD" indicator will flash on the screen. At this point, no button except the "DISPLAY" button will be functional. Press the "HOLD" button for more than 3 seconds again to turn it off

### 3-11 Back Light function

It turns on/off the backlight on the LCD.

### 3.12 Measurement of Watt-Hour(Wh)



Put the plug of measured product in multi-outlet at the below right below of the product after power in.



Change to Watt-hour (Wh) mode by pressing DISPLAY button.



Set time by pressing Wh TIME SET button.



Press Wh RUN/STOP button.



"Energy" sign is displayed at the above right of LCD screen and start integration.



After wattage integration press DISPLAY button and change to CO<sub>2</sub> emission mode.



Confirm CO<sub>2</sub> emission quantity.



Change to electricity COST mode, when press DISPLAY button.



To initialize Data, Press Wh.CLR button For 3 Seconds.

### ※Cautions at the time of measuring Watt-Hour(Wh)



Please be noted that Watt-Hour is activated as follows in order to avoid confusion in connection with PC communication data logging. If Wh function is used only, it is not applicable in this cautions.

- ① While communicating with PC or data logging, you cannot operate the Wh function (Wh start · stop, time setting, and initialization).
- ② If you start communication after starting Wh, the Wh time stops and the Wh automatically stops at the time when PC communication stops.
- ③ If you start data logging during Wh, the Wh time stops and the Wh automatically stops at the time when data logging stops.
- ④ If you start logging after selecting the Wh in the data logging storage item, the Wh starts together. If you stop data logging, the Wh stops, too.

### 3-12 Setting electricity charges and CO2 emissions

Wattman has a function to convert a calculated watt hours to electricity charges and CO2 emissions.

Electricity charges and CO2 emissions per 1kWh can be adjusted when needed.

#### 1) Measuring electricity cost

The electricity charges is set based on the general households' electricity usage (approximately 300kWh) with a rate of 168 Won per 1 kWh.

Example) Electricity charges(₩) = 1kWh x 168(₩)

Different electricity charge rates can be applied by the set key

#### 2) Measuring CO2 emissions

CO2 emissions from fossil fuel (ex. petroleum) to generate 1kWh: 0.425kg (from the 2005 study of Korea Institute of Energy Research)

Example) CO2 emissions (kg) = 1kWh x 0.425 kg

Different CO2 emission rates can be applied by the set key

#### 3) Setting method

- If you press "COST SET" button, the carbon dioxide emission setting value is indicated on the display. (It is possible to set the value only in the electric power display mode.)
- Change the setting value with the use of Up(▲), Down(▼), Left(◀) Enter(↵) buttons gradually from the first digit of the number.
- Save the setting by pressing the Enter(↵) button. (If you do not press the Enter, it is not saved.)
- After saving the carbon dioxide emissions, set the power rate. (The setting method is the same.)
- After completing the setting, press "COST SET" button to finish the setting. Or if you operate nothing for about 10 seconds, the setting is finished

### 3-13 Green Coordinator (Function to calculate a monthly and yearly estimates for electricity usage, electricity charges, and CO2 emissions)

When you press the "HOLD" button and the "DISPLAY" button in the active power mode, Wattman will calculate and show a monthly and yearly estimate for watt hours usage, electricity charges, and CO2 emissions.



- ① Estimates of monthly watt hours usage
- ② Estimates of yearly watt hours usage
- ③ Estimates of monthly electricity charges
- ④ Estimates of yearly electricity charges
- ⑤ Estimates of monthly CO2 emissions
- ⑥ Estimates of yearly CO2 emissions

## Chapter 4 PC communication (RS232C) setting and circuit diagram

### 4-1 RS232C communication setting

- 1) Communication port: Connect a serial communication port or USB cable to the port that has been created.
- 2) Communication speed: 9600, 19200
- 3) Stop bit: 1
- 4) Parity, Flow control: No

### 4-2 How to change a communication speed

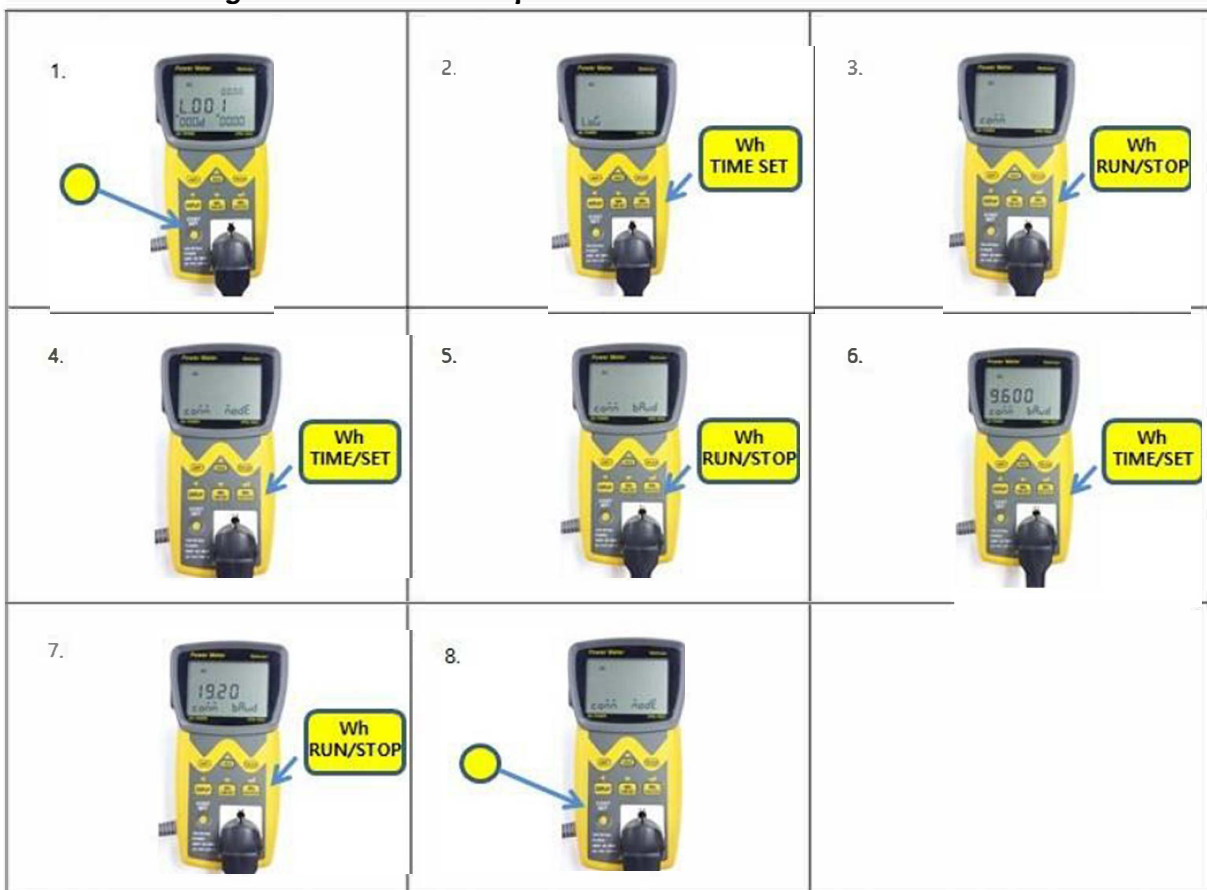

1. In order to change a communication speed, press the "COST SET" button for a few seconds.
2. When the setting mode is open, press the "Wh RUN/STOP" button while "LOG" on the screen blinks.
3. Press the "Wh RUN/STOP" button while "COMM" on the screen blinks.

4. Press the "TIME/SET" button while "MODE" on the screen blinks.
5. Press the "Wh RUN/STOP" button while "BAUD" on the screen blinks.
6. The initial value is 9600. When you press the "Wh RUN/STOP" button, the number, "19200," on the screen will blink.
7. Select the communication speed you want and press the "Wh RUN/STOP" button. Then, the communication speed will be set.
8. Exit the setting mode by pressing the "COST SET" button.

#### 4-2 Circuit diagram

- 1) HPM-100A has the following circuit diagram for the isolation from PC.
- 2) Therefore, when you connect RS232C cable, connect it with the number 2 (RX), 3 (TX), 4 (Power), 5 (GND), and 7 (GND).

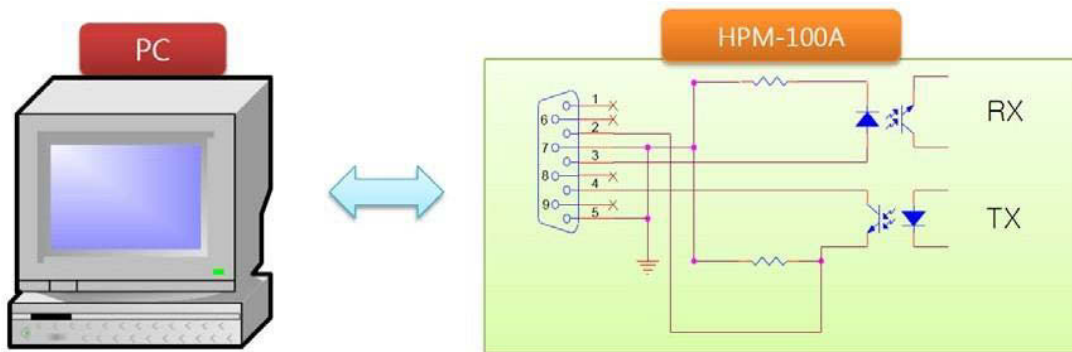

# Chapter 5 GUI program and communication protocol specifications

## 5.1 GUI program

GUI program CD is distributed free of charge or can be downloaded from our homepage. Users can use the program as follows. Users can perform a real-time monitoring, saving, analyzing, and generating an output. Please refer to GUI manual for more information.

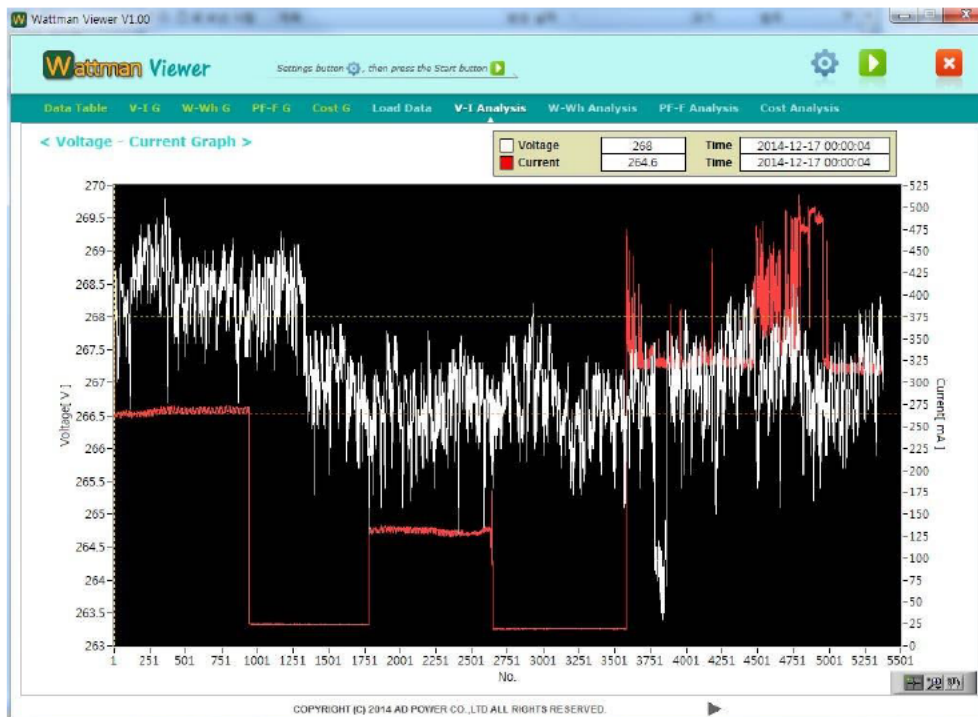

## 5.2 Supporting protocol and common communication specifications

This product supports 3 protocols, AD.01, AD.02, and DP.BUS. Thus, a user programmer can read and control the measurement items of the equipment after applying a communication protocol to the application program.



### 5.3 How to change the communication protocol

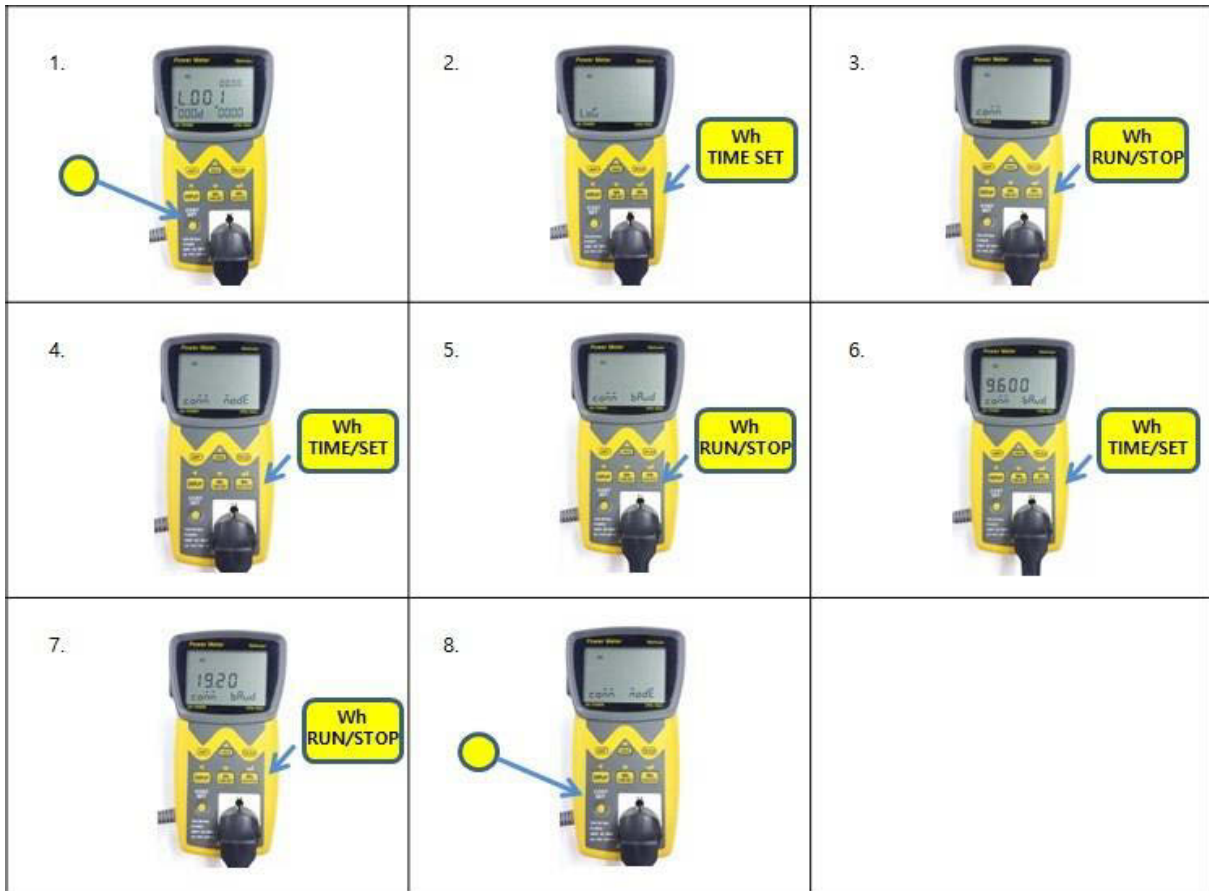

1. In order to change the communication protocol, press the "COST SET" button for a few seconds.
2. When the setting mode is open, press the "Wh RUN/STOP" button while "LOG" on the screen blinks.
3. Press the "Wh RUN/STOP" button while "COMM" on the screen blinks.
4. Press the "Wh RUN/STOP" button while "MODE" on the screen blinks.
5. The initial value is AD.02. When you press the "Wh TIME SET" button, "AD.01" on the screen will blink.
6. When you press the "Wh TIME SET" button, "DP.BUS" on the screen will blink.
7. Select a communication protocol you want and press the "Wh RUN/STOP" button, then the communication protocol will be set.
8. Exit the setting mode by pressing the "COST SET" button.

### 5.4 AD.01 bus protocol specifications

- 1) Communication speed: 9600 bps, 19200 bps
- 2) Users can easily receive measurement items by using AD Power protocol. All data can use ASCII code.
- 3) When PC sends the uppercase letter 'S', the measurement data will continuously be received in approximately 0.5s cycle. It will end when PC sends the uppercase letter 'E'.
- 4) 'S' means the start of the data set, and 'E' means the end of the data set.
- 5) The maximum size of the data for each item is 5 digits.
- 6) The first 4 digits are effective numbers, and the last digit indicates the position of decimal point as shown in the illustration.
- 7) "Vo, Am, Wa, Wh, Pf, and Hz" mean Voltage, Ampere, Wattage, Watt hours, Power Factor, and Hertz respectively.  
The following example is ASCII data converted from 219.3V, 145.7mA, 129.5W, 146.2Wh, 40.4PF, and 599.1Hz.

  Effective numbers      Unit

S: 2193Vo: 1452Am: 1295Wa: 1462Wh: 404Pf: 5991Hz

  : Applied unit

	Units								
	1	2	3	4	5	6	7	8	9
Volt	0.000 V	00.00 V	000.0 V	-	-	-	-	-	-
Ampere	00.00 mA	000.0 mA	0.000 A	00.00 A	000.0 A	0000 A	-	-	-
Watts	0.000 mW	00.00 mW	000.0 mW	0.000 W	00.00 W	000.0 W	0.000 kW	00.00 kW	000.0 kW
Wh	0.000 Wh	00.00 Wh	000.0 Wh	0.000 KWh	00.00 KWh	000.0 KWh	0000 KWh	-	-
PF	-	-	-	0.000 PF	-	-	-	-	-
Hz	00.00 Hz	000.0 Hz	0.000 KHz	-	-	-	-	-	-

### 5.4.1 Supporting GUI program

AD.01 Bus supports HPM-100 Viewer PC program, and it can be downloaded free of charge from [www.adpower21.com](http://www.adpower21.com).

HPM-100 Viewer PC program supports only 9600 bps.

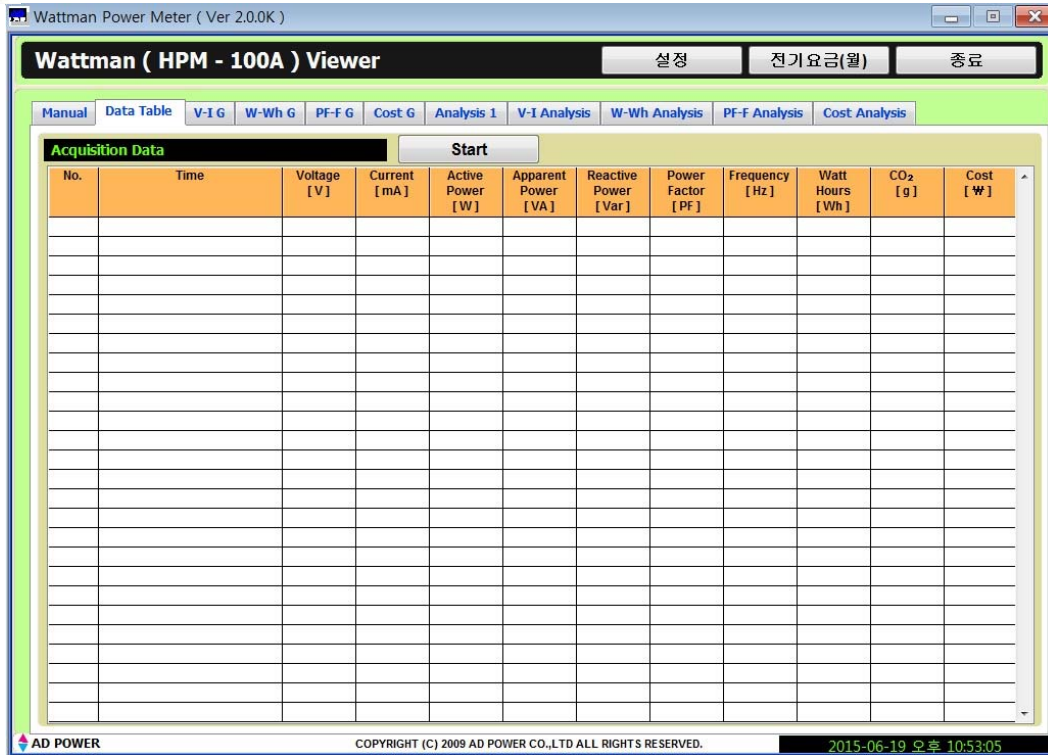

## 5.5 AD.02 Bus protocol specification

Communication speed : 9600, 19200 bps.

Command Rx over time between byte and next byte: 1 second.

### 5.5.1 Data transmission start command

Commend	Size of byte	Function
'S'	1	Command
'#'	1	Closer

- 1) Transmitting data protocol: It continuously transmits data in an approximately 0.5s cycle. In a set of data, 'S' means the start of the data, and 'E' means the end of the data.
- 2) Each item of data to be transmitted is up to six digits.
- 3) The first 5 digits are effective numbers, and the last digit indicates the position of decimal point as shown in the illustration.
- 4) "Vo, Am, Wa, Wh, Pf, and Hz" mean Voltage, Ampere, Wattage, Watt hours, Power Factor, and Hertz respectively.  
The example below is the ASCII data converted from 219.30V, 145.70mA, 12.910W, 14.680Wh, 0.4040Pf, and 59.980Hz respectively

S: 219303Vo: 145702Am: 129105Wa: 146802Wh: 40404Pf: 599801Hz E

Effective numbers Unit

: Applied unit

	Units									
	0	1	2	3	4	5	6	7	8	9
Volt		0.0000 V	00.000 V	000.00 V	-	-	-	-	-	-
Ampere	0.0000 mA	00.000 mA	000.00 mA	0.0000 A	00.000 A	000.00 A	0000 A	-	-	-
Watts		0.0000 mW	00.000 mW	000.00 mW	0.0000 W	00.000 W	000.00 W	0.0000 kW	00.000 kW	000.00 kW
Wh		0.0000 Wh	00.000 Wh	000.00 Wh	0.0000 KWh	00.000 KWh	000.00 KWh	0000 KWh	-	-
PF		-	-	-	0.0000 PF	-	-	-	-	-
Hz		00.000 Hz	000.00 Hz	0.0000 KHz	-	-	-	-	-	-

### 5.5.2 Data transmission stop command

Command	Size of byte	Function
'E'	1	Command
'#'	1	Closer

### 5.5.3 Watt hour control command

Command	Size of byte	Function
'W'	1	Command
'0' or, '1', or '2'	1	'0': starts the watt hour. '1': stops the watt hour. '2': resets the accumulated values from the watt hour and the watt hour time into 0. .
'#'	1	Closer



### 5.5.4 Supporting GUI program

AD.02 Bus supports Wattman Viewer program, and it can be downloaded free of charge from [www.adpower21.com](http://www.adpower21.com).

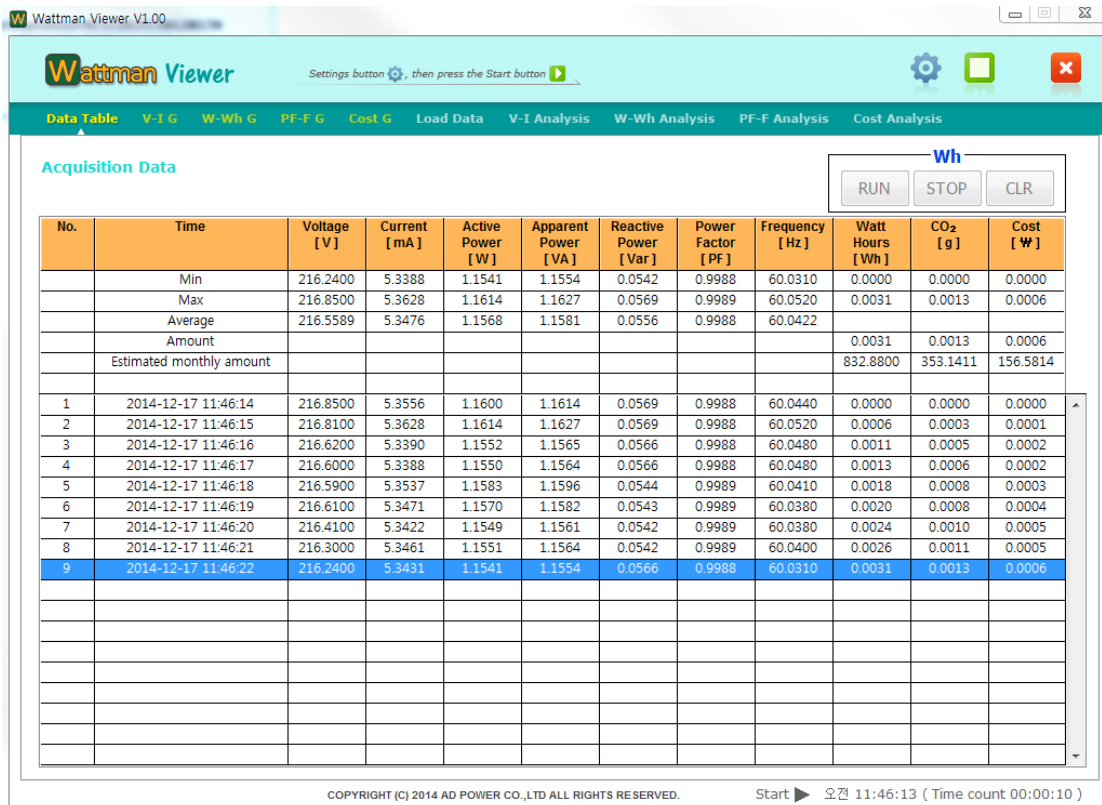
Yet, Wattman Viewer program supports 9600 bps and 19200bps, which can be changed in the setting.



**Wattman Viewer V1.00**

Settings button , then press the Start button 

**Wh**

RUN STOP CLR

No.	Time	Voltage [V]	Current [mA]	Active Power [W]	Apparent Power [VA]	Reactive Power [Var]	Power Factor [PF]	Frequency [Hz]	Watt Hours [Wh]	CO <sub>2</sub> [g]	Cost [₩]
	Min	216.2400	5.3388	1.1541	1.1554	0.0542	0.9988	60.0310	0.0000	0.0000	0.0000
	Max	216.8500	5.3628	1.1614	1.1627	0.0569	0.9989	60.0520	0.0031	0.0013	0.0006
	Average	216.5589	5.3476	1.1568	1.1581	0.0556	0.9988	60.0422			
	Amount								0.0031	0.0013	0.0006
	Estimated monthly amount								832.8800	353.1411	156.5814
1	2014-12-17 11:46:14	216.8500	5.3556	1.1600	1.1614	0.0569	0.9988	60.0440	0.0000	0.0000	0.0000
2	2014-12-17 11:46:15	216.8100	5.3628	1.1614	1.1627	0.0569	0.9988	60.0520	0.0006	0.0003	0.0001
3	2014-12-17 11:46:16	216.6200	5.3390	1.1552	1.1565	0.0566	0.9988	60.0480	0.0011	0.0005	0.0002
4	2014-12-17 11:46:17	216.6000	5.3388	1.1550	1.1564	0.0566	0.9988	60.0480	0.0013	0.0006	0.0002
5	2014-12-17 11:46:18	216.5900	5.3537	1.1583	1.1596	0.0544	0.9989	60.0410	0.0018	0.0008	0.0003
6	2014-12-17 11:46:19	216.6100	5.3471	1.1570	1.1582	0.0543	0.9989	60.0380	0.0020	0.0008	0.0004
7	2014-12-17 11:46:20	216.4100	5.3422	1.1549	1.1561	0.0542	0.9989	60.0380	0.0024	0.0010	0.0005
8	2014-12-17 11:46:21	216.3000	5.3461	1.1551	1.1564	0.0542	0.9989	60.0400	0.0026	0.0011	0.0005
9	2014-12-17 11:46:22	216.2400	5.3431	1.1541	1.1554	0.0566	0.9988	60.0310	0.0031	0.0013	0.0006

COPYRIGHT (C) 2014 AD POWER CO.,LTD ALL RIGHTS RESERVED. Start ▶ 오 11:46:13 ( Time count 00:00:10 )

## 5.6 DP DP Bus protocol specification

- 1) DP Bus is unable to use Wattman Viewer program. However, it is added to show the value of the instrument using a communication emulator such as the hyper terminal.
- 2) Communication speed: 9600bps, 19200 bps.
- 3) Command Rx over time between byte and next byte: 1 second.

### 5.6.1 Data transmission start command

Command	Size of byte	Function
'S'	1	Command
'#'	1	Closer

- 1) It will be continually received in around 0.5s cycle, and 'S' means Start and 'E' means End of a data set. (Data send interval can be modified by command)
- 2) Each item's sent data include 5-digit real number of values and units, and will use ASCII values to display on the product.

An example below is ASCII data that is received 219.30V, 145.70mA, 12.910W, 14.680Wh, 0.4040Pf and 59.980Hz.

**S: 219.30 V 145.70 mA 12.910 W 14.680 Wh 0.4040 Pf 59.980 Hz E**



### 5.6.2 Data transmission stop command

Command	Size of byte	Function
'E'	1	Command
'#'	1	Closer

### 5.6.3 Watt hour control command

Command	Size of byte	Function
'W'	1	Command
'0' or, '1', or '2'	1	'0': starts the watt hour. '1': stops the watt hour. '2': resets the accumulated values from the watt hour and the watt hour time into 0. .
'#'	1	Closer

### 5.6.4 How to use

Using DP Bus, the values can be displayed as ASCII codes in the serial communication program such as HyperTerminal of Windows or minicom of Linux.

# Chapter 6 Data Logging

## 6 Data logging

### 6.1 General specifications

- 1) storage medium: EEPROM 2Mbit
- 2) Storage capacity: About 9600 sets (When storing Voltage, Current, Active power, Power factor, Electric power and Frequency)
- 3) Dynamic logging: dynamically selective logging items (Voltage, Current, Active power, Power factor, Electric power and Frequency) and logging time interval to save up to 400 days using internal memory.
- 4) Time setting mode, Run/stop mode
- 5) Multi data logging is possible.  
Finishing a logging, other loggings are possible up to 999 multi logging. When loading the multi logging, logging block will be displayed to show the multi logging. (Refer to the User's Manual for Wattman Viewer GUI Program)

If all selected	Logging interval	Total data logging time
V, A, W, Pf, Wh and Hz	1 sec.	2 hr 40 min.
V, A, W, Pf, Wh and Hz	1 min.	Around 7 days
V, A, W, Pf, Wh and Hz	30 min.	Around 210 days

< Relationship of selective items and storage time >

If some selected	Logging interval	Total data logging time
V, A and W	1 sec.	4 hr 05 min.
V, A and W	1 min.	Around 10 days
V, A and W	30 min.	Around 306 days

< Relationship of selective items and storage time >

### 6-2 Time setting mode

Time setting mode sets the time. If it reaches the set time, it is automatically finished. If you start it again after finishing, the number of logging increases (multi data logging).

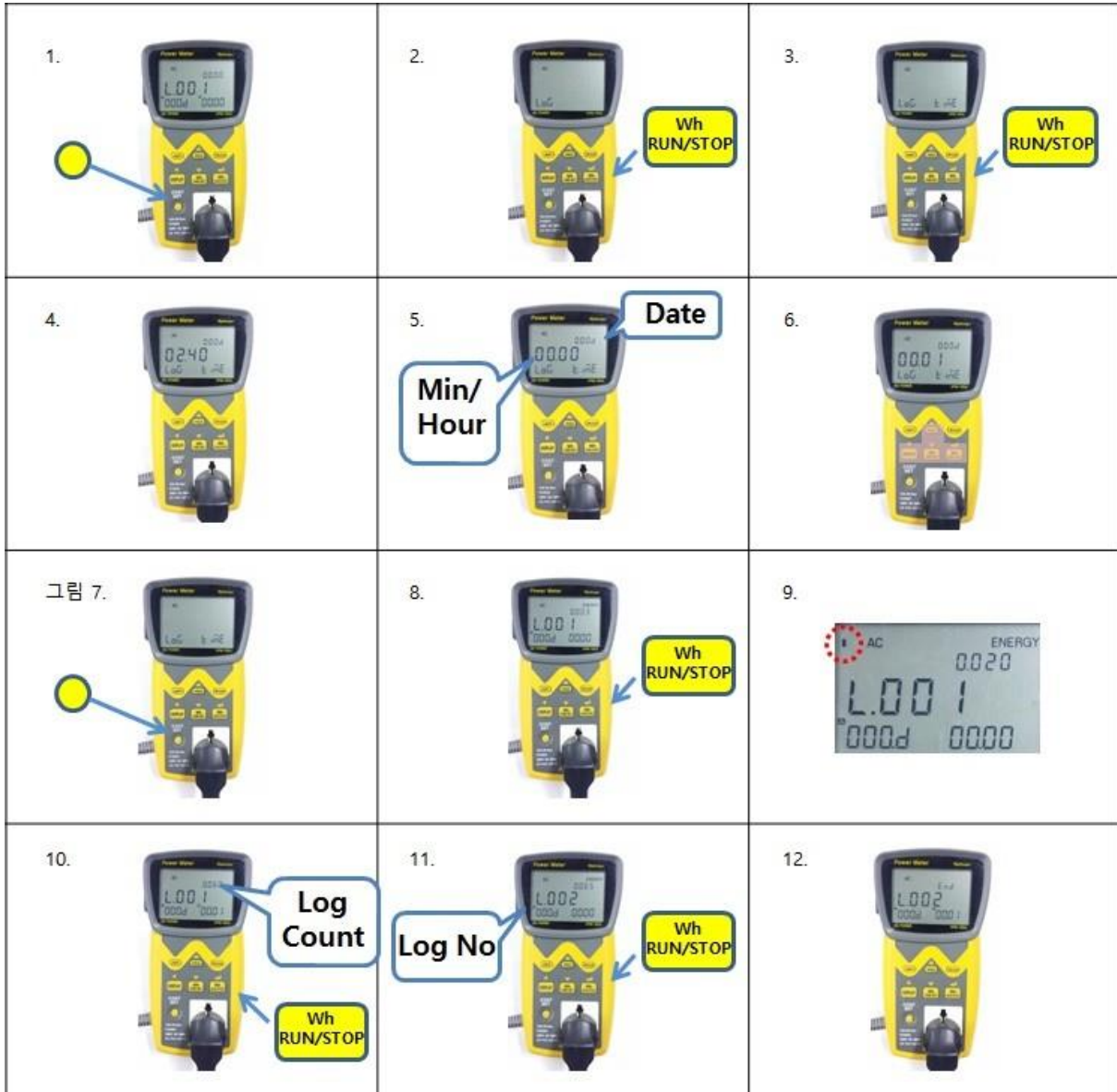

- 1) If you want to set logging time, press the COST SET button for long.
- 2) If you enter the setting mode, the Log flickers. At this time, press Wh RUN/STOP.
- 3) Time flickers. At this time, press Wh RUN/STOP.
- 4) The time you can store is indicated for about 2 seconds.

- 5) Set the time (date, hour, minute) you want to store.
- 6) HOLD(Up), Wh TIME SET(Down), DISPLAY(Move), Wh RUN/STOP(Apply)
- 7) By pressing the COST SET button, exit the setting mode.
- 8) If you press the Wh RUN/STOP button, data logging starts. If Wh is checked in the logging item at this time, the start and finish of logging is activated together with the start and finish of Wh.
- 9) If logging starts, the dot in the upper left corner of the LCD screen (inside the circle) flickers.
- 10) If the setting time is up, the End flickers in the frequency display part. If you press Wh RUN/STOP, the End stops flickering and you can check the number of data logged in the frequency display part.
- 11) If you press Wh RUN/STOP again, the number of logging increases and you can do multi data logging.
- 12) If the setting time is up, it is finished.

### 6-3 RUN/STOP mode

With '0' in the time setting, the Run/Stop mode starts and stops by the user's operation of the button. Whenever starting and stopping are repeated, the number of logging increases (multi data logging).

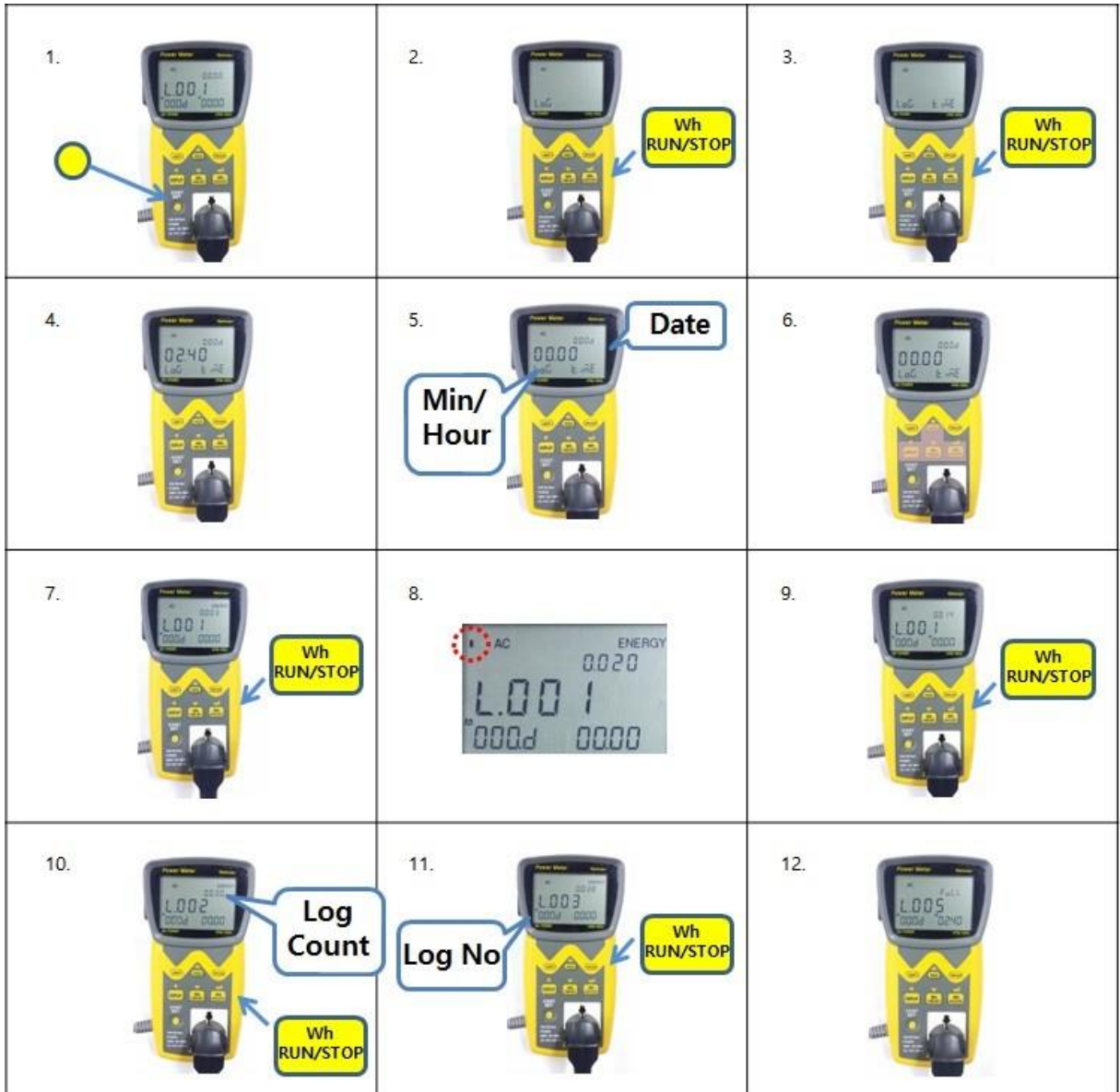

- 1) If you want to set logging time, press the COST SET button for long.
- 2) If you enter the setting mode, the Log flickers. At this time, press Wh RUN/STOP.
- 3) Time flickers. At this time, press Wh RUN/STOP.

- 4) The time you can store is indicated for about 2 seconds.
- 5) Set the time at '0'.
- 6) HOLD(Up), Wh TIME SET(Down), DISPLAY(Move), Wh RUN/STOP(Apply)
- 7) If you press the Wh RUN/STOP button, data logging starts. If Wh is checked in the logging item at this time, the start and finish of logging is activated together with the start and finish of Wh.
- 8) If logging starts, the dot in the upper left corner of the LCD screen (inside the circle) flickers.
- 9) If you press the Wh RUN/STOP button, data logging stops.
- 10) If you press the Wh RUN/STOP button again, data logging starts.
- 11) This way, you can do multi data logging repeatedly.
- 12) The biggest difference from the time setting mode is that it does not end automatically. If memory is full, it ends while FULL flickers as shown above

## 6.4 Data load



1) Run Wattman Viewer installed in PC. For installation, please refer to the user's manual of Wattman Viewer GUI Program.

2) If it is run as shown in the picture, press the Data Logging Icon on the Load Data  Data Tab. Then, Data Logging Menu appears.

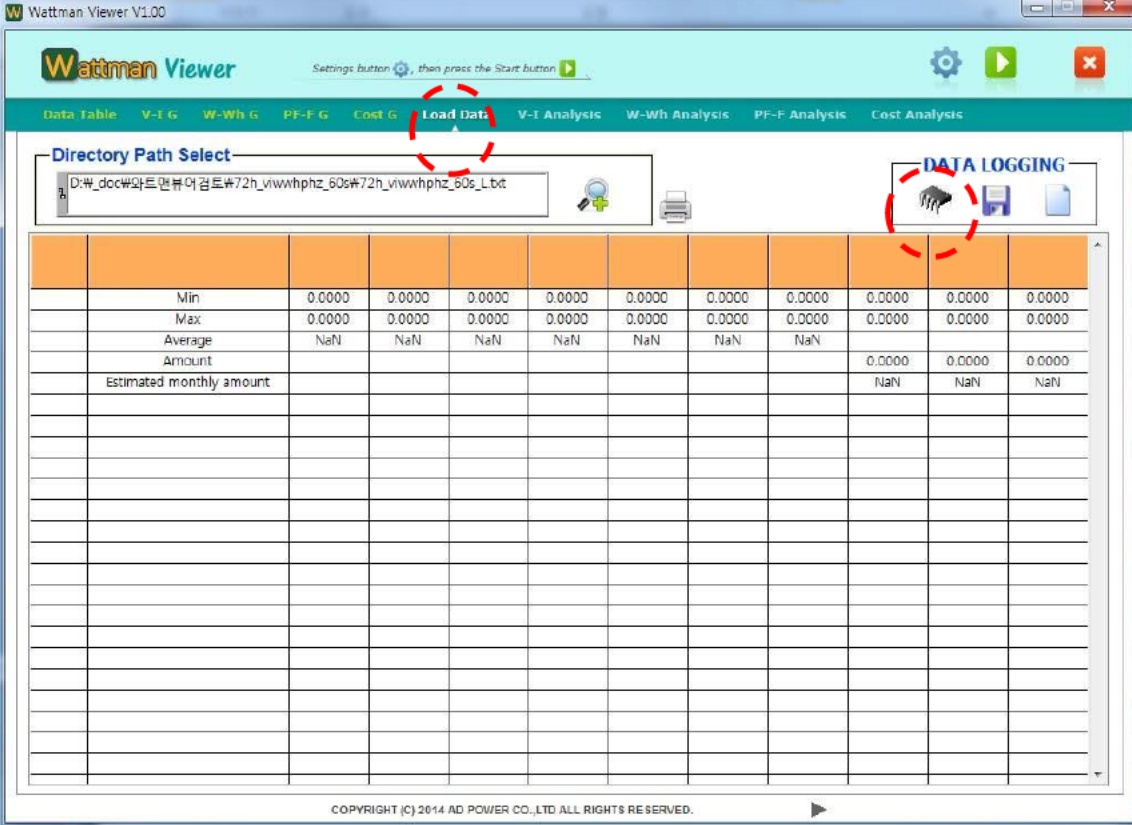
3) For more detailed information, please refer to the user's manual of Wattman Viewer GUI Program.



Wattman Viewer V1.00

**Wattman Viewer** Settings button  then press the Start button 

Data Table | V-I G | W-Wh G | PF-F G | Cost G | **Load Data** | V-I Analysis | W-Wh Analysis | PF-F Analysis | Cost Analysis

Directory Path Select

D:\#\doc#\와트맨뷰어검토#\72h\_vwwhphz\_60s#\72h\_vwwhphz\_60s\_L.txt

**DATA LOGGING** 

Min	0.0000	0.0000	0.0000	0.0000	0.0000	0.0000	0.0000	0.0000	0.0000	0.0000	0.0000
Max	0.0000	0.0000	0.0000	0.0000	0.0000	0.0000	0.0000	0.0000	0.0000	0.0000	0.0000
Average	NaN	NaN	NaN	NaN	NaN	NaN	NaN	NaN	NaN	NaN	NaN
Amount									0.0000	0.0000	0.0000
Estimated monthly amount									NaN	NaN	NaN

COPYRIGHT (C) 2014 AD POWER CO.,LTD. ALL RIGHTS RESERVED.

## Chapter 7 Maintenance

### ● How to replace a fuse

[Trouble] When power is connected, LCD is not turned on. Or while in use, LCD is suddenly turned off. In those cases, a fuse may have blown for a safety reason.  
[After sales service] <http://www.testequipmentdepot.com/>



The fuse of the electric power measuring device blows more because of loads (example, air conditioner, cleaner, motor, and heater) (The cause of the problem: bigger current or short circuit of a load) which you are going to measure than because of the measuring device itself.

If the fuse blows, find out the cause of the problem and resume measuring after solving the problem.



#### Warning

To prevent electric shock and other accidents, please read and follow the following instructions carefully.

- When the power is connected, never disassemble the equipment case.
- When the fuse has been cut off due to an overload, please replace it with a new fuse of the same rating (250V, 15A.)
- After replacing the fuse, check for the wiring before assembling the equipment cases.
- Do not open the equipment case unless you have to replace the fuse.
- We are not responsible for any problem caused by user's discretionary repair except a fuse replacement.
- Please contact our service center for other maintenances.

Test Equipment Depot - 800.517.8431 - 99 Washington Street Melrose, MA 02176

[TestEquipmentDepot.com](http://TestEquipmentDepot.com)



