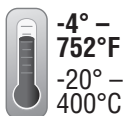

**INSTRUCTION MANUAL
INSPECTION KIT****Infrared
Thermometer**
(pg. 2)

- TARGETING LASER
- 10:1 DISTANCE-TO-SPOT RATIO
- BACKLIT DISPLAY
- AUTO POWER-OFF

**GFCI Receptacle Tester**
(pg. 7)

- FOR STANDARD AND GFCI RECEPTACLES
- DETECTS OPEN GROUND, REVERSE POLARITY, OPEN HOT, OPEN NEUTRAL, HOT/GROUND REVERSED

**CAT II
300V****Test Equipment
Depot**

1-800-517-8431

5 Commonwealth Ave
Woburn, MA 01801
Phone 781-665-1400
Toll Free 1-800-517-8431Visit us at www.TestEquipmentDepot.com**KLEIN
TOOLS**

GENERAL SPECIFICATIONS - IR1

Klein Tools IR1 is an entry-level infrared thermometer with targeting laser. It offers a wide measurement range, a 10:1 distance-to-spot ratio, a targeting laser, and user-selectable from Fahrenheit to Celsius temperature scales.

- **Environment:** Indoor or outdoor
- **Operating Altitude:** 6562 ft. (2000 m)
- **Relative Humidity:** <85% non-condensing
- **Operating Temp:** 32° to 122°F (0° to 50°C)
- **Storage Temp:** -4° to 140°F (-20° to 60°C)
- **Measurement Range:** -4° to 752°F (-20° to 400°C)
- **Units:** Settable to °F or °C
- **Emissivity:** 0.95 fixed
- **Optical Resolution (Distance-to-spot):** 10:1
- **Dimensions:** 6" x 4.1" x 1.7" (152 x 104 x 43 mm)
- **Weight:** 7.4 oz. (210 g) including battery
- **Battery Type:** 1 x 9V battery
- **Battery Life:** (Estimates assume 9V Zinc-Carbon Battery)
5 hours continuous use w/laser and backlight on.
- **Display:** Backlit LCD with white backlight
- **Display Resolution:** 0.1°F (0.1° C)
- **Laser:** FDA and IEC Class 2
- **Wavelength:** 630 – 670 nm
- **Max Power:** 1mW
- **Beam Divergence:** 1.5mrad
- **Standards:** Certified to IEC EN 61326-1:2013, EN 61326-2-3:2013, IEC EN 60825-1:2014
Complies with 21 CFR PART 1040.10 and 1040.11 except for deviation pursuant to Laser notice No.50, dated June 24, 2007
- **Pollution degree:** 2
- **Drop Protection:** 6.6 ft. (2m)

Specifications subject to change.

MEASUREMENT SPECIFICATIONS

- **Response Time:** <500ms
- **Data hold:** Yes
- **Spectral Response:** 8000-14000nm

| | |
|--------------|---|
| ≥32°F (≥0°C) | ±4°F (±2°C) or ±2%, whichever is greater |
| <32°F (<0°C) | ±(4°F + 0.1°F per degree below 32°F) ±(2.0°C + 0.1°C per degree below 0°C) |

- **Repeatability:** ±1.0% of reading or ±2°F(±1°C) (whichever is greater).
- **Temperature Correction Coefficient:** ±0.1°F per °F (±0.1°C per °C), or ±0.2% of reading (whichever is greater) when ambient temperature is above or below 70 – 77°F (21 – 25°C).

Specifications subject to change.

WARNINGS

To ensure safe operation and service of the tester, follow these instructions. Failure to observe these warnings can result in severe injury or death. Retain these instructions for future reference.

**WARNING: LASER RADIATION. DO NOT STARE INTO BEAM.
Class II Laser.**

- Exposing eyes to laser radiation can result in severe and permanent eye injuries. NEVER look directly into the laser beam emitted by this instrument.
- DO NOT use the instrument if the case is damaged in any way.
- DO NOT modify the instrument in any way, as to do so could result in emission of hazardous laser radiation than could result in severe and permanent eye injuries.
- DO NOT use optical equipment such as lenses, prisms, optical scopes, etc. to transmit, retransmit, or view the laser beam as this could result in severe and permanent eye injuries.
- This product should not be used in any location that could result in somebody looking at or having their eyes inadvertently irradiated by the laser beam as this could result in severe and permanent eye injuries.
- This product should not be used by untrained operators or operators who have not read and fully understood the instructions.
- Thermometer is NOT intended for use on people or animals.
- DO NOT remove warning labels from this instrument as this could result in serious personal injury and increases the risk of exposure to hazardous laser irradiation.
- Discontinue using the instrument immediately if it is acting abnormally.
- Be cautious of infrared temperature measurements of reflective materials as the instrument may indicate that these surfaces are cooler than their actual temperature (see Emissivity section).
- There are no user serviceable parts in this instrument.

SAFE PRACTICES

This meter is designed for professionals who understand the hazards associated with their trade. While this meter causes no foreseeable dangers beyond its targeting laser, the objects being measured, as well as the environment in which they reside, can be hazardous. Common safety practices to follow when operating near temperature critical environments are:

- Before using this meter, determine if an area is safe, verify correct operation by measuring a known temperature value of a comparable object.

Warning label on side of thermometer

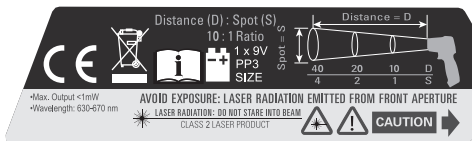

FEATURE DETAILS

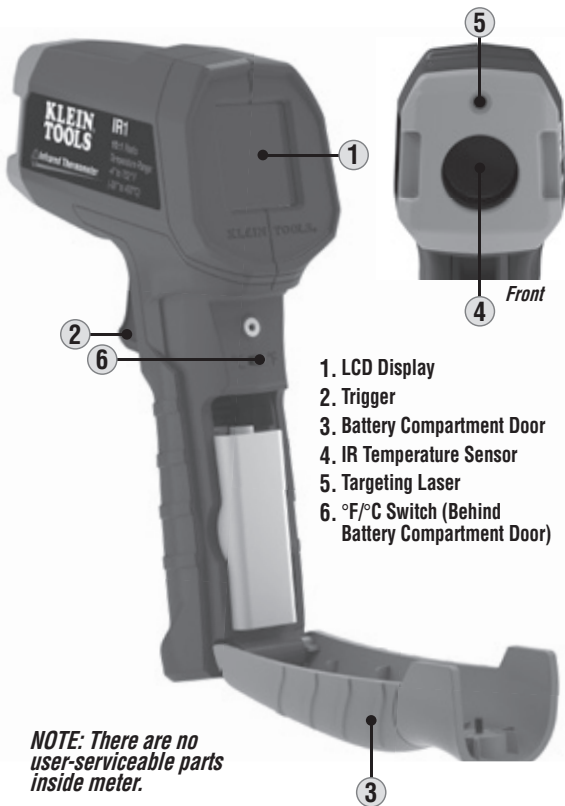

- 1. LCD Display
- 2. Trigger
- 3. Battery Compartment Door
- 4. IR Temperature Sensor
- 5. Targeting Laser
- 6. °F/°C Switch (Behind Battery Compartment Door)

NOTE: There are no user-serviceable parts inside meter.

SYMBOLS ON LCD

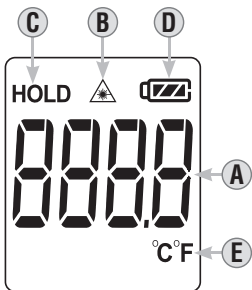

- A. Temperature Reading
- B. Targeting laser active
- C. Data Hold
- D. Battery level indicator
- E. Active temperature scale

OPERATING INSTRUCTIONS

TEMPERATURE MEASUREMENT

To measure temperature with the IR1, aim the meter at the object to be measured, pull the trigger ② and hold it depressed for at least 2 seconds. Releasing the trigger initiates Data Hold, "HOLD" will show on the display, and the measurement will be held on the display. If the display shows "OL" or "-OL" following a measurement, this indicates that the surface temperature of the object being measured is either above or below the measurement range of the meter.

TARGETING

The IR1 features a laser ⑤ to assist in targeting the measurement area. Measurement areas located far away from the meter will be larger than those close to the meter.

The meter is configured with 10:1 optical resolution (distance-to-spot ratio). The distance-to-spot ratio defines the size of the measurement area relative to the distance between the measurement location and the IR sensor ④. Typical diameters of the measurement area as a function of the distance between the meter and the target area are depicted below for 10:1 optical systems (FIG. 1).

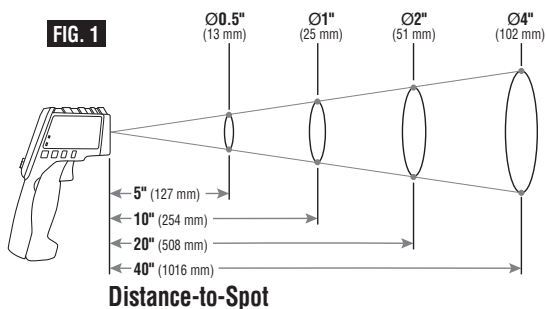

NOTE: Increased distance from target may affect reading accuracy.

TARGETING LASER

The laser is on when the trigger ② is held, and is off when released. When on, the laser icon "  " will be visible on the display.

SELECTING A TEMPERATURE SCALE

The default scale is Fahrenheit (°F). To change, loosen the screw in the Battery Compartment Door ③ and push the °F/°C Switch ⑥ to change to Celsius (°C). Replace the Battery Compartment Door ③ and tighten screw to secure, taking care not to over-tighten.

MAINTENANCE

BATTERY REPLACEMENT

When  indicator is displayed on LCD, battery must be replaced.

1. Loosen the screw in the Battery Compartment Door **3** to open.
2. Remove exhausted 9V battery and dispose of appropriately.
3. Replace 9V battery and return Battery Compartment Door **3** and tighten screw to secure, taking care not to over-tighten.

CLEANING

Be sure meter is turned off and wipe with a clean, dry lint-free cloth. **Do not use abrasive cleaners or solvents.** Take care to keep the sensor lens clean at all times. If required, loose debris may be removed from lens using clean compressed air. Lens may also be cleaned using a soft cloth or cotton swab with water or rubbing alcohol **only**. Lens must be allowed to completely dry prior to use.

STORAGE

Remove the battery when meter is not in use for a prolonged period of time. Do not expose to high temperatures or humidity. After a period of storage in extreme conditions exceeding the limits mentioned in the General Specifications section, allow the meter to return to normal operating conditions before using.

GENERAL SPECIFICATIONS - RT210

Relative Humidity: < 85% non-condensing

Operating Temperature: 32° to 140°F (0° to 40°C)

Storage Temperature: 14° to 122°F (-10°C to 50°C)

Operating Altitude: Up to 6562 ft. (2000 m)

Weight: 1.2 oz. (33 g)

Nominal Voltage: 110 - 125V AC at 50/60Hz in 3-wire outlet

Mains Supply Voltage Fluctuations: ±10%

Pollution Degree: 2

Nominal Power: 0.3W

Standards: Conforms To UL Std 61010-1, 61010-2-030,1436

Certified To CSA Std C22.2 #61010-1, 61010-2-030,160



Intertek
5001748

Drop Protection: 6.6 ft. (2 m)

Safety Rating: CAT II 300V

⚠️ WARNINGS

Read, understand, and follow all warnings and instructions before operating testers. Failure to follow instructions could result in death or serious injury. Before each use, verify tester operation by testing on a known live and correctly wired receptacle. Do not use if the tester appears damaged in any way. The tester is intended for indoor use only. Other equipment or devices attached to the circuit being tested could interfere with the tester, clear the circuit before testing. This tester only detects common wiring problems. Always consult a qualified electrician to resolve wiring problems.

FIG. 2



Indicator Illuminated



Indicator Not Illuminated

| INDICATOR | | FAULT | EXPLANATION |
|-----------|--|----------------------|--|
| | | Open Ground | Ground contact is not connected |
| | | Open Neutral | Neutral contact is not connected |
| | | Open Hot | Hot contact is not connected |
| | | Hot/Ground Reversed | Hot and ground connections are reversed |
| | | Hot/Neutral Reversed | Hot and neutral connections are reversed |
| | | Correct | Receptacle is wired correctly |

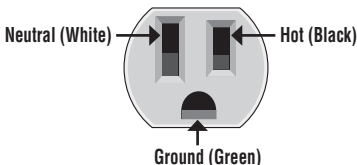

OPERATING INSTRUCTIONS

WIRING CONFIGURATION TESTING

Conditions indicated: wiring correct, open ground, reverse polarity, open hot, open neutral and hot/ground reversed.

Conditions NOT indicated: quality of ground, multiple hot wires, combinations of defects, reversal of grounded and grounding conductors.

All appliances or equipment on the circuit being tested should be unplugged to help reduce the possibility of erroneous readings.

STANDARD RECEPTACLES

1. Verify tester operation by testing on a known live and correctly wired receptacle.
2. Plug tester into receptacle.
3. Compare the illuminated lights on the tester to the key code printed on the tester.
4. If the tester indicates that the receptacle is not wired correctly, consult a qualified electrician.

GFCI RECEPTACLES

1. Check the GFCI receptacle user manual for information on how the specific receptacle operates prior to using this tester.
2. Insert the tester into the receptacle under test to check for correct wiring (See **FIG. 2**). Lights on the tester should illuminate.
3. Press the "TEST" button on the GFCI receptacle. ***Did the GFCI trip and the lights on the tester go dark?***

YES: Reset the GFCI by pressing the reset button. Proceed to step 4.

NO: The GFCI is not operating properly or the receptacle is miswired. Consult a qualified electrician.

4. Press and hold the test button on the tester for 7 seconds. ***Did the GFCI trip and the lights on the tester go dark?***

YES: Reset the GFCI by pressing the reset button. The GFCI appears to be operating properly.

NO: The GFCI is not operating properly or the receptacle is miswired. Consult a qualified electrician.

CLEANING

Be sure meter is turned off and wipe with a clean, dry lint-free cloth. ***Do not use abrasive cleaners or solvents.***