

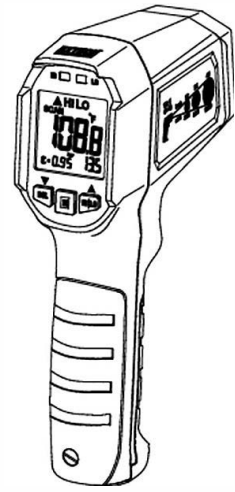

User Manual



Extech Model IR320

Waterproof, Dual Laser IR Thermometer with Alarm

1. Introduction

Thank you for selecting the Extech IR320 IR Thermometer. The IR320 is a professional non-contact infrared thermometer that measures surface temperature from infrared energy radiated by the target's surface. We ship this meter fully tested and calibrated and, with proper use, it will provide years of reliable service. Please visit our website (www.extech.com) for the latest version of this User Manual and Customer Support.

2. Product Features

Strong and Durable: 3m (9.8 ft.) drop-proof

Dustproof and Waterproof: IP65

Ergonomic Design: Comfortable handheld, simple and convenient operation

MAX/MIN/AVG/DIF values: Quickly display the Maximum, Minimum, Average (running average updates every two readings), and Differential (Max minus Min) values

Large Backlit LCD

Tripod mount for hands-free operation

Alarm Function: High/Low temperature alarm provides flashing color-coded LED indicators when triggered

Dual Laser Pointers: To enhance measurement target accuracy

3. Safety Instructions



WARNING

To avoid personal injury, please read the following safety information before using this product:

- Safety Standards Compliance:
CE Identification: EN 61326-1: 2013, EN 61326-2-3: 2013
Laser Safety Standard: Complies with 21 CFR 1040.10 and 1040.11 except for deviations pursuant to laser notice no. 50 dated June 24, 2007
- Please do not point the laser toward people or animals directly or indirectly.
- Please do not look at the laser directly or through other optical tools (telescope, microscope, etc.).
- If the battery symbol on the LCD display is flashing, replace the batteries immediately to avoid inaccurate measurements.
- Before using the product, check the product for damage. Do not use this product if obvious physical damage is apparent.
- Refer to the *Table of Emissivity Factors for Common Materials* in this manual before taking measurements. Reflective objects will cause the measured value to be lower than the actual temperature value. Set the emissivity to match each given surface type. When measuring, please do not touch high temperature surfaces.
- Do not use this product near explosive gases.
- To ensure measurement accuracy, place this product in the test environment for more than 30 minutes before use.
- Avoid keeping the thermometer near high temperature objects for long periods.

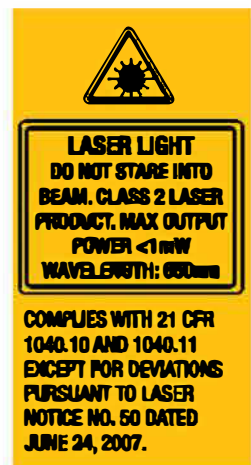

4. Product Description

Meter Description

1. Low Alarm Alert (blue indicator)
2. High Alarm Alert (red indicator)
3. Backlit LCD
4. RCL (Recall MIN-MAX-AVG-DIF) and down arrow button
5. M (Mode) button
6. Battery compartment
7. Battery compartment screw
8. HI-LO (alarm) and up arrow button
9. Laser pointer lenses
10. IR measurement lens
11. Measurement trigger
12. Tripod mount

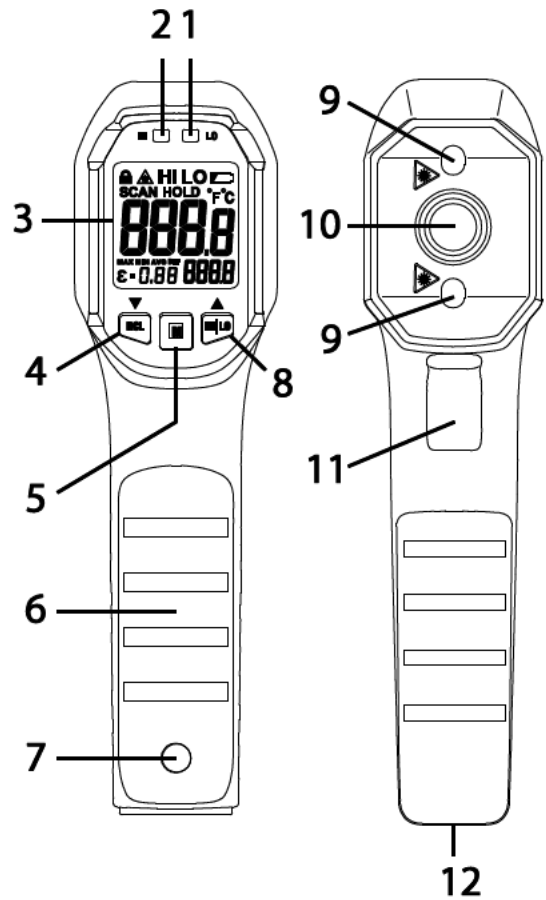

Display Description

	Automatic measurement mode	
	Laser set to default ON	
HI LO	High/Low Alarm modes	
	Low battery	
SCAN	Scan mode (trigger pulled)	
HOLD	Measurement Data Hold	
°C	Units of measure for temperature	
8888	Primary measurement digits (center)	
MAX MIN AVG DIF	Maximum, Minimum, Average, Differential values	
ε = 0.88	Emissivity setting	
8888	Secondary digits for MAX/MIN/AVG/DIF values (lower right)	

5. Operation



Power On and Off

Pull the trigger to power the meter, the LCD (and backlight) will turn on. The thermometer will power off automatically after approximately eight (8) seconds.

Manual Measurements

1. Pull and hold the trigger after aiming toward the target to measure.
2. The **SCAN** icon will flash while measuring the targeted surface or object. The center of the measurement spot is equidistant between the two laser points (enable/disable lasers per the *Lasers Enable/Disable* section).
3. Read the temperature measurement on the large digits at the center of the LCD.
4. Release the trigger. The **SCAN** icon disappears and the **HOLD** icon appears, indicating that the measurement has stopped and the display is holding the last measured value. The meter will power off automatically after approximately eight (8) seconds.

Automatic Measurements (trigger-free)

1. Pull and release the trigger to power the meter.
2. Press the **M** button six (6) times; the  will appear on the upper left.
3. Use the arrow buttons to turn the mode ON (or OFF).
4. Pull and release the trigger. The  icon will remain ON and the **SCAN** icon will flash. The thermometer will continuously measure the target temperature (without having to hold the trigger). Note that In Auto mode, the LCD backlight will switch off after 2 minutes.

CAUTION: If you enable the lasers (see *Lasers Enable/Disable*), they will remain ON during the measurement scan.

5. To stop the measurement, pull and release the trigger again. The Auto measure icon  and the **SCAN** icon will disappear, and the **HOLD** icon will appear. The meter will stop measuring and will hold the last measured value on the LCD until it automatically switches off after approximately eight (8) seconds.

MAX/MIN/AVG/DIF Values

With the meter ON, short press the **RCL (Recall)** button to step through the MAX/MIN/AVG/DIF modes respectively; the display will show the value of the corresponding mode in the secondary display area (lower right). The **MAX** value is the highest reading taken in a given measurement session, the **MIN** value is the lowest reading, the **AVG** value is a running average that updates every two readings, and the differential (**DIF**) is the MAX minus MIN value.

Alarm Activation

With the meter ON, short press the **HI/LO** button to select the HI-LO alarm mode, HI-only alarm mode, LO-only alarm mode, or no alarm mode (the display icons will inform as to what mode is currently selected: **HI**, **LO**, **HI-LO**, or no icons). When you select the HI alarm mode, the **HI** LED will flash red when the measured temperature exceeds the high alarm limit. When you select the LO alarm mode, the **LO** LED will flash blue when the measured temperature is lower than the low alarm limit. When you select the HI-LO alarm mode, the **HI** or **LO** LED will flash depending on whether the measured temperature is higher than the HI limit or lower than the LO limit.

HIGH and LOW Alarm Limit Setting

With the meter ON, short press the **M** button once to access the HI alarm screen or press **M** twice to step to the LO alarm screen. Use the up/down buttons to set the alarm thresholds. Short press the up/down buttons to add or subtract 1 unit, long press to change the units rapidly. The meter will exit the setup screen automatically after five (5) seconds of button inactivity.

Emissivity Setting

With the meter ON, short press the **M** button three (3) times to step to the emissivity screen. Use the up/down buttons to set the desired value (from 0.10 ~ 1.00). Short press the up or down button to add or subtract 0.01 units or long press to change the units rapidly. The meter will exit the setup mode after five (5) seconds of button inactivity. For more, see the *Emissivity Considerations* section.

Unit of Measure Setup

With the meter ON, short press the **M** button four (4) times to step to the unit of measure screen. Use the up/down buttons to change the units (°C or °F). The meter will exit the setup mode after five (5) seconds of button inactivity.

Lasers Enable/Disable

With the meter ON, short press the **M** button five (5) times to step to the laser screen. Use the up/down buttons to select ON/OFF. The laser icon  appears on the LCD when you enable the lasers, indicating that the laser will light when you pull the trigger (or remain ON in Automatic Measurement mode). The meter will exit the setup mode automatically after five (5) seconds of button inactivity.

6. IR Measurement Considerations

1. To detect a **hot or cold spot**, aim the IR thermometer at a region beyond the target and then scan the entire region in a slow, up/down motion.

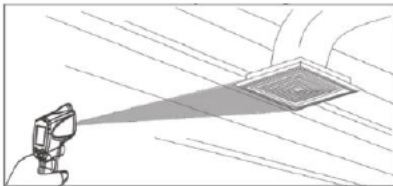

2. **Distance-to-Spot (D:S) ratio.** The meter's field of view is 12:1. For example, if the **distance** from the meter to the target is 12 inches, then the **diameter** of the target will be 1 inch. See diagram below.

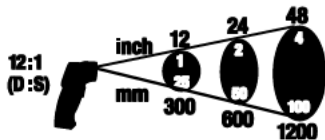

3. Make measurements < 2 feet from the target when possible. The meter can measure from further distances but **external sources of light can affect measurements**. In addition, the spot size may be so large that it encompasses unwanted surface targets.

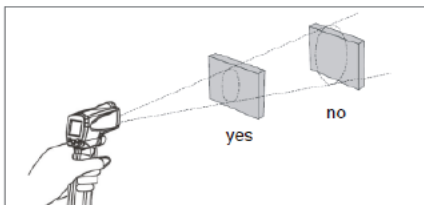

4. If frost, oil, grime, etc., covers the surface of the object under test, please clean before taking measurements.
5. If an object's surface is reflective, apply masking tape or flat black paint to the surface before measuring.
6. The meter cannot make accurate measurements through transparent surfaces such as glass.
7. Steam, dust, smoke, etc. can obscure measurements.
8. The meter compensates for deviations in ambient temperature. It can take up to 30 minutes however for the meter to adjust to wide ambient temperature changes.

7. Emissivity Considerations

The Emissivity setting is shown in small digits at the lower left corner of the display. To adjust the Emissivity please refer to the Emissivity Setting section. Emissivity represents the reflectivity of a material. Most organic materials and painted or oxidized surfaces have an emissivity of approximately 0.95. Masking tape or flat black paint should be applied to cover the measured surface. Wait a period of time to allow the tape or paint to reach thermal equilibrium with the surface of the covered object. Measure the temperature of the surface covered with tape or paint only after equilibrium has been achieved.

Table of Emissivity Factors for Common Materials

Measured Surfaces	Emissivity	Measured Surfaces	Emissivity
Metals		Non-Metals	
Aluminum Oxidization	0.2-0.4	Asbestos	0.95
A3003 Alloy Oxidization Rough	0.3 0.1-0.3	Asphalt	0.95
Brass Burnishing Oxidization	0.3 0.5	Basalt	0.7
Copper Oxidization Electric Terminal Board	0.4-0.8 0.6	Carbon Non-Oxidization Graphite Silicon Carbide	0.8-0.9 0.7-0.8 0.9
Hastelloy Alloy	0.3-0.8	Ceramics	0.95
Inconel Oxidization Sand-Blasting Electro Burnishing	0.7-0.95 0.3-0.6 0.15	Clay	0.95
Iron Oxidization Rusting	0.5-0.9 0.5-0.7	Concrete	0.95
Iron (Casting) Oxidization Non-Oxidization Casting	0.6-0.95 0.2 0.2-0.3	Cloth	0.9
Iron (Forging) Passivation	0.9	Glass Convex Glass Smooth Glass Lead-Boron Glass	0.76-0.8 0.92-0.94 0.78-0.82
Lead Rough Oxidization	0.4 0.2-0.6	Plates	0.96
Molybdenum Oxidization	0.2-0.6	Stone Products	0.93
Nickel Oxidization	0.2-0.5	Plaster	0.8-0.95
Platinum Black	0.9	Ice	0.98
Steel Cold rolling Steel Plate Burnishing Steel Plate Rubbing	0.7-0.9 0.4-0.6 0.1	Limestone	0.98
Zinc Oxidization	0.1	Paper	0.95
		Plastics	0.95
		Water	0.93
		Soil	0.9-0.98
		Wood	0.9-0.95

8. Maintenance

Cleaning

To clean the lenses, use compressed air to clear dust and other particles, then carefully clean with a wet cotton swab, moistened with clean water. To clean the meter housing, wipe with a soft, damp cloth. Do not use solvents or abrasives. Do not immerse the meter in liquid.

Battery Installation and Replacement

Install or replace the 9V battery according to the following figure.

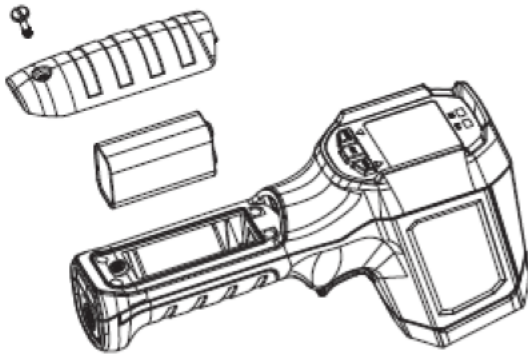

Never dispose of used batteries or rechargeable batteries in household waste.

As consumers, users are legally required to take used batteries to appropriate collection sites, the retail store where the batteries were purchased, or wherever batteries are sold.

Disposal: Do not dispose of this instrument in household waste. The user is obligated to take end-of-life devices to a designated collection point for the disposal of electrical and electronic equipment.

9. Specifications

Measurement Range	-20°C~650 °C (-4°F ~1202 °F)
Accuracy	≥0 °C: ±1.8 °C or ±1.8% of reading, whichever is greater < 0 °C: ±(1.8 °C +0.1 °C / °C)
	≥32 °F: ±3.6 °F or ±1.8% of reading, whichever is greater < 32 °F: ±(3.6 °F +0.1 °F / °F)
Temperature Coefficient	0.1 °C / °C (0.1 °F / °F) or ±0.1% of reading per degree, whichever is greater
D:S Ratio	12:1 distance-to-spot ratio
Emissivity	0.1~1.0 adjustable
Response Time	250ms (95% of reading)
Spectral Response	8um~14um
Display Resolution	0.1 °C (0.1 °F)
Repeatability	±1.0 °C (1.8 °F) or 0.8% of reading, whichever greater.
Laser configuration	Dual Laser
Laser Type	CLASS II
Laser Wavelength	630nm~670nm
Laser Power	<1mW
Battery Type	9V Battery (6F22), included
Battery Life	≥6h (operating continuously with backlight on)
Dimensions	189mm*118mm*55mm (7.4*4.6*2.2 in.)
Weight	292g (10.3 oz.)
Operating Temperature	0 °C ~50 °C (32 °F ~104 °F)
Storage Temperature	-20 °C ~60 °C (-4 °F ~140 °F)
Operating Humidity	< 90% RH (non-condensing)
Operating Altitude	2000m (6562 ft.)
Storage Altitude	12000m (39,370 ft.)
Water Protection Level	According to IEC60529, complies with IP65
Drop Test	3m (9.8 ft.)

Safety Standards Compliance

CE Identification: EN 61326-1: 2013, EN 61326-2-3: 2013

Laser Safety Standard: Complies with 21 CFR 1040.10 and 1040.11 except for deviations pursuant to laser notice no. 50 dated June 24, 2007