

# IRT225

## 10:1 Mini IR Thermometer



### ***Introduction***

---

Congratulations on your purchase of the IRT225 10:1 infrared thermometer. The IRT225 can quickly and accurately determine the surface temperature by measuring the infrared energy radiated from the target surface. It is suitable for non-contact surface temperature measurements.

## Safety

---



**Warning:**



**LASER RADIATION DO NOT STARE INTO BEAM**



OUTPUT < 1mW COMPLIES WITH EN60825-1:2014

To avoid eyes or personal injury, please read the following safety instructions before using the thermometer:

- Please do not irradiate people or animals with laser directly or indirectly.
- Please do not look at the laser directly or through other optical tools (telescope, microscope, etc).
- If battery symbol on LCD display is flashing, replace batteries immediately to avoid inaccurate measurements before using the thermometer.
- Inspect the case before using the thermometer. Do not use the thermometer if it appears damaged. Look for cracks or missing plastic.
- Please refer to the emissivity information for the actual temperature. Reflective objects can cause the actual temperature value to be higher than the measured temperature value. When measuring these objects, please be aware not to touch high temperature surfaces.
- Do not use the thermometer in an explosive gas, steam, or humid environment.
- To ensure measurement accuracy, place the thermometer in the current environment for more than 30 minutes before using it.
- Avoid keeping the thermometer near high temperature objects for a long time

# Description

## METER DESCRIPTION

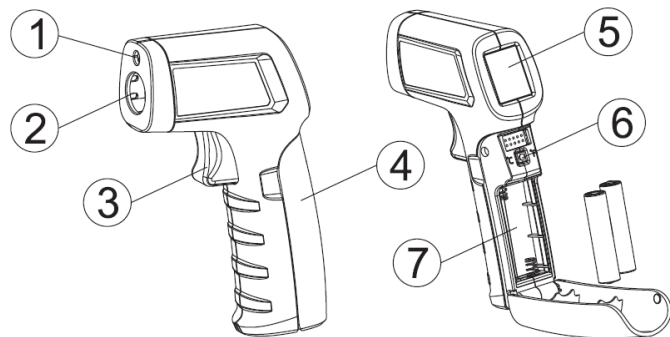

1	Laser	2	Infrared sensor
3	Trigger	4	Battery cover
5	LCD	6	°C/°F switching button
7	Battery compartment		

## LCD DESCRIPTION

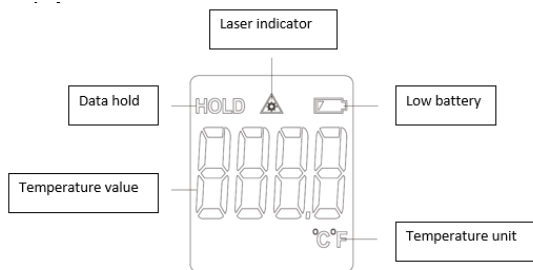

### 1. Function Indicators

# Operation

## Viewing the Last Measured Value

In the off state, short press the trigger to turn on the thermometer, it will display the last measurement data that was held before the last shutdown.

## Temperature Measurement

Aim the thermometer at the target, then pull and hold the trigger, the laser indicator on the LCD display shows that the laser is turned on and points to the target, the measured temperature value will be displayed on the LCD, and the maximum or minimum temperature of the target area can be measured by scanning up, down, left and right according to the laser spot indication.

Note: The measurement distance must be determined by the size of the measured target according to the "distance to spot size ratio (D:S)" and "field of view".

## Hold

After the trigger is released, the last measured value and the HOLD icon will remain on the LCD display. If there is no operation for 8 seconds, the thermometer will automatically shut down and save the last measured value.

## Unit Conversion

In the power-on state, open the battery cover and short press the °C/°F button to switch the temperature unit to Celsius (°C) or Fahrenheit (°F).

## Distance to Spot Size Ratio (D:S)

As the distance (D) from the target being measured increases, the spot size (S) on the measured area becomes larger. The relationship between the distance and the spot diameter is as shown in the figure below.

The spot diameter represents 90% of the energy in the circle. The maximum D:S (10:1) will be obtained when the thermometer is 400mm (16") from the target resulting in a spot diameter of 40mm (1.6").

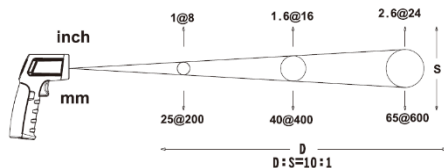

## Field of View

Make sure that the measured target is larger than the spot diameter. The smaller the target is, the closer the test distance should be (please refer to D:S for the spot diameter at different distances). To obtain the best measurement result, it is recommended that the target being measured is 2.5 times larger than the spot diameter.

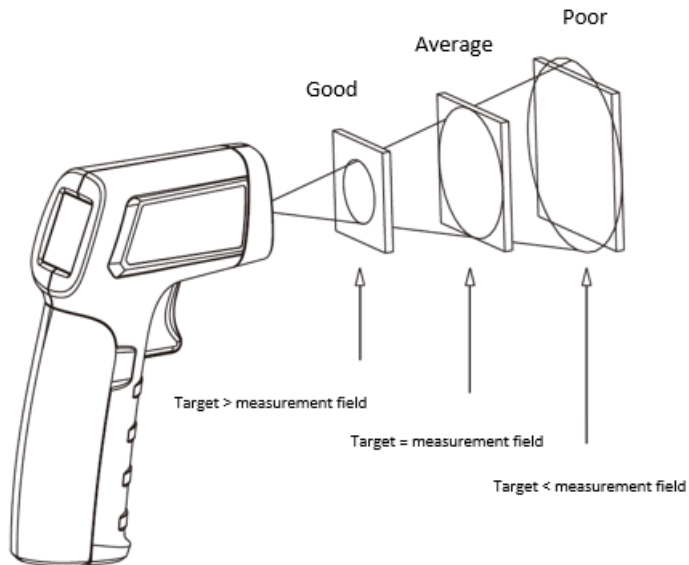

## ***Troubleshooting***

Symptom	Problem	Action
OL appears when measuring	Measured value is greater than the maximum range	Stop measuring
-OL appears when measuring	Measured value is less than the minimum range	Stop measuring
Err appears when booting	Exceeding the minimum or maximum operating ambient temperature	Place the thermometer in a 0°C~50°C (32°F~122°F) environment, and it can be recovered after 30 minutes
Battery indicator flashes	Low battery	Replace batteries
Laser fails to work / weak laser	Low battery	Replace batteries

The measurement is inaccurate	Low battery, emissivity mismatching, measured distance is too far, measured target diameter is less than 20mm, etc.	Please refer to the instructions for field of view, D:S, etc.
-------------------------------	---	---

## ***Maintenance***

### **Cleaning and storage**

1. The meter should be wiped with a damp cloth and mild detergent when necessary. Do not use solvents or abrasives.
2. Store the meter in an area with moderate temperature and humidity.

### **Battery Replacement**

Please install or replace the batteries (AAA (LR03) 2\*1.5V) as shown on the right.

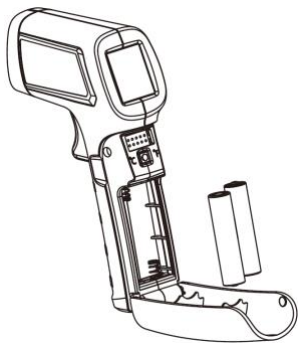

## Specifications

Temperature range	-20°C~400°C (-4°F~752°F)
Accuracy Ambient temperature 21°C~25°C (70°F~77°F)	>0°C: $\pm 2.0^{\circ}\text{C}$ or $\pm 2\%$ of reading, whichever is greater $\leq 0^{\circ}\text{C}$ : $\pm(2.0^{\circ}\text{C}+0.1^{\circ}\text{C}/^{\circ}\text{C})$ >32°F: $\pm 4.0^{\circ}\text{F}$ or $\pm 2\%$ of reading, whichever is greater $\leq 32^{\circ}\text{F}$ : $\pm(4.0^{\circ}\text{F}+0.1^{\circ}\text{F}/^{\circ}\text{F})$
Temperature coefficient	$\pm 0.1^{\circ}\text{C}/^{\circ}\text{C}$ or $\pm 0.1\%/^{\circ}\text{C}$ , whichever is greater ( $\pm 0.1^{\circ}\text{F}/^{\circ}\text{F}$ or $\pm 0.1\%/^{\circ}\text{F}$ , whichever is greater)
D:S ratio	10:1 (calculated at 90% energy)
Emissivity	0.95
Response time	$\leq 500\text{ms}$
Spectral response	5.5 $\mu\text{m}$ ~14 $\mu\text{m}$
Resolution	0.1°C (0.1°F)
Repeatability	1°C or 1.0%, whichever is greater (2°F or 1.0%, whichever is greater)
Laser	Single laser, wavelength 630nm~670nm Output power < 1mW, class 2 laser
Battery type	AAA * 2   1.5V
Battery life	$\geq 20\text{H}$ (continuous operation when laser backlight is turned on)
Product size	135mm*94mm*36mm
Product weight	About 148g (including batteries)
Operating temperature	0°C~50°C (32°F~104°F)
Storage temperature	-20°C~60°C (-4°F~140°F)
Operating humidity	<RH90% (non-condensing)
Drop test	1m



## **Safety Standards**

CE Certification: EN61326-2-3: 2013

Laser safety standard: EN60825-1:2014

## **Reference Standard**

JJG 856-2015

## ***Warranty***

---

Triplett / Jewell Instruments extends the following warranty to the original purchaser of these goods for use. Triplett warrants to the original purchaser for use that the products sold by it will be free from defects in workmanship and material for a period of (1) one year from the date of purchase. This warranty does not apply to any of our products which have been repaired or altered by unauthorized persons in any way or purchased from unauthorized distributors so as, in our sole judgment, to injure their stability or reliability, or which have been subject to misuse, abuse, misapplication, negligence, accident or which have had the serial numbers altered, defaced, or removed.

Accessories, including batteries are not covered by this warranty

**Copyright © 2021 Triplett**