



DATA SHEET

CP 110



Differential pressure transmitter



Ranges from -100/+100 Pa to -2000/+2000 mbar (according to model)



Configurable intermediary ranges

- 0-10 V or 4-20 mA output, active, power supply 24 Vac/Vdc (3-4 wires) or 4-20 mA output, passive loop, power supply from 16 to 30 Vdc (2 wires)
- ABS V0 housing, IP65, with or without display
- "¼ turn" system mounting with wall-mount plate
- Housing with simplified mounting system
- Solenoid valve for auto-calibration (only on CP 111 model)

Part number

CP 11 —
 3 —
 A —
 O

Measuring range

1: -100/+100 Pa
 2: -1000/+1000 Pa
3: -10,000/+10,000 Pa
 4: -500/+500 mbar
 5: -2000/+2000 mbar

Power supply / Output

A: Active – 24 Vac/Vdc – 0-10 V or 4-20 mA
P: Passive – 16/30 Vdc – 4-20 mA
 (except the CP 111 which is not available in Passive).

Display

O: With display
N: Without display

Example: CP 113 – AO
 Pressure transmitter measuring range -10,000/+10,000 Pa, 0-10 V or 4-20 mA active, with display

	CP 111	CP 112	CP 113	CP 114	CP 115
Measuring ranges	-100/+100 Pa	-1000/+1000 Pa	-10,000/+10,000 Pa	-500/+500 mbar	-2000/+2000 mbar
Measurement units	Pa, mmH ₂ O, inWG, mmHG, daPa, kPa, hPa, mbar	Pa, mmH ₂ O, inWG, mmHG, daPa, kPa, hPa, mbar	Pa, mmH ₂ O, inWG, mmHG, daPa, kPa, hPa, mbar	mbar, inWG, mmHG, PSI, mmH ₂ O, daPa, hPa, kPa	mbar, inWG, mmHG, PSI, mmH ₂ O, daPa, hPa, kPa
Accuracy*	±1% of reading ±2 Pa	±1.5% of reading ±3 Pa	±1.5% of reading ±30 Pa	±1.5% of reading ±3 mbar	±1.5% of reading ±3 mbar
Resolution	1 Pa; 0.1 mmH ₂ O; 0.01 mbar; 0.01 inWG; 0.01 mmHG; 0.1 daPa; 0.001 kPa; 0.01 hPa	1 Pa; 0.1 mmH ₂ O; 0.01 mbar; 0.01 inWG; 0.01 mmHG; 0.1 daPa; 0.001 kPa; 0.01 hPa	1 Pa; 0.1 mmH ₂ O; 0.01 mbar; 0.01 inWG; 0.01 mmHG; 0.1 daPa; 0.01 kPa; 0.01 hPa	1 mbar; 0.1 inWG; 1 mmHG; 1 mmH ₂ O; 1 hPa; 10 daPa; 0.1 kPa; 0.1 PSI	1 mbar; 0.1 inWG; 1 mmHG; 1 mmH ₂ O; 1 hPa; 10 daPa; 0.1 kPa; 0.1 PSI
Overpressure tolerated	21 000 Pa	21 000 Pa	69 000 Pa	1400 mbar	4100 mbar

General features

Response time	1/e (63%) 0.3 s
Zero setting	Manual autozero with push-button. Self-calibration by solenoid valve (CP 111 only)
Type of fluid	Air and neutral gases
Conditions of use (°C/%RH/m)	From 0 to +50°C. In non-condensing condition. From 0 to 2000 m
Storage temperature	From -10 to +70 °C

Features of the housing

Material	ABS V0 as per UL94
Protection	IP65
Display	LCD 10 digits. Dimensions: 50 x 17 mm. Height of digits: Values: 10 mm; Units: 5 mm
Connections	Ribbed, Ø 6.2 mm
Cable gland	For cables Ø 8 mm maximum
Weight	143 g

*All the accuracies indicated in this technical datasheet were stated in laboratory conditions, and can be guaranteed for measurements carried out in the same conditions, or carried out with calibration compensation.

Technical specifications

Output / Supply	Active sensor 0-10 V or 4-20 mA (power supply 24 Vac/Vdc $\pm 10\%$), 3-4 wires
	Passive loop 4-20 mA (power supply 16/30 Vdc), 2 wires
Consumption	Common mode voltage <30 VAC Maximum load: 500 Ohms (4-20 mA) Minimum load: 1 K Ohms (0-10 V)
	CP 111: 3 VA (0-10 V) or 3 VA (4-20 mA)
European directives	2014/30/EU EMC; 2014/35/EU Low Voltage; 2011/65/EU RoHS II; 2012/19/EU WEEE
Electrical connection	Screw terminal block for cables from 0.05 to 2.5 mm ² or from 30 to 14 AWG. Carried out according to the code of good practice
Communication PC	USB-mini DIN cable
Environment	Air and neutral gases

Settings and use of the transmitter

Auto-calibration

CP 111 pressure transmitter has a temperature compensation of the gain from 0 to 50 °C and an auto-calibration process that guarantees over the time an excellent stability and a perfect reliability of the measurement on low and high ranges.

Configuration

The configuration of the parameters can be done either with the DIP switch or via software (you cannot combine both solutions). To configure the transmitter, unscrew the 4 screws from the housing then open it. DIP switches allowing the different settings are then accessible.



To configure the transmitter, it must not be energized. Then, you can make the settings required, with the DIP switches (as shown on the drawing below). When the transmitter is configured, you can power it up.

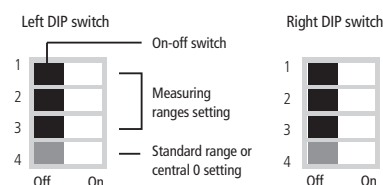

For detailed combinations of DIP switches, refer to the CP 110 Quick Start Guide.

Configuration via PC

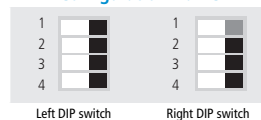

Refer to the user manual of the LCC-S to make the configuration.

Connections

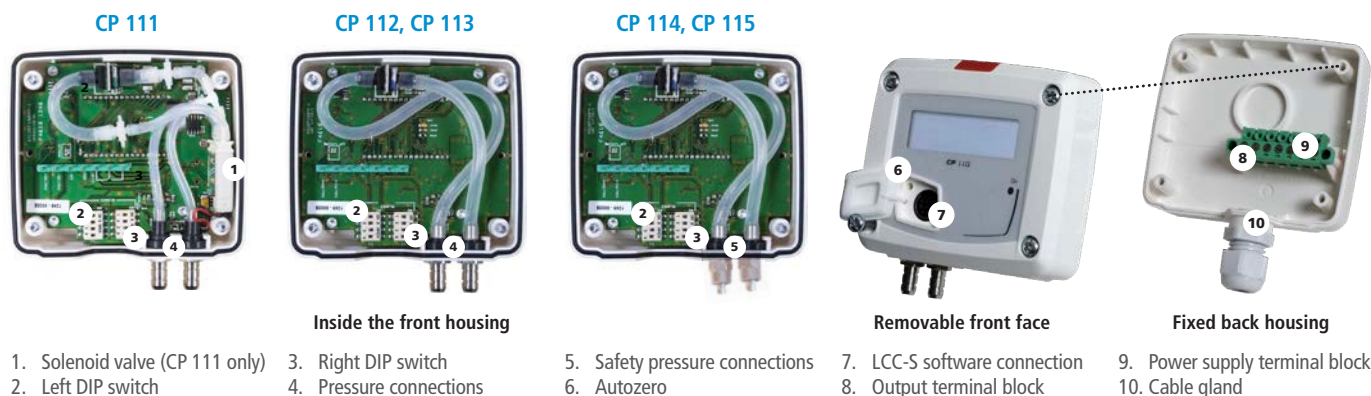

1. Solenoid valve (CP 111 only)
2. Left DIP switch
3. Right DIP switch
4. Pressure connections
5. Safety pressure connections
6. Autozero
7. LCC-S software connection
8. Output terminal block
9. Power supply terminal block
10. Cable gland

Mounting

To mount the transmitter, mount the ABS plate on the wall (drilling: $\varnothing 6$ mm, screws and pins are supplied). Insert the transmitter on the fixing plate (see A on the drawing beside). Rotate the housing in clockwise direction until you hear a "click" which confirms that the transmitter is correctly installed.



Once the transmitter is installed and powered up, please make an autozero to guarantee the correct working of the transmitter in any position.

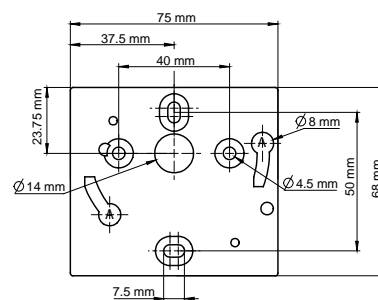

Maintenance: please avoid any aggressive solvent. Please protect the transmitter and its probes from any cleaning product containing formalin, that may be used for cleaning rooms or ducts.

Precautions for use: please always use the device in accordance with its intended use and within parameters described in the technical features in order not to compromise the protection ensured by the device.

Accessories

Ref.	Description
KIAL-100A	Power supply class 2, 230 Vac input, 24 Vac output
KIAL-100C	Power supply class 2, 230 Vac input, 24 Vdc output
LCC-S	Configuration software with USB cable

Connection tube, connection fittings, through-connections, straight connections, spherical coupling nut



Only the accessories supplied with the device must be used.

Warranty

Instruments have 1-year guarantee for any manufacturing defect.