



LH41A

Clamp On Ammeter

User Manual



LH41A

Clamp On Ammeter

Users Manual

English

April 2007, Rev.2
©2007 Amprobe Test Tools.
All rights reserved. Printed in China

Limited Warranty and Limitation of Liability

Your Amprobe product will be free from defects in material and workmanship for 1 year from the date of purchase. This warranty does not cover fuses, disposable batteries or damage from accident, neglect, misuse, alteration, contamination, or abnormal conditions of operation or handling. Resellers are not authorized to extend any other warranty on Amprobe's behalf. To obtain service during the warranty period, return the product with proof of purchase to an authorized Amprobe Test Tools Service Center or to an Amprobe dealer or distributor. See Repair Section for details. THIS WARRANTY IS YOUR ONLY REMEDY. ALL OTHER WARRANTIES - WHETHER EXPRESS, IMPLIED OR STATUTORY - INCLUDING IMPLIED WARRANTIES OF FITNESS FOR A PARTICULAR PURPOSE OR MERCHANTABILITY, ARE HEREBY DISCLAIMED. MANUFACTURER SHALL NOT BE LIABLE FOR ANY SPECIAL, INDIRECT, INCIDENTAL OR CONSEQUENTIAL DAMAGES OR LOSSES, ARISING FROM ANY CAUSE OR THEORY. Since some states or countries do not allow the exclusion or limitation of an implied warranty or of incidental or consequential damages, this limitation of liability may not apply to you.

Repair





All test tools returned for warranty or non-warranty repair or for calibration should be accompanied by the following: your name, company's name, address, telephone number, and proof of purchase. Additionally, please include a brief description of the problem or the service requested and include the test leads with the meter. Non-warranty repair or replacement charges should be remitted in the form of a check, a money order, credit card with expiration date, or a purchase order made payable to Amprobe® Test Tools.

In-Warranty Repairs and Replacement – All Countries

Please read the warranty statement and check your battery before requesting repair. During the warranty period any defective test tool can be returned to your Amprobe® Test Tools distributor for an exchange for the same or like product.

Non-Warranty Repairs and Replacement – US and Canada

Non-warranty repairs in the United States and Canada should be sent to a Amprobe® Test Tools Service Center. Call Amprobe® Test Tools or inquire at your point of purchase for current repair and replacement rates.

International Electrical Symbols	
	Caution! Refer to this manual before using the meter
	Meter is protected by Reinforced or Double Insulation
	Complies with EU directives
	Indicates this equipment should for disposal be separated as Waste Electrical and Electrical Equipment according to the EU directive 2002/96/EG
	Indicates item is a Type A Current sensor and that application around removal from HAZARDOUS LIVE conductors is permissible

CONTENTS	Page
1 INTRODUCTION	2
2 SPECIFICATIONS	3
2.1 Electrical Data	3
2.2 General Data	3
3 OPERATING INSTRUCTIONS	4
3.1 Switch On	4
3.2 Zero Adjustment	4
3.3 Current Measurement	4
3.4 Data Hold	4
3.5 Auto Power Off.....	4
4 SAFETY	5
5 BATTERY REPLACEMENT	6
6 WARRANTY	6
7 OTHER PRODUCTS	7

INTRODUCTION

The LH41A current clamp meter has been designed for reliable and accurate non-intrusive measurement of DC and AC currents using advanced Hall Effect technology.

Measurement features include:

- Non - intrusive AC and DC current measurement
- 1mA resolution
- Average responding, RMS calibrated
- Autoranging/ Autozeroing
- Data Hold
- Low battery indicator
- Auto Power Off

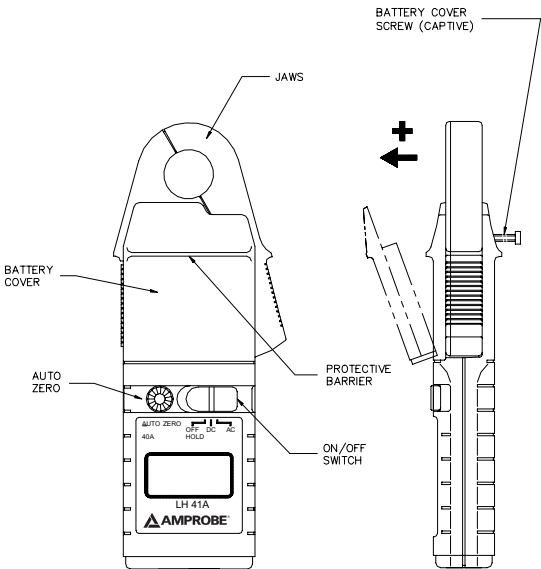

Fig. 1

SPECIFICATIONS

2.1 Electrical Data

(All accuracies stated at 23°C ± 1°C)

LH41A

Measuring Range	0 - 40 A DC or AC pk
Autoranging	4A / 40A
Resolution.....	1 mA in 4 A range 10 mA in 40 A range
Accuracy	
Basic Accuracy.....	± 1.3% + 5 digits
Temperature coefficient ...	± 0.05% of rdg / °C
Frequency range.....	DC in DC 40 Hz to 400 Hz in AC
Overload capacity.....	150 A
Dielectric strength.....	3.7 kV RMS. 50 Hz 60s (EN61010-2-032 Cat III, 300V Pollution Degree 2)

2.2 General Data

Operating temperature	0°C to + 50°C
Storage temperature with Battery removed.....	- 20°C to + 60°C
Power supply	9 V, Alkaline battery PP3, NEDA 1604 or IEC6LR61
Battery life	15 hours dependent duty cycle
Display.....	4000 count
Characters.....	10 mm high

Mechanical

LH41A

Dimensions	184 x 71 x 31 mm (7.2 x 2.8 x 1.2 in.)
Max. jaw capacity.....	19 mm ø cable
Max. jaw opening	20 mm (.78 in.)
Weight	235 g (1.2 Lb)

OPERATING INSTRUCTIONS

Refer to Fig. 1 for the main operating features of the meter.

3.1 Switch On

Move the switch from the OFF / HOLD position to either DC or AC to select the required mode of operation.

3.2 Zero Adjustment

When in DC mode the display zero may change due to thermal shifts and other environmental conditions. An auto zero adjustment is provided. Proceed as follows to perform the adjustment:

- Ensure that the instrument is away from the current carrying conductor and that the jaws are closed during the adjustment cycle.
- Select the DC position of the power switch.
- Use the auto zero button to zero the display if necessary.

The auto zero button can be used to null the effects of the earth's magnetic field on DC measurements.

3.3 Current Measurement

Select as required the DC or AC measurement option using the power switch.

If necessary adjust the DC display to read zero as described in section 3.2. Clamp the jaws of the instrument around the conductor ensuring a good contact between the closing faces of the jaws.

Observe and take measurements as required. Positive output indicates that the current flow is in the direction shown by the arrow on the instrument.

3.4 Data Hold

To activate the data hold, turn the power switch to the OFF / HOLD position. The data will be held on the display for approximately 10 seconds.

3.5 Auto Power Off

The meter will power down automatically after approximately 8 minutes of inactivity.

SAFETY

This product conforms to the latest directives concerning safety and electromagnetic compatibility.

- European Low Voltage Directives 73/23/EEC and 93/68/EEC
- European EMC Directives 89/336/EEC and 93/68/EEC

Safety Standards

BSEN61010-1: 2001. General Requirements.

Safety requirements for electrical equipment for measurement, control and laboratory use.

BSEN61010-2-032: 2002. Particular requirements for hand held current clamps for electrical measurement and test.

EMC Standards

RF Susceptibility

EN50082-1: 1992 3V/m Residential, Commercial and Light Industry

RF Emissions

EN50081-1: 1992 Residential, Commercial and Light Industry

FCC Part 15 Class B

This product is designed to be safe under the following conditions:

- indoor use
- altitude up to 2000m
- temperature 0°C to +50°C
- maximum relative humidity 80% for temperatures up to 31°C decreasing linearly to 40% relative humidity at 50°C.

Use of the meter on **uninsulated conductors** is limited to 300V RMS or DC and frequencies below 1kHz.

This meter complies with the requirements of the above safety standard for 300V Cat III Pollution degree 2

Safety in its use is the responsibility of the operator who must be a suitably qualified or authorised person.

Users of this equipment and or their employees are reminded that Health and Safety Legislation require them to carry out valid risk assessments of all electrical work so as to identify potential sources of electrical danger and risk of electrical injury such as from inadvertent short circuits.

Do not use the instrument if any part of it appears to be damaged or if a malfunction of the instrument is suspected.

When using the instrument ensure that your fingers are behind the **protective barrier** see Fig. 1

Clean the case periodically by wiping it with a damp cloth and detergent. Do not use abrasive cleaners or solvents. Do not immerse the instrument in liquids.

BATTERY REPLACEMENT

SAFETY WARNING

Before removing the battery cover, make sure that the instrument is removed from any live electrical circuit.

When the Low Battery symbol is illuminated in the display the minimum operating battery voltage has been reached. Refer to Fig.1. and use the following procedure to replace the battery.

Unclamp the meter from the conductor, turn it off using the OFF / Hold power switch. Loosen the captive screw which secures the battery cover. Lift the cover through 30° and pull it clear of the instrument body as shown in Fig1. The battery is then accessible. Replace the battery and re-fit the battery cover and fasten the screw.

Replacement with other than the specified type of battery will invalidate the warranty. Fit only Type 9 V PP3, Alkaline (MN1604).