



## MARK II Wind Speed Indicator

### Instructions and Operation



#### OPERATION

The Dwyer Mark II Wind Speed Indicator is 100% pneumatic. It operates on the time proven principle of aircraft speed indicators. The complete kit consists of a pick up vane connected by fifty feet of flexible double column tubing to the Mark II Indicator, plus all necessary mounting hardware, fluid and instructions.

In operation, wind aligns the Mark II weather vane pointing the pick up tube into the wind. Wind pressure enters and is transmitted through plastic connecting tubing to red fluid inside the indicator. Fluid level rises and falls in response to changing wind speed. Scale calibrations on the indicator show the wind speed corresponding to various fluid levels. For wind direction, observe the weather vane position.

#### INSTALLATION

1. Mount the weather vane assembly outdoors, as high as possible and away from the diverting effects of trees, roof pitch, and

other structures. A minimum of 5 to 10 feet of clearance is recommended for mounting above small or medium sized buildings and 15 to 20 feet for large buildings. Attach the mounting bracket directly to the pole or television antenna tower with the hardware provided. It will not interfere with T.V. reception. Assemble the roof top unit as shown in diagram on page 3. Use the curved slot to adjust the pick up unit to a vertical position. Tighten all screws. Make sure weather vane rotates freely.

2. Thread the dual column tubing through slots in the mounting bracket and tape loosely as necessary to relieve strain. Separate the two tubes for several inches and slip the red striped tube over the top pipe on pick up assembly. The plain tube slips over the lower pipe.

3. Run tubing to the desired indicator location. It can be installed either inside or outside. Use plastic tube clamps (Part No. 285)

to prevent pinching or stretching tubing. Free passage of air through both tubes is vital for accurate readings.

4. Mount the Mark II Indicator loosely with top screw. Center the bubble in spirit level, then install bottom screw. Tighten the screws keeping the level bubble centered.

5. Back the zero set knob all the way out, then turn back in three full turns. Remove reservoir "fill" plug and carefully fill indicator until red gage fluid rises to "zero" mark on scale. Use zero set knob for final adjustment then replace fill plug. Should you overfill, fluid may be removed by using a pipe cleaner to absorb excess fluid in the reservoir.

6. Cut off excess connecting tubing, separate the tubes slightly, and slip the red striped tube over left connector at top of instrument (above fill plug). Plain tube is similarly connected to right (or more centered) connector. The Wind Speed Indicator should now be in operation. If tube connections are reversed, a negative indication will result.

## **MAINTENANCE**

1. Periodically, disconnect the tubing from the indicator and adjust fluid level to zero mark. Add fluid if necessary, but do not use substitutes. Indicator may be wiped off with damp cloth as necessary.

2. Occasionally check weather vane (Part No. 162). It should rotate freely. Pull up to clean out spider nests, dirt, etc. Openings to tubing connections in body should be clear and free of any restriction.

3. Gently, but firmly pull out the static plate assembly (Part No. 164). Check drain hole to make certain it is open. If necessary, clean entire plastic roof top assembly in soap and water with soft brush or pipe cleaner. When reassembling static plate and weather vane, make certain they are pushed back firmly to prevent their coming apart in service.

4. Check connecting tubing (Part No. 290). It must not be kinked or flattened at any point. Cut or worn through spots will cause leaks and destroy the accuracy of the instrument. Such leaks must be repaired or the entire tubing replaced.

5. Rainwater or indicator fluid may occasionally enter the tubing and will cause erroneous readings. The drain system in the roof top pick up unit has been carefully designed to expel rainwater in normal quantities. Presence of water in the connecting tubing indicates that the drain system is plugged and should be cleaned or that the pick up unit is mounted in a location where air flow is upward (such as too close to a peaked roof) so that rainwater remains airborne in excessive quantities.

Gage fluid in the tubing indicates low fluid level, improper zero adjustment or wind gusts in excess of 90 MPH (145 KPH). It may be difficult or impossible to remove this liquid. Test for presence of obstruction or water in tubing on a day with no wind. Remove tubing connections from the gage, adjust zero set, blow gently into one tube at a time and attach to gage quickly. If reading does not stay at zero, there is fluid in the tubing. To correct, hang tubing vertically from center with ends down for several days. Reconnect and retest. If condition persists, the tubing should be replaced.

## **CAUTION:**

Do not blow into gage or weather vane! Gage fluid may be forced out of the opposite indicator connection into the tubing or onto your wall or carpet causing difficult to remove oil spots and stains.

## **NOTE:**

Heavy wind driven snow will sometimes enter pick up and temporarily affect readings until it thaws or evaporates.

**BEAUFORT SCALE OF WIND FORCE**

Beaufort Number	Miles per Hour	Knots	Descriptive Term	Beaufort Number	Miles per Hour	Knots	Descriptive Term
0	Less than 1	Less than 1	Calm	7	32-38	28-33	Near Gale
1	1-3	1-3	Light Air	8	39-46	34-40	Gale
2	4-7	4-6	Light Breeze	9	47-54	41-47	Strong Gale
3	8-12	7-10	Gentle Breeze	10	55-63	48-55	Storm
4	13-18	11-16	Moderate	11	64-72	56-63	Violent Storm
5	19-24	17-21	Fresh	12 or more	73 or more	64 or more	Hurricane
6	25-31	22-27	Strong				

**WIND CHILL EFFECT**

Wind Speed  
M.P.H.

	5	10	15	20	25	30	35	40
35	33	21	16	12	7	5	3	1
30	27	16	11	3	0	-2	-4	-5
25	21	9	1	-4	-7	-11	-13	-15
20	16	2	-6	-9	-15	-18	-20	-22
15	12	-2	-11	-17	-22	-26	-27	-29
10	7	-9	-18	-24	-29	-33	-35	-36
5	1	-15	-25	-32	-37	-41	-43	-45
0	-6	-22	-33	-40	-45	-49	-52	-54
-5	-11	-27	-40	-46	-52	-56	-60	-62
-10	-15	-31	-45	-52	-58	-63	-67	-69
-15	-20	-38	-51	-60	-67	-70	-72	-76
-20	-26	-45	-60	-68	-75	-78	-83	-87

**Wind Chill Temperature**

Extreme danger of frostbite to exposed flesh exists at wind chill temperatures below -22° F.

## Wind Speed Indicator Parts

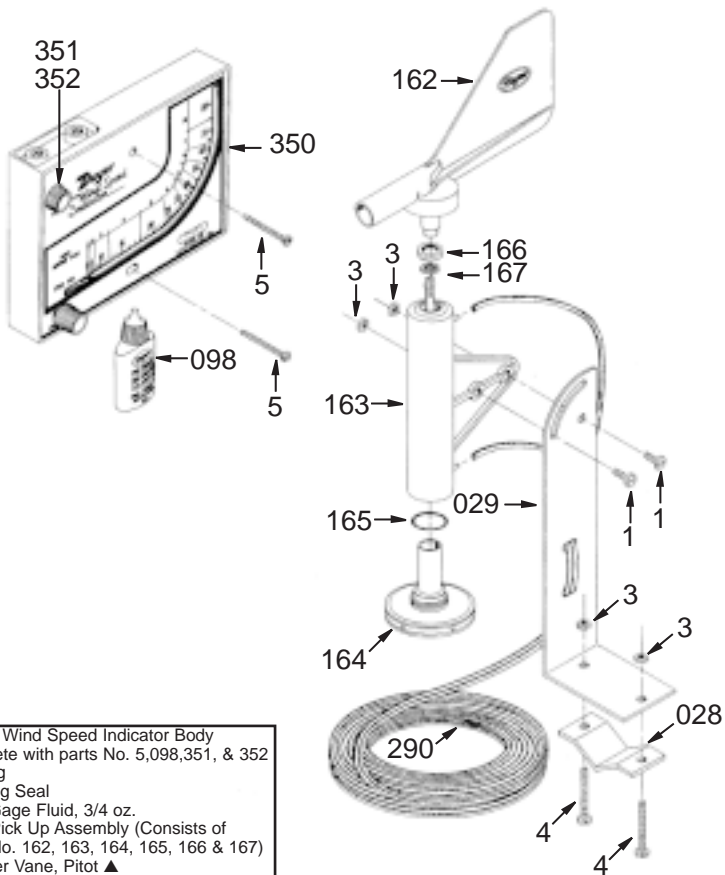

350	Mark II Wind Speed Indicator Body Complete with parts No. 5,098,351, & 352
351	Fill Plug
352	"O" Ring Seal
098	Wind Gage Fluid, 3/4 oz.
160	Wind Pick Up Assembly (Consists of Parts No. 162, 163, 164, 165, 166 & 167)
162	Weather Vane, Pitot ▲
163	Pick Up Body ▲
164	Static Pressure Plates ▲
165	"O" Ring Seal ▲
166	Top Bearing (Large) ▲
167	Bottom Bearing ▲
020	Roof Top Mounting Kit (Consists of Parts No. 028, 029, 1, 3 & 4)
028	Antenna Clamp
029	Mounting Bracket
290	Double Column Tubing, 50 ft.
285	Tube Clamps (Not shown) Package of 6
1	(2) No. 10-32 x 1/2" Machine Screw*
3	(4) No. 10-32 Nut*
4	(2) No. 10-32 x 1 3/4" Machine Screw*
5	(2) No. 8 x 1 3/4" Self Tapping Screw*

\*Standard hardware item. May be purchased locally.

▲ We recommend the purchase of the complete wind pickup assembly. Replacement parts may not fit older assemblies.