



BlackMax™ 2-Valve Piston Manifold **Manifold Operating Instructions**

<<<WARNING>>>

Follow good safety practices when working with refrigerants and refrigerant equipment. Safety goggles should be worn at all times. Refrigerant and lubricant vapor or mist may cause injury, frostbite, irritate eyes, nose and throat. Avoid breathing or contact with skin. Always point hose away from you and anybody near or around you. Remove hoses with care as they may be under high pressure with refrigerants. Improper procedures can cause refrigerant gas under pressure to explode violently. This equipment is intended for use by experienced professional service technicians in the refrigeration and/or air-conditioning who are familiar with the equipment they are servicing. Review the material safety data sheet (MSDS) provided by the refrigerant manufacturer for safe and proper handling information as well as instructions as to what to do if an emergency should arise.

2-WAY MANIFOLD FUNCTION

1. The right side hand knob (red high side) will control the flow of ports on that side to the center port and the port on the left side (blue low side) providing the low side hand knob is in the open position.
2. Should the flow be needed only through the center port (yellow line) close the low side blue label hand knob.
3. The low (blue) side operates in the same manner as on the high (red) side.
4. Pressure gauges and compound gauges are color coded accordingly.
5. The gauges will indicate either vacuum or pressure whether the hand knobs are in the open or closed positions, (if the hoses are connected to either a refrigerant supply tank, recovery unit, A/C system or vacuum pump etc).

EVACUATING PROCEDURE

1. Remove all refrigerant from the system. NOTE: It is unlawful to discharge or exhaust refrigerants into the atmosphere. CPS strongly recommends the practice of recovery or recycling.
2. Connect a vacuum pump to the center yellow charging hose.
3. Connect the high side service valve of the system to the right side red charging hose.
4. Connect the low side service valve of the system to the left side blue hose.
5. Fully open the high and low side hand knobs.
6. Start the vacuum pump.
7. Evacuate the system according to the manufacturer's specifications; close the high and low side hand knobs.
8. Turn off the vacuum pump.
9. Disconnect the yellow charging hose at the vacuum pump end and connect it to the refrigerant supply tank. (Make sure to turn shut off valve, off before disconnecting).

10. Slightly open the valve on the refrigerant supply tank and purge the air from the yellow hose at the manifold by loosening the yellow hose fitting, the close fitting and container valve.

CHARGING PROCEDURE

1. Follow the manufacturer's recommended specification for the amount of refrigerant to charge in that system. Should it specify to charge the system on that high side, close the low side service valve. Open the refrigerant supply container valve, then open the high side (red label) hand knob of the manifold. After the proper amount of refrigerant has been transferred, close the high red label hand knob of the manifold; also close the refrigerant supply container valve.
2. When the proper charge has been achieved, open the low side service valve on the system.
3. Run the compressor as per the manufacturer's specifications and observe the pressure gauge reading and compare to the manufacturer's specifications to determine that the system is operating correctly. If no adjustments need to be made, then read step 4. If not, follow proper procedures to repair or adjust the system.
4. Close the high and low side service valve of the system before removing the charging hoses from the system. Follow all safety practice procedures.

WARNING: Remove all hoses with care as they may contain refrigerant.

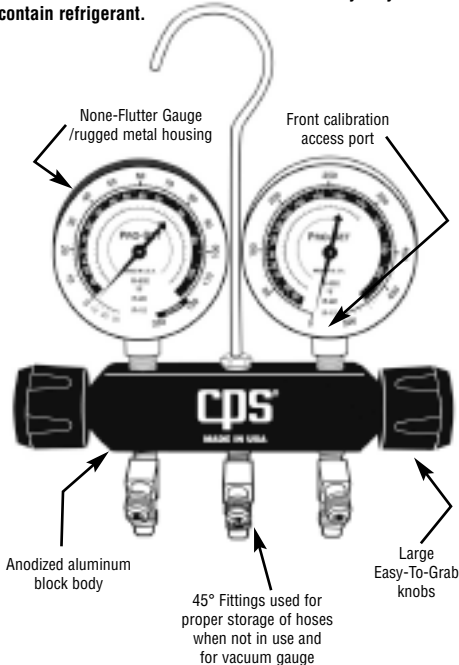

KEY FEATURES

- A. ANODIZED ALUMINUM MANIFOLD WITH LARGE EASY GRIP HAND KNOBS.
- B. DIAPHRAGM VALVES WITH SWIVEL SEATS FOR MORE POSITIVE SEAL AND LESS WEAR.
- C. FLUTTER FREE GAUGES.
- D. EXTRA LARGE PORT HOLES FOR FASTER RECOVERY OR CHARGING.
- E. EASY TO READ DIAL FACES.
- F. SHOCK RESISTANT MOVEMENT.
- G. ONE FULL TURN POSITIVE OPEN AND CLOSE VALVES.
- H. EXTRA LARGE SIGHTGLASS.

Pro-Set Manifolds are designed for field service and with routine care will last for many years (as with all CPS products). The diaphragm valve is designed for long life using good wear resistant materials, as well as incorporating a swivel seat which will assure a perfect seal and prevent additional wear on the diaphragm. Our large hand knobs cover the valve stem to keep dirt and debris away from the diaphragm and threads. The hand knobs are designed to open and close with one full turn, while utilizing fingertip pressure. An over size scratch resistant sight glass has been designed into this manifold to give you better visibility of the refrigerants. The gauges were designed with the user in mind. Flutter free pointer provides steady and accurate pressure readings without using fluids that may eventually leak, as well as a shock resistant suspended movement that seldom needs recalibration.

**WARRANTY
and
REPAIR
POLICY**

CPS PRODUCTS, INC guarantees that all products are free of manufacturing and material defects to the original owner for one year from date of purchase. If an instrument should fail during the guarantee period it will be repaired or replaced (at our option) at no charge. This guarantee does not apply to instruments, which have been altered, misused, or returned solely in need of field service maintenance. All repaired instruments will carry an independent 90-day warranty. This repair policy does not include instruments, which are determined to be beyond economical repair.

- Advanced one-piece diaphragm valve design
- Superior refrigerant metering capabilities
- Vacuum rated to 15 microns or better
- Certified 5 year trouble-free valve life
- Maximum unrestricted refrigerant flow
- Light touch valve operation
- Advanced VVS diaphragm valve system
- Red & blue protective gauge boots
- Anodized aircraft aluminum block body
- Heavy duty metal valve handles
- Certified 15 micron vacuum rating
- New 45° fittings for easy hose storage (2 valve series only)
- Precision flutter-free metal cased gauges
- Oversized refrigerant sight glass

TRIPLE SEAL™ VALVES

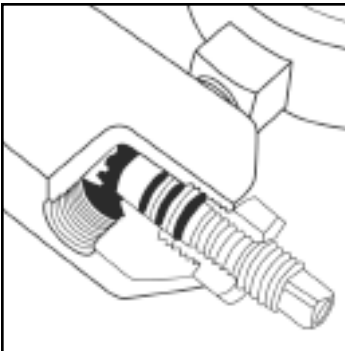

BLACKMAX MANIFOLDS

MXC	Manifold carrying case
MXMH	Hook assembly (qty 1)
MXPK	BlackMax piston valve handle (qty 1)
MXPV	Complete BlackMax piston valve assembly (qty 1)
MXPVO	BlackMax piston valve o-ring kit (services 2 valves)
40-398	45° Tee 1/8MNPT x 1/2-20 UNF M x 1/2"-20UNF M w/core (qty 1)
40-399	45° Tee 1/8MNPT x 1/2-20 UNF M x 1/2"-20UNF M (qty 2)
40-396	45° Tee 1/8MPT X 1/4" SAE M X 1/4" SAE M w/core (qty 1)
40-397	45° Tee 1/8MPT X 1/4" SAE M X 1/4" SAE M (qty 2)
40-388	45° Tee 1/8MNPT x 1/2" ACME M x 1/2" ACME M w/core (qty 1)
40-389	45° Tee 1/8MNPT x 1/2" ACME M x 1/2" ACME M (qty 2)
40-392	R-134a low coupler anchor
40-393	R-134a high coupler anchor

Test Equipment Depot - 800.517.8431 - 99 Washington Street Melrose, MA 02176

TestEquipmentDepot.com