

BVM

Battery Voltage Monitoring



- Enables automatic battery cell voltage measurements during capacity tests
- “Daisy-chain” design allows expandability up to 2x120 cells
- High accuracy and stability for precise data collection
- Wide voltage range
- Easy set-up with many options for connecting the BVM system to a battery bank

DESCRIPTION

The BVM equipment is a battery cell/block voltage measurement system performed on battery banks. It can be used in conjunction with a load device such as the TORQUEL. It can also be used to measure cell/block voltages from a PC with TORQUEL Win or PowerDB. The BVM system is designed in a modular form where one BVM unit is used for each cell or block in the battery string to be tested. One BVM unit for each cell or block connects to the next in a daisy chain fashion. The included dolphin clip can easily be removed and exchanged with different styles of standard banana plug clamps and/ or extension cables to accommodate any battery connection requirement.

Up to 2 x 120 BVMs can be daisy chained in a single battery bank under test that is used for the capacity testing of large, industrial battery banks commonly found in electrical power substations, telecom facilities and UPS systems generally. When used in conjunction with a load device (e.g. Megger TORQUEL) and test data management software (TORQUEL Viewer, PowerDB or TORQUEL Win) the BVM system facilitates the execution of an automated battery bank capacity test, according to IEC and IEEE standards. The test also meet NERC/FERC requirements. The BVM-system is designed in a modular form where one BVM device is used for each battery cell or “jar” in the string to be tested. One BVM for each battery connects to the next in a “daisy-chain” fashion, thereby providing easy and economical expandability to meet the testing requirements for small-to-large battery bank systems.

Setting up the BVM system for a test is quick and easy. Each BVM unit is identical and can be connected in any battery test position, thus providing maximum flexibility and interchangeability of the BVMs. The BVM “Auto Discovery” feature enables the host device to automatically determine the number of batteries under test and provide sequential identification of each BVM unit in the test string.

APPLICATION

Each BVM unit is identical and can be connected in any battery test position. A single cable connects the first BVM unit in the string to a Power & signal connector. The BVM system data output is connected via an Ethernet cable to the BVM USB port on TORQUEL900 or to a PC with data management SW, e.g. PowerDB or TORQUELWin. The BVM system can also be used together with older Megger TORQUEL versions, or any battery load bank. This will require the use of a separate PC with test management SW e.g. PowerDB or TORQUEL Win.

Connection example with TORQUEL 900

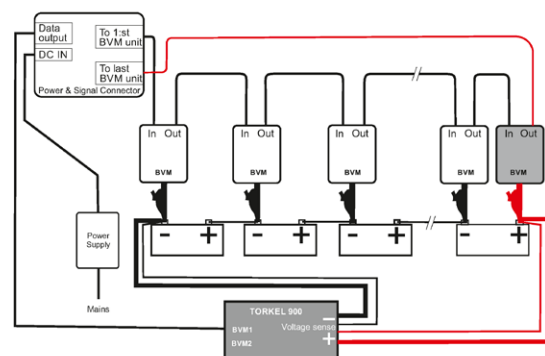

The red dolphin clip in the chain should be connected to the most positive battery pole in the battery bank. The voltage over each BVM device will be logged throughout the complete discharge test.

BVM Battery Voltage Monitoring

CONNECTION EXAMPLES

With TORQUEL 900

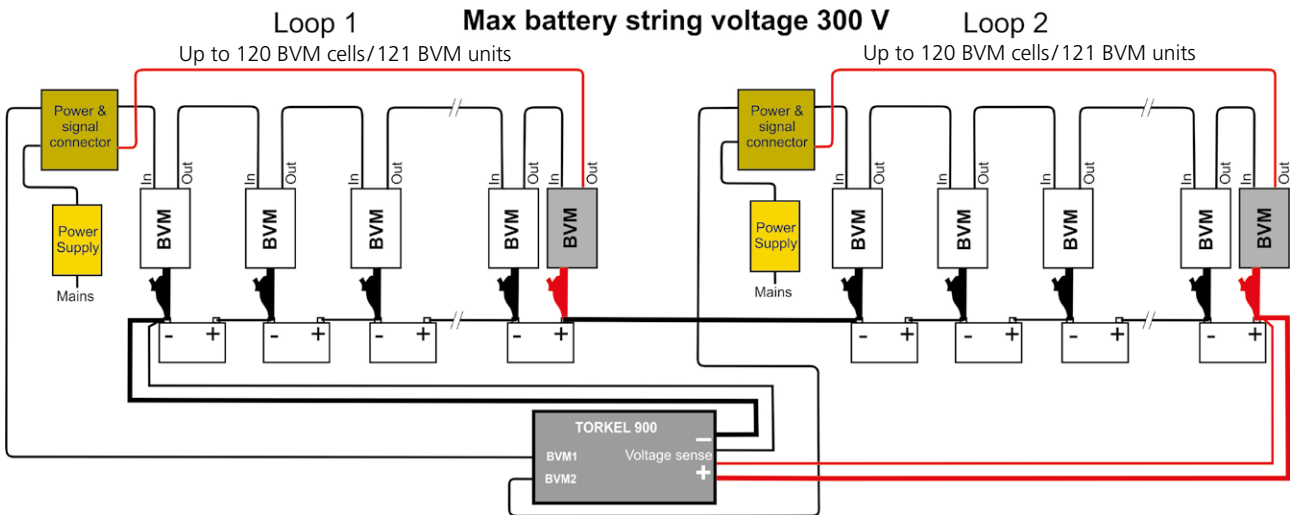

When the battery bank exceeds 120 cells, this connection with 2 BVM loops shall be used. Connect the first loop to the BVM1 USB port on TORQUEL900 and the second loop to the BVM2 USB port on TORQUEL900.

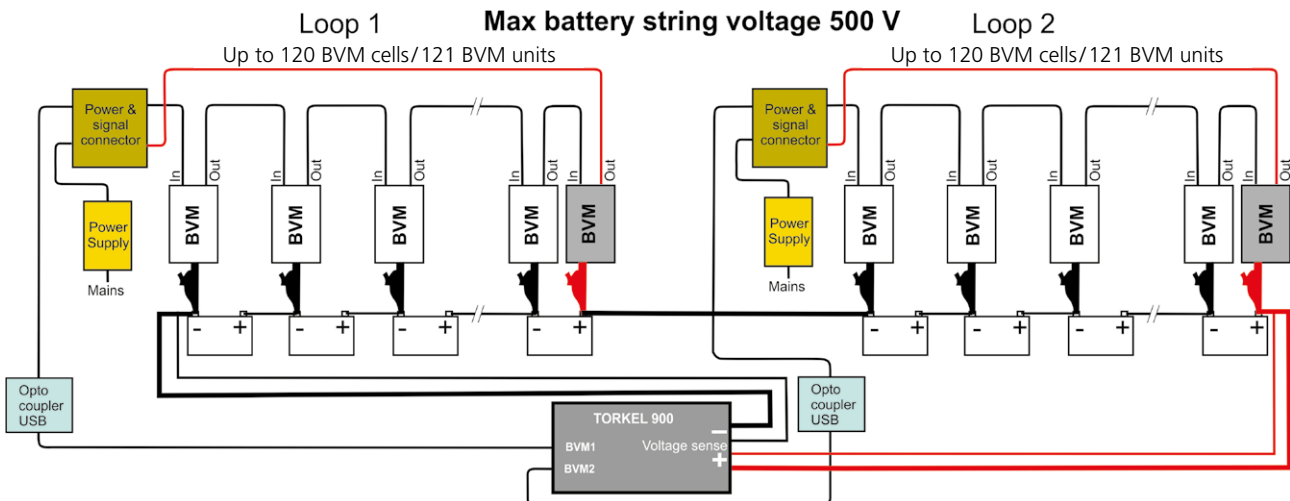

The connection shown above must be used when the battery bank voltage is between 300 V and 500 V. It includes two opto couplers and two ungrounded power supplies.



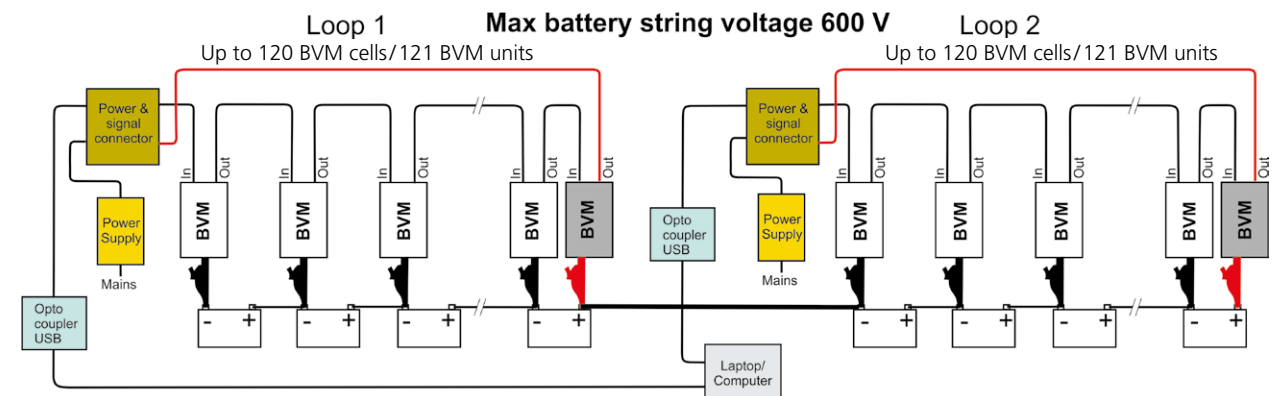



Without TORQUEL 900



When the total battery voltage exceeds 500 V, TORQUEL cannot be used as a load bank. Instead other load banks, or the existing UPS load can be used for doing battery capacity tests.

BVM Battery Voltage Monitoring

ACCESSORIES FOR CONNECTION OF BVM TO BATTERY

Included connectors for BVM unit to battery	
Dolphin clips 40-08320 black 40-08322 red	
Optional connections for BVM to battery	
Extension lead for connecting BVM unit, via clips or similar, to battery 04-30050	
Cable with M8 ring connector, 0.3 m (1 ft) KG-00690	
Cable with 6.3 mm insulated female flat connector, 0.3 m (1 ft) KG-00692	
Battery pole bolt M8, screw connection M4 40-06300	
Ground washer B1457-H8 45-10046	

OPTIONAL ACCESSORIES

PowerDB

PC software for BVM and TORQUEL 800/900-series. For BVM and TORQUEL 800 series it works for controlling, data management and report handling, for TORQUEL 900-series only for data management and reporting.

BVM Cal Kit

Calibration system for BVM units (CJ-90090)



Opto coupler USB

When the battery bank voltage exceeds 300V the BVM system must be used with opto couplers.



ADDITIONAL EQUIPMENT

For complete information on additional products see appropriate data sheets.

TORQUEL 900-series

Family of battery load units with automatic and dynamic discharge technology. The TORQUEL family is extremely flexible and scalable for various voltages and currents required. Please see separate data sheet for details.



SPECIFICATIONS

Specifications are valid at an ambient temperature of +25°C, (77°F). Specifications are subject to change without notice.

Environment

Application field The instrument is intended for use in battery rooms found in electric power generating and substations as well as in telecommunication infrastructure and UPS applications in general
Altitude <2000 m (6500 ft) above sea level.

Temperature

Operating 5°C to +50°C (41°F to +122°F)

Storage & transport 0°C to +60°C (32°F to +140°F)

Humidity 5% – 95% RH, non-condensing

CE-marking

LVD 2014/35/EU

EMC 2014/30/EU

RoHS 2011/65/EU

General

Mains voltage 100–240 V AC, 50/60 Hz

Power consumption 50 VA (max)

Protection Overvoltage, reverse voltage, voltage transients, ESD

Dimensions

BVM unit 75 x 64 x 25 mm
(3" x 2.5" x 1")

Carrying case 575 x 470 x 205 mm
(22.6" x 18.5" x 8.1")

Weight

BVM unit 0.07 kg (0.15 lbs)

With accessories and carrying case BVM system of 31 units 8.8 kg (19 lbs)
BVM system of 61 units 12.5 kg (27 lbs)

Measurement section

Maximum number of BVM units 242 (2 x 121)

Voltage range 0–20 V DC

Resolution 1 mV

Inaccuracy < 0.1% of full scale ±0.01 VDC

Battery string voltage 300 V DC (max per loop)

Measurement input impedance 1 MΩ

ORDERING INFORMATION

Item	Part No.
BVM Including: Dolphin clips, Power & signal connector, Power supply, Connection cables and Carrying case On request: TORDEL Win	
BVM150 System of 16 BVM units	CJ-59092
BVM300 System of 31 BVM units	CJ-59093
BVM600 System of 61 BVM units	CJ-59096
BVM special 600 V System of 46 BVM units ¹⁾ Incl. Dolphin clips, Power & signal connectors, Opto couplers, Power supplies, Connection cables and Carrying case.	CJ-59198
BVM Single unit	CJ-59090
Optional accessories	
PowerDB PC software for BVM and TORDEL 800/900-series. BVM and TORDEL 800 series: Control and report TORDEL 900-series: Only report Free to download from www.powerdb.us	
Opto coupler When battery bank voltage exceeds 300 V	HC-50040
Extension cable Extension lead for connecting BVM unit to battery, 0.5 m (1.6 ft)	04-30050
Cable with ring connector Cable with M8 ring connector, 0.3 m (1 ft)	KG-00690
Cable with insulated flat connector Cable with 6.3 mm insulated female flat connector, 0.3 m (1 ft)	KG-00692
Battery bolt adapter Battery pole bolt M8, screw connection M4	40-06300
Ground washer B1457-H8	45-10046
BVM Cal Kit Calibration system for BVM units	CJ-90090

1) The TORDEL 950 can handle a maximum of 500 V. Battery systems over 500 V and up to 600 V can be tested with BVM and PowerDB or TORDEL Win application on a computer.



BVM600 Transport case (CJ-59096)

Postal address
Megger Sweden AB
Box 724
SE-182 17 Danderyd
SWEDEN

BVM_DS_en_V11a
ZI-CJ01E • CJ0062KE • 2023
Subject to change without notice.
ISO 9001:2008
The word "Megger" is registered trademark

Megger