

Multi-Channel Function Generator

MFG-2000 Series

QUICK START GUIDE

GW INSTEK PART NO. 82MF-2K000M01



ISO-9001 CERTIFIED MANUFACTURER

GW INSTEK

This manual contains proprietary information, which is protected by copyright. All rights are reserved. No part of this manual may be photocopied, reproduced or translated to another language without prior written consent of Good Will Corporation.

The information in this manual was correct at the time of printing. However, Good Will continues to improve its products and therefore reserves the right to change the specifications, equipment, and maintenance procedures at any time without notice.

Good Will Instrument Co., Ltd.
No. 7-1, Jhongsing Rd., Tucheng Dist., New Taipei City 236, Taiwan.

Table of Contents

S	SAFETY INSTRUCTIONS.....	4
G	GETTING STARTED	9
	Main Features.....	9
	Panel Overview.....	11
	Setting Up the function Generator.....	21
Q	QUICK REFERENCE	23
	How to use the Digital Inputs.....	25
	How to use the Help Menu.....	27
	Selecting a Waveform	30
	Modulation.....	32
	Sweep.....	41
	Burst.....	43
	ARB.....	45
	Utility Menu	50
	Menu Tree	51
	Default Settings.....	63
	MFG-2000 Series Specifications	65
	EC Declaration of Conformity	71

S SAFETY INSTRUCTIONS

This chapter contains important safety instructions that should be followed when operating and storing the function generator. Read the following before any operation to ensure your safety and to keep the function generator in the best condition.

Safety Symbols

These safety symbols may appear in this manual or on the instrument.



Warning: Identifies conditions or practices that could result in injury or loss of life.



Caution: Identifies conditions or practices that could result in damage to the function generator or to other objects or property.



DANGER High Voltage



Attention: Refer to the Manual



Protective Conductor Terminal



Earth (Ground) Terminal



DANGER Hot Surface



Double Insulated



Do not dispose electronic equipment as unsorted municipal waste. Please use a separate collection facility or contact the supplier from which this instrument was purchased.

Safety Guidelines

General Guideline



CAUTION

- Do not place heavy objects on the instrument.
- Do not place flammable objects on the instrument.
- Avoid severe impact or rough handling that may damage the function generator.
- Avoid discharges of static electricity on or near the function generator.
- Use only mating connectors, not bare wires, for the terminals.
- The instrument should only be disassembled by a qualified technician.

(Measurement categories) EN 61010-1:2010 (Third Edition) specifies the measurement categories and their requirements as follows. The MFG-2000 falls under category II.

- Measurement category IV is for measurement performed at the source of a low-voltage installation.
 - Measurement category III is for measurement performed in a building installation.
 - Measurement category II is for measurement performed on circuits directly connected to a low voltage installation.
 - Measurement category I is for measurements performed on circuits not directly connected to Mains.
-

Power Supply



WARNING

- AC Input voltage: 100 ~ 240V AC, 50 ~ 60Hz.
Or 100 ~ 120V AC, 220 ~ 240V AC, 50 ~ 60Hz
(With power amplifier)
- Connect the protective grounding conductor of the AC power cord to an earth ground to prevent electric shock.

Fuse



WARNING

- Fuse type: T0.5A/250V. T1A/250V(With power amplifier).
- Only qualified technicians should replace the fuse.
 - To ensure fire protection, replace the fuse only with the specified type and rating.
 - Disconnect the power cord and all test leads before replacing the fuse.
 - Make sure the cause of fuse blowout is fixed before replacing the fuse.

Cleaning the function generator

- Disconnect the power cord before cleaning the function generator.
- Use a soft cloth dampened in a solution of mild detergent and water. Do not spray any liquid into the function generator.
- Do not use chemicals containing harsh products such as benzene, toluene, xylene, and acetone.

Operation Environment

- Location: Indoor, no direct sunlight, dust free, almost non-conductive pollution (Note below) and avoid strong magnetic fields.
- Relative Humidity: < 80%
- Altitude: < 2000m
- Temperature: 0°C to 40°C

(Pollution Degree) EN 61010-1:2010(Third Edition) specifies pollution degrees and their requirements as follows. The function generator falls under degree 2.

Pollution refers to “addition of foreign matter, solid, liquid, or gaseous (ionized gases), that may produce a reduction of dielectric strength or surface resistivity”.

- Pollution degree 1: No pollution or only dry, non-conductive pollution occurs. The pollution has no influence.
- Pollution degree 2: Normally only non-conductive pollution occurs. Occasionally, however, a temporary conductivity caused by condensation must be expected.
- Pollution degree 3: Conductive pollution occurs, or dry, non-conductive pollution occurs which becomes conductive due to condensation which is expected. In such conditions, equipment is normally protected against exposure to direct sunlight, precipitation, and full wind pressure, but neither temperature nor humidity is controlled.

Storage environment

- Location: Indoor
- Relative Humidity: < 70%
- Temperature: -10°C to 70°C

Disposal



Do not dispose this instrument as unsorted municipal waste. Please use a separate collection facility or contact the supplier from which this instrument was purchased. Please make sure discarded electrical waste is properly recycled to reduce environmental impact.

Power cord for the United Kingdom

When using the function generator in the United Kingdom, make sure the power cord meets the following safety instructions.

NOTE: This lead/appliance must only be wired by competent persons

 **WARNING: THIS APPLIANCE MUST BE EARTHED**

IMPORTANT: The wires in this lead are coloured in accordance with the following code:

Green/ Yellow:	Earth
Blue:	Neutral
Brown:	Live (Phase)



As the colours of the wires in main leads may not correspond with the coloured marking identified in your plug/appliance, proceed as follows:

The wire which is coloured Green & Yellow must be connected to the Earth terminal marked with either the letter E, the earth symbol  or coloured Green/Green & Yellow.

The wire which is coloured Blue must be connected to the terminal which is marked with the letter N or coloured Blue or Black.

The wire which is coloured Brown must be connected to the terminal marked with the letter L or P or coloured Brown or Red.

If in doubt, consult the instructions provided with the equipment or contact the supplier.

This cable/appliance should be protected by a suitably rated and approved HBC mains fuse: refer to the rating information on the equipment and/or user instructions for details. As a guide, a cable of 0.75mm² should be protected by a 3A or 5A fuse. Larger conductors would normally require 13A types, depending on the connection method used.

Any exposed wiring from a cable, plug or connection that is engaged in a live socket is extremely hazardous. If a cable or plug is deemed hazardous, turn off the mains power and remove the cable, any fuses and fuse assemblies. All hazardous wiring must be immediately destroyed and replaced in accordance to the above standard.

GETTING STARTED

The Getting started chapter introduces the function generator’s main features, appearance, set up procedure and power-up.

Main Features

MFG-2000 series specific functions						
Model	CH1	CH2	25MHz Pulse Generator	RF Generator (function with ARB)	Power Amplifier	Modulation /Sweep/Burst/ Frequency,Counter
	Function With 200MSa/sARB	Function With 200MSa/sARB				
MFG-2110	●10MHZ		●			
MFG-2120	●20MHZ		●			
MFG-2120MA	●20MHZ		●		●	●
MFG-2130M	●30MHZ		●			●
MFG-2160MF	●60MHZ		●	●160MHZ		●
MFG-2160MR	●60MHZ		●	●320MHZ		●
MFG-2230M	●30MHZ	●30MHZ	●			●
MFG-2260M	●60MHZ	●60MHZ	●			●
MFG-2260MFA	●60MHZ	●60MHZ	●	●160MHZ	●	●
MFG-2260MRA	●60MHZ	●60MHZ	●	●320MHZ	●	●

- Performance
- DDS Function Generator series
 - 1μHz high frequency resolution maintained at full range
 - 20ppm frequency stability
 - Arbitrary Waveform Capability
 - 200 MSa/s sample rate
 - 100 MSa/s repetition rate
 - 16k-point waveform length
 - 10 groups of 16k waveform memories
 - True waveform output to display

- User-defined output section
 - User-defined marker output section
 - DWR (Direct Waveform Reconstruction) capability
 - Ability to edit waveforms without a PC
 - -60dBc low distortion sine wave
-

Features

- Sine, Square, Ramp, Pulse, Noise waveforms
 - Internal and external LIN/LOG sweep with marker output
 - Int/Ext AM, FM, PM, FSK, SUM, PWM modulation
 - Burst function with internal and external triggers
 - 42Vpk signal ground chassis isolation
 - Pulse waveform with configurable rise times & fall times
 - Store/recall 10 groups of setting memories
 - Output overload protection
-

Interface

- USB interface as standard, LAN interface(MFG-22XX only)
- 4 inch Color TFT LCD (480 X 272) graphical user interface
- AWES (Arbitrary Waveform Editing Software) PC software

Panel Overview

MFG-2260MRA/2260MFA Front Panel

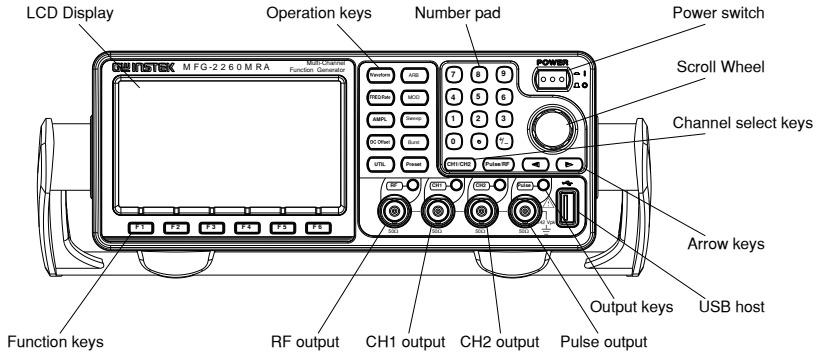

MFG-2160MR/2160MF Front Panel

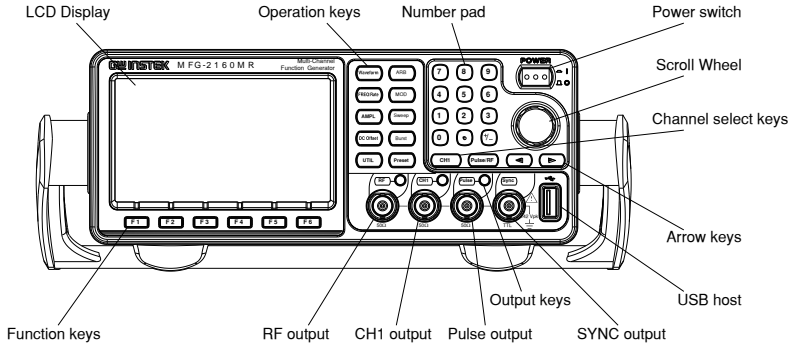

MFG- 2120MA/2130M Front Panel

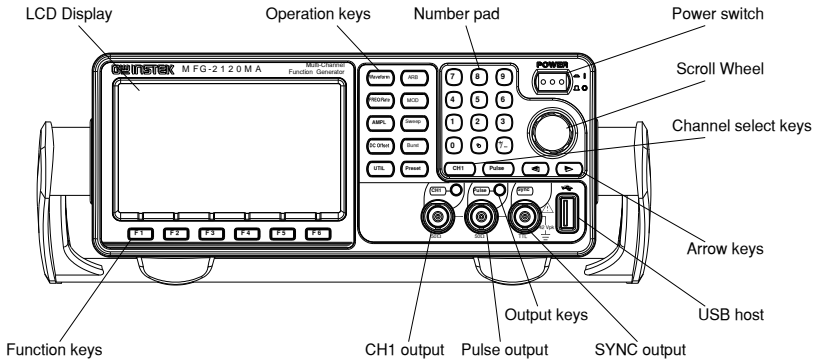

MFG- 2110/2120 Front Panel

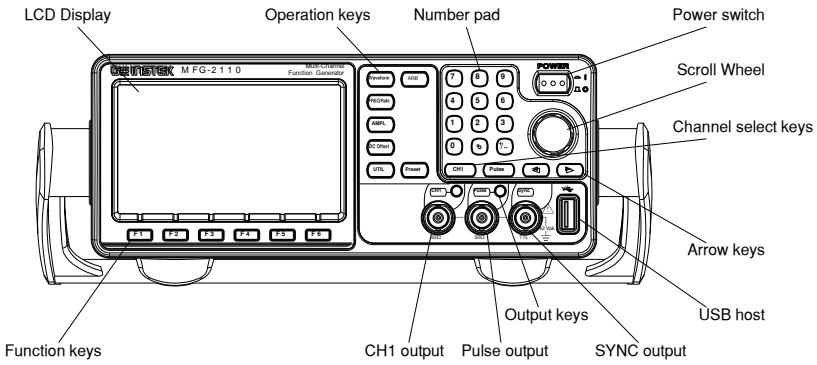

MFG- 2260M/2230M Front Panel

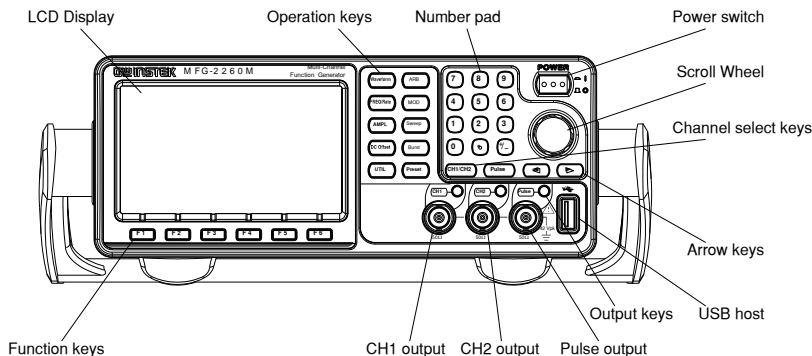

LCD Display TFT color display, 480 x 272 resolution.

Function
Keys
F1~F6



Activates functions that appear on the bottom of the LCD screen.

Operation
Keys



The waveform key is used to select a type of waveform.



The FREQ/Rate key is used to set the frequency or sample rate.



AMPL sets the waveform amplitude.



Sets the DC offset.



The UTIL key is used to access the save and recall options, update and view the firmware version, access the calibration options, system setting, Dual channel functions and frequency meter.



ARB is used to set the arbitrary waveform parameters.

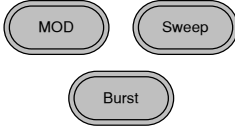

The MOD, Sweep and Burst keys are used to set the modulation, sweep and burst settings and parameters.

Preset Key



The preset key is used to recall a preset state.

Output Key



The Output key is used to turn on or off the waveform output.

Channel Select Keys



The channel select key is used to switch between the four output channels.

Output ports

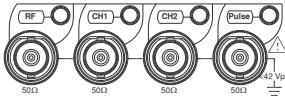

CH1: Channel 1 output port
 CH2: Channel 2 output port
 Pulse: Pulse output port
 RF: RF output port

Power Button



Turns the power on or off.

USB Host



USB type-A host port.

Arrow Keys



Used to select digits when editing parameters.

Scroll Wheel

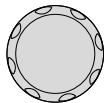

The scroll wheel is used to edit values and parameters.

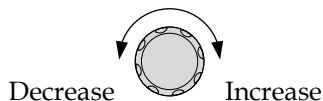

Keypad

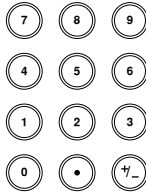

The digital keypad is used to enter values and parameters. The keypad is often used in conjunction with the arrow keys and variable knob.

MFG-2260MRA/2260MFA Rear Panel

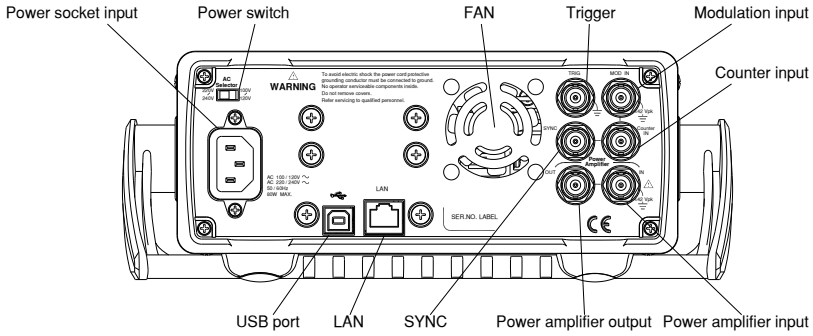

MFG-2120MA Rear Panel

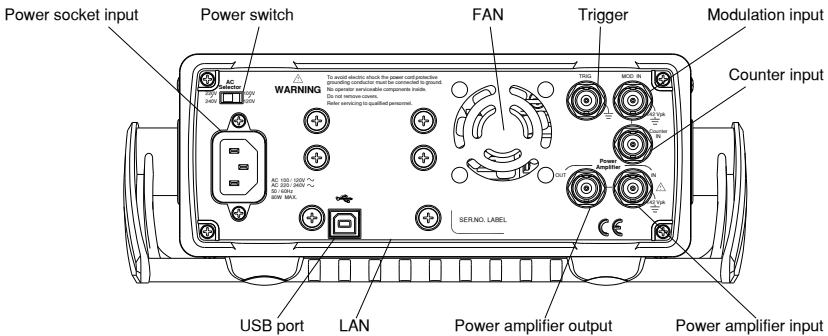

MFG-2160MR/2160MF/2130M Rear Panel

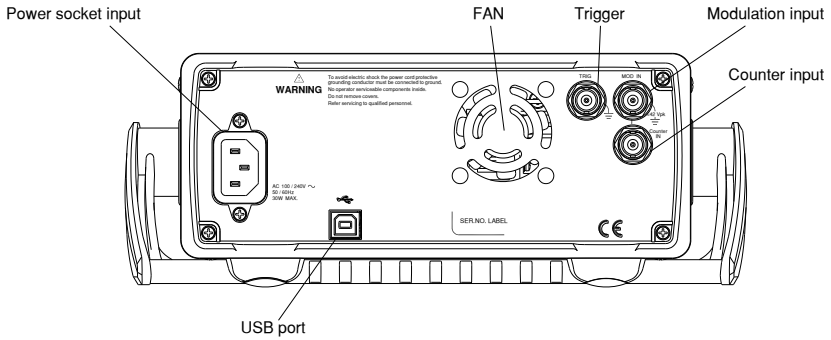

MFG-2260M/2230M Rear Panel

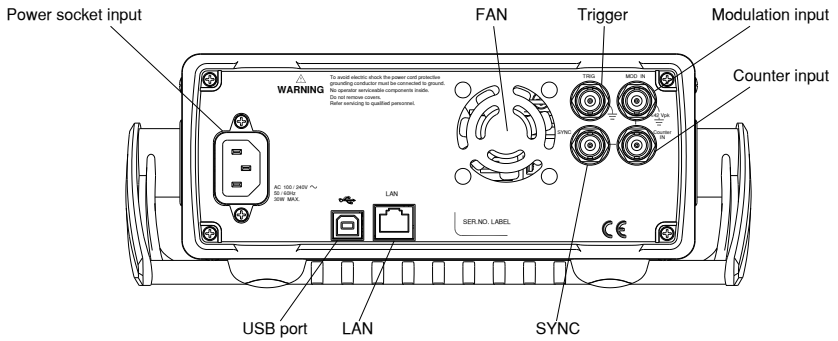

MFG-2110/2120 Rear Panel

Power socket input

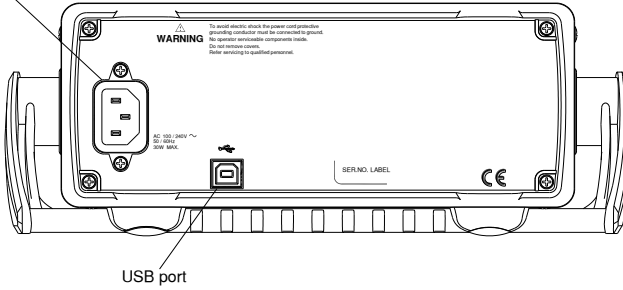

Trigger

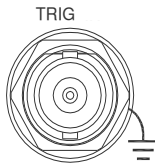

Input: External trigger

Output: Trigger out

Sync

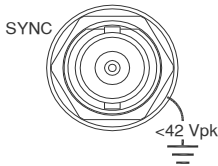

Sync output port

(Front panel:MFG-21XX

Rear panel:MFG-22xx)

Fan

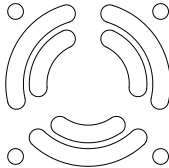

Fan.

Power Input
Socket

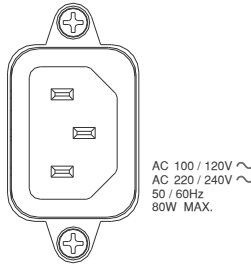

Power input:
100~240V AC
50~60Hz. Or
100~120V AC
220~240V AC
50~60Hz.

Power Switch

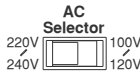

Selects AC voltage: 100V~120V
Or 220V~240V.

LAN Port

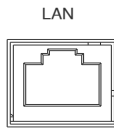

The LAN port is used for
remote control over a network
(MFG-22XX only)

USB Device
Port



USB type-B device port is used
to connect the function
generator to a PC for remote
control.

Counter Input

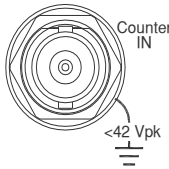

Frequency counter input.

MOD Input

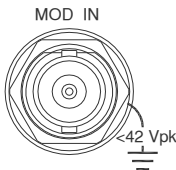

Modulation input terminal.

Power
Amplifier in

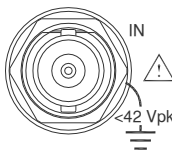

Power Amplifier input port

Power Amplifier out

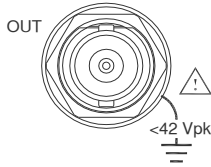

Power Amplifier output port

Display

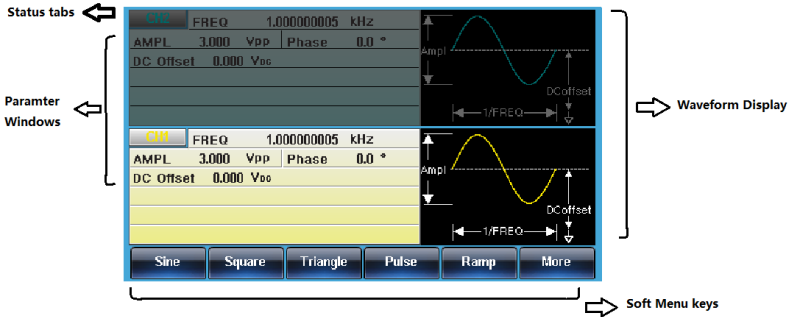

Parameter Windows

The Parameter display and edit window.

Status Tabs

Displays the current channel and setting status.

Waveform Display

Used to display the waveform

Soft Menu Keys

The function keys (F1~F6) under the LCD display correspond directly to the soft menu keys.

Setting Up the function Generator

Background This section describes how to adjust the handle and power up the function generator.

Adjusting the Handle

Pull out the handle sideways and rotate it.

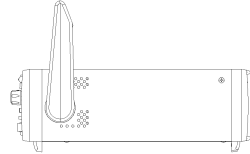

Place the MFG-2000 horizontally,

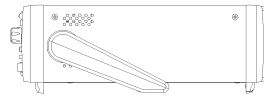

Or tilt the stand.

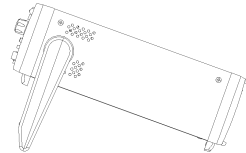

Place the handle vertically to hand carry.

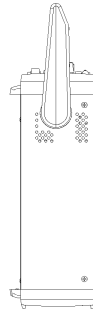

Power Up

1. Connect the power cord to the socket on the rear panel.

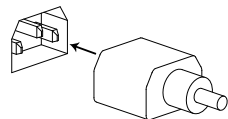

2. Turn on the power switch on the front panel.

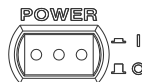

3. When the power switch is turned on the screen displays the loading screen.



The function generator is now ready to be used.

QUICK REFERENCE

This chapter describes the operation shortcuts, built-in help and factory default settings. This chapter is to be used as a quick reference, for detailed explanations on parameters, settings and limitations, please see the operation chapters.

How to use the Digital Inputs	25
How to use the Help Menu	27
Selecting a Waveform	30
Square Wave.....	30
Ramp Wave	30
Sine Wave.....	31
Modulation	32
AM.....	32
ASK Modulation	33
FM	34
FSK Modulation	35
PM Modulation	36
PSK Modulation	37
PWM Modulation.....	38
SUM Modulation	39
Sweep	41
Burst.....	43
ARB	45
ARB—Add Built-In Waveform.....	45
ARB—Add Point.....	45
ARB—Add Line	47
ARB—Output Section.....	47
ARB—Output N Cycle.....	48
ARB—Output Infinite Cycles	49
ARB—Output Marker	49
Utility Menu.....	50
Save	50

Recall.....	50
Menu Tree.....	51
Waveform.....	51
ARB-Display.....	52
ARB-Edit.....	53
ARB-Built In.....	54
ARB-Save.....	55
ARB-Load.....	56
ARB-Output.....	56
MOD.....	57
SWEEP.....	58
SWEEP- More.....	58
Burst-N Cycle.....	59
Burst-Gate.....	60
UTIL.....	61
CH1/CH2.....	62
CH3/RF.....	62

How to use the Digital Inputs

Background

The MFG-2000 has three main types of digital inputs: the number pad, arrow keys and scroll wheel. The following instructions will show you how to use the digital inputs to edit parameters.

1. To select a menu item, press the corresponding function keys below (F1~F6). For example the function key F1 corresponds to the Soft key "Sine".



2. To edit a digital value, use the arrow keys to move the cursor to the digit that needs to be edited.

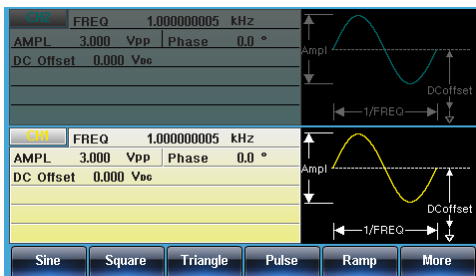

3. Use the scroll wheel to edit the parameter. Clockwise increases the value, counter clockwise decreases the value.

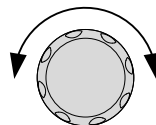

4. Alternatively, the number pad can be used to set the value of a highlighted parameter.

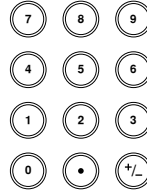

How to use the Help Menu

Background Every key and function has a detailed description in the help menu.

1. Press UTIL



2. Press System (F4)



3. Press Help (F3)



4. Use the scroll wheel to navigate to a help item. Press Select to choose the item.

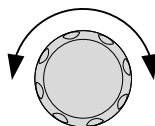

Keypad	Provides help on any front panel key that is pressed.
Create Arbitrary Waveform	Provides help on creating arbitrary waveforms.
Modulation Function	Explains how to create Modulated waveforms.

- Sweep Function Provides help on the Sweep function.
- Burst Function Provides help on the Burst function.
- DSO Link Provides help on DSO link.
- Hardcopy Explains how to use the Hardcopy function.

5. For example, select item 4 to see help on the sweep functions.

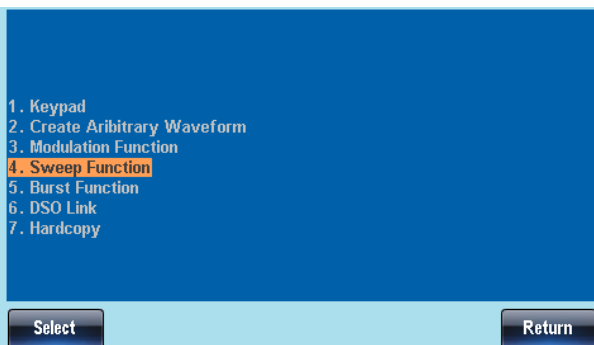

6. Use the scroll wheel to navigate the help information.

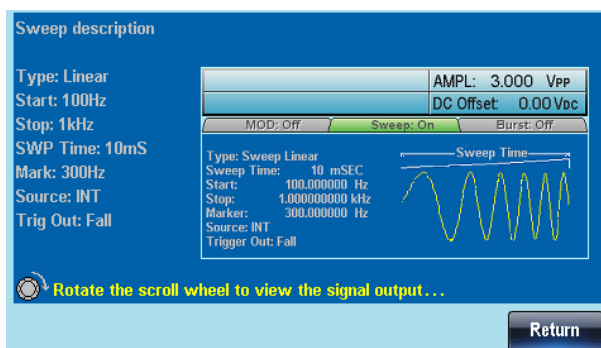

7. Press Return to return to the previous menu.

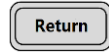

Selecting a Waveform

Square Wave

Example: Square wave, 3Vpp, 75% duty cycle, 1kHz.

Output:

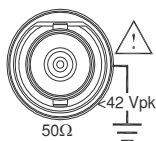

1. Press Waveform and select Square (F2).



2. Press Duty (F1), 7 + 5 + % (F5).



Input: N/A

3. Press Freq/Rate, 1 + kHz (F5).



4. Press AMPL followed by, 3 + VPP (F6).



5. Press the Output key.



Ramp Wave

Example: Ramp Wave, 5Vpp, 10kHz, 50% Symmetry.

Output:

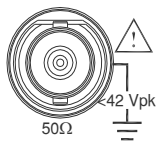

1. Press the Waveform key, and select Ramp (F5).



2. Press SYM(F1), 5 + 0 + % (F5).



Input: N/A

3. Press the Freq/Rate key then 1 + 0 + kHz (F5).



4. Press the AMPL key then 5 +VPP (F6). 

5. Press the Output key. 



Sine Wave

Example: Sine Wave, 10Vpp,100kHz

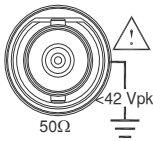
Output:

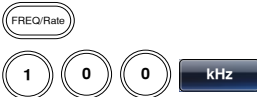

Input: N/A

1. Press the Waveform key and select Sine (F1). 
2. Press the Freq/Rate key, followed by 1 + 0 + 0 + kHz (F5). 
3. Press the AMPL key, followed by 1 + 0 + VPP (F6). 
4. Press the output key. 

Modulation

AM

Example: AM modulation. 100Hz modulating square wave. 1kHz Sine wave carrier. 80% modulation depth.

Output:

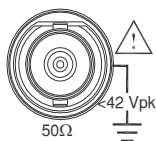

1. Press the MOD key and select AM (F1).



2. Press Waveform and select Sine (F1).



Input: N/A

3. Press the Freq/Rate key, followed by 1 + kHz (F5).



4. Press the MOD key, select AM (F1), Shape (F4), Square (F2).



5. Press the MOD key, select AM (F1), AM Freq (F3).



6. Press 1 + 0 + 0 + Hz (F2).





7. Press the MOD key, select AM (F1), Depth (F2).



8. Press 8 + 0 + % (F1).



9. Press MOD, AM (F1), Source (F1), INT (F1).
 

10. Press the Output key.
 

ASK Modulation

Example: ASK modulation. 50% duty cycle. 1kHz sine carrier wave. 10Hz rate . Internal source.

Output:

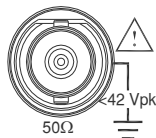



1. Press MOD and then select ASK(F2).
 

2. Press Waveform and select Sine(F1).
 

Input: N/A



3. Press the Freq/Rate key, followed by 1 + kHz (F5).
 

4. Press the MOD key, select ASK(F2), ASK Rate (F3).
 

5. Press 1 + 0 + Hz (F2)
 

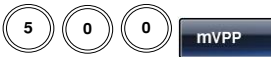
6. Press the MOD key, select ASK(F5), ASK Ampl(F2).
 

7. Press 5+0+0+mVpp(F5).
 

- Press MOD, ASK(F5), Source (F1), INT (F1).
 
- Press the Output key.
 

FM

Example: FM modulation. 100Hz modulating square wave. 1kHz Sine wave carrier. 100 Hz frequency deviation. Internal Source.

Output:

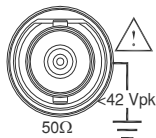



- Press the MOD key and select FM (F2).
 

- Press Waveform and select Sine (F1).
 

Input: N/A



- Press the Freq/Rate key, followed by 1 + kHz (F5).
 

- Press the MOD key, select FM (F2), Shape (F4), Square (F2).
 

- Press the MOD key, select FM (F2), FM Freq (F3).
 

- Press 1 + 0 + 0 + Hz (F2).
 

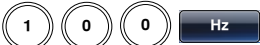
- Press the MOD key, select FM (F2), Freq Dev (F2).
 





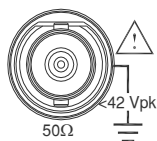

8. Press 1 + 0 + 0 + Hz (F3). 
9. Press MOD, FM (F2), Source (F1), INT (F1). 
10. Press the Output key. 

FSK Modulation



Example: FSK modulation. 100Hz Hop frequency. 1kHz Carrier wave. Sine wave. 10 Hz Rate. Internal Source.

Output:

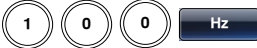

1. Press the MOD key and select FSK (F3). 
2. Press Waveform and select Sine (F1). 
3. Press the Freq/Rate key, followed by 1 + kHz (F5). 
4. Press the MOD key, select FSK (F3), FSK Rate (F5). 
5. Press 1 + 0 + Hz (F5). 
6. Press the MOD key, select FSK (F3), Hop Freq (F5). 

Input: N/A



7. Press 1 + 0 + 0 + Hz (F3). 
8. Press MOD, FSK (F3), Source (F1), INT (F1). 
9. Press the output key. 

PM Modulation



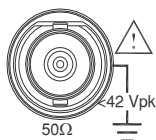

Example: PM modulation. 800Hz sinusoidal carrier wave. 15 kHz modulating sine wave. 180° phase deviation. Internal Source.





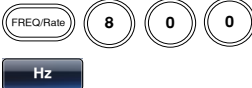





Output:



1. Press Waveform and select Sine (F1). 
2. Press the MOD key and select PM (F4). 

Input: N/A

3. Press the Freq/Rate key, followed by 8 + 0 + 0 + Hz (F4). 
4. Press the MOD key, select PM (F4), Shape (F4), Sine (F1). 
5. Press MOD, then PM (F4), PM Freq (F3). 
6. Press 1 + 5 + kHz (F3). 





7. Press MOD, PM (F4), PM Dev (F5).   
8. Press 5 + 0 + Degree (F1).   
9. Press MOD, PM (F4), Source (F1), INT (F1).   

10. Press the Output key. 

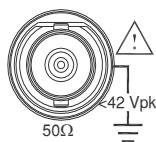
PSK Modulation













Example: PSK modulation. 50% phase deviation. 1kHz sine carrier wave. 10Hz PSK rate. Internal source.

Output





1. Press MOD and select PSK (F6).  
2. Press Waveform and select Sine(F1).  

Input: N/A

3. Press the Freq/Rate key, followed by 1 + kHz (F5).   
4. Press the MOD key, select PSK (F6), PSK Rate (F3).   
5. Press 1 + 0 + Hz (F2).   
6. Press the MOD key, select PSK (F6), PSK Phase (F2).   

7. Press 5+ 0 + % (F3) 

8. Press MOD, PSK (F6), Source (F1), INT (F1) 

9. Press the Output key 

PWM Modulation

Example: PWM modulation. 800Hz carrier, 15kHz modulated sine wave. 50% duty cycle. Internal source.

Output:

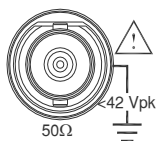

1. Press Waveform and select Square (F2) 

2. Press MOD and select PWM (F6) 





Input: N/A

3. Press the Freq/Rate key, followed by 8+0+0 Hz (F4). 

4. Press the MOD key, select PWM (F6), Shape (F4), Sine (F1). 

5. Press MOD, select PWM (F6), PWM Freq (F3) 

6. Press 1 + 5+ kHz (F3). 

7. Press MOD, select PWM(F6),Duty(F2) 
8. Press 5 + 0 + % (F1) 
9. Press MOD, PWM(F6), Source(F1),INT(F1) 
10. Press the Output key. 

SUM Modulation

Example: SUM modulation. 100Hz modulating square wave, 1kHz sinusoidal carrier wave, 50% SUM amplitude, internal source.

Output:

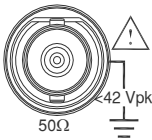



1. Press the MOD key, then SUM (F5). 

2. Press Waveform, and select Sine (F1). 

Input: N/A

3. Press Freq/Rate followed by 1 + kHz (F5). 

4. Press the MOD key, SUM (F5), Shape (F4), Square (F2). 

5. Press the MOD key and select SUM (F5), SUM Freq (F3). 

6. Press 1 + 0 + 0 + Hz (F2).



7. Press the MOD key and select SUM (F5), SUM Ampl (F2).



8. Press 5 + 0 + % (F1).



9. Press MOD, SUM (F5), Source (F1), INT (F1).



10. Press the Output key.



Sweep

Example: Frequency Sweep. Start Frequency 10mHz, Stop frequency 1MHz. Log sweep, 1 second sweep, Marker Frequency 550 Hz, Manual Trigger.

Output:

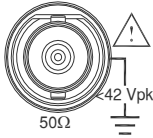

1. Press Sweep, Start (F3).



2. Press 1 + 0 + mHz (F2).



3. Press Sweep, Stop (F4).



Input: N/A

4. Press 1 + MHz (F5).



5. Press Sweep, Type (F2), Log (F2).



6. Press Sweep, SWP Time (F5).



7. Press 1 + SEC (F2).



8. Press Sweep, More (F6), Marker (F3), ON/OFF (F2), Freq (F1).



9. Press 5 + 5 + 0 + Hz (F3).



10. Press the Output key.



11. Press Sweep, Source (F1), Manual (F3), Trigger (F1).



Burst

Example: Burst Mode, N-Cycle (Internally triggered), 1kHz burst frequency, Burst count = 5, 10 ms Burst period, 0° burst phase, Internal trigger, 10 us delay, rising edge trigger out

Output:

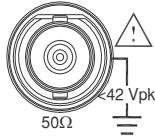

1. Press **FREQ/Rate** 1 kHz (F5).
2. Press **Burst**, **N Cycle** (F1), **Cycles** (F1).

Input: N/A

3. Press **5** + **Cyc** (F5).
4. Press **Burst**, **N Cycle** (F1), **Period** (F4).
5. Press **1** + **0** + **mSEC** (F2).
6. Press **Burst**, **N Cycle** (F1), **Phase** (F3).
7. Press **0** + **Degree** (F5).
8. Press **Burst**, **N Cycle** (F1), **TRIG set** (F5), **INT** (F1).
9. Press **Burst**, **N Cycle** (F1), **TRIG set** (F5), **Delay** (F4).
10. Press **1** + **0** + **uSEC** (F2).

11. Press Burst, N Cycle (F1), TRIG setup (F5), TRIG out (F5), ON/OFF (F3), Rise (F1).



12. Press the Output key.



ARB

ARB—Add Built-In Waveform

Example: ARB Mode, Exponential Rise. Start 0, Length 100, Scale 327.

Output:

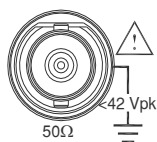

1. Press ARB, Built in (F3), Wave (F4), Math(F2), use the scroll wheel to select Exporise and then press Select(F5).



2. Press Start (F1), 0 + Enter (F2), Return.

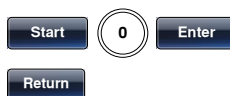

3. Press Length (F2), 100, Enter (F2), Return.



4. Press Scale (F3), 327, Enter (F2), Return, Done (F5).



ARB—Add Point

Example: ARB Mode, Add point, Address 40, data 300.

Output:

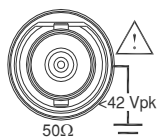

1. Press ARB, Edit (F2), Point (F1), Address (F1).



2. Press 4 + 0 + Enter (F5), Return.



3. Press Data (F2),
3+0+0, Enter (F5).



ARB-Add Line

Example: ARB Mode, Add line, Address:Data (10:30, 50:100)

Output:

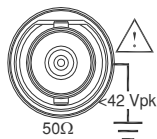

1. Press ARB, Edit (F2), Line (F2), Start ADD (F1).



2. Press 1 + 0 + Enter (F5), Return.



3. Press Start Data (F2), 3 + 0, Enter (F5), Return.



4. Press Stop ADD (F3), 5 + 0, Enter (F5), Return.



5. Press Stop Data (F4), 1 + 0 + 0, Enter (F5), Return, Done (F5).



ARB-Output Section

Example: ARB Mode, Output ARB Waveform, Start 0, Length 1000.

Output:

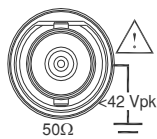

1. Press ARB, Output (F6).



2. Press Start (F1), 0 + Enter (F5), Return.

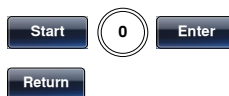

- Press Length (F2), 1 + 0 + 0, Enter (F5), Return.



ARB–Output N Cycle

Example: ARB Mode, Output N Cycle, Start 0, Length 1000, N Cycle 10.

Output:

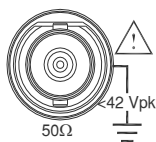

- Press ARB, Output(F6).
- Press Start(F1), 0+Enter (F5), Return(F6).
- Press Length(F5), 1+0+0, Enter(F5), Return(F6).
- Press N Cycle (F4).
- Press Cycle(F1), 1+0.
- Press Trigger(F5) to trigger the output once.



ARB–Output Infinite Cycles

Example: ARB Mode, output N cycle, start 0, length 1000, cycles infinite.

Output:

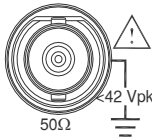

1. Press ARB, Output(F6).



2. Press Start (F1), 0 + Enter (F5), Return(F6).

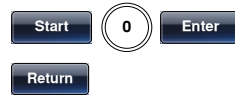

3. Press Length (F2), 1+0+0+0, Enter (F5), Return (F6).



4. Press Infinite(F5), Return(F6).



ARB–Output Marker

Example: ARB mode, output marker, Start 30, Length.

Output:

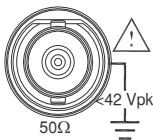

1. Press ARB, Output (F6), Marker (F3).



2. Press Start (F1), 3+0, Enter (F5), Return.





3. Press Length (F2), 8 + 0, Enter (F5), Return.



Utility Menu



Save

Example: Save to Memory file #5.

1. Press UTIL, Memory (F1), Store (F1).

2. Choose a setting using the scroll wheel and press Done (F5).

Recall

Example: Recall Memory file #5.

1. Press UTIL, Memory (F1), Recall (F2).

2. Choose a setting using the scroll wheel and press Done (F5).

Menu Tree

Conventions Use the menu trees as a handy reference for the function generator functions and properties. The MFG-2000 menu system is arranged in a hierarchical tree. Each hierarchical level can be navigated with the operation or soft menu keys. Pressing the Return key will return you to the previous menu level.

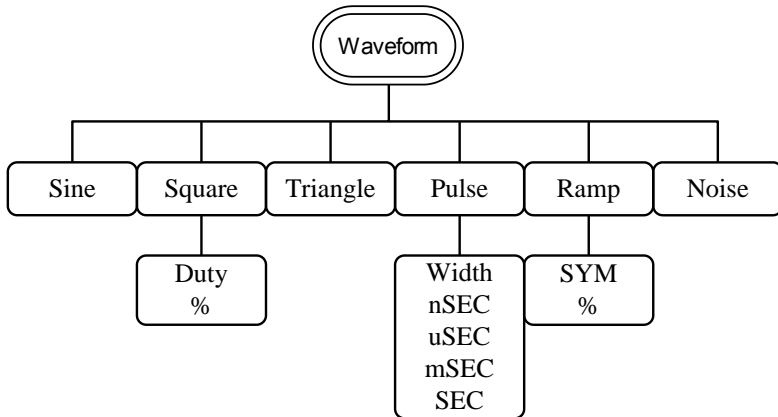
Waveform



ARB-Display

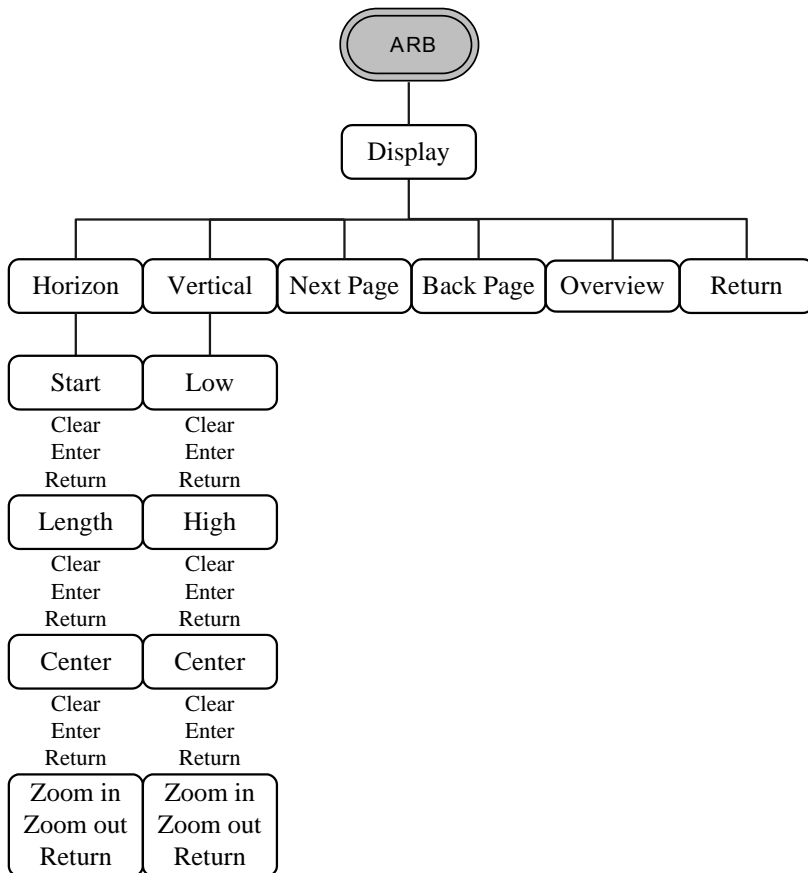

ARB-Edit

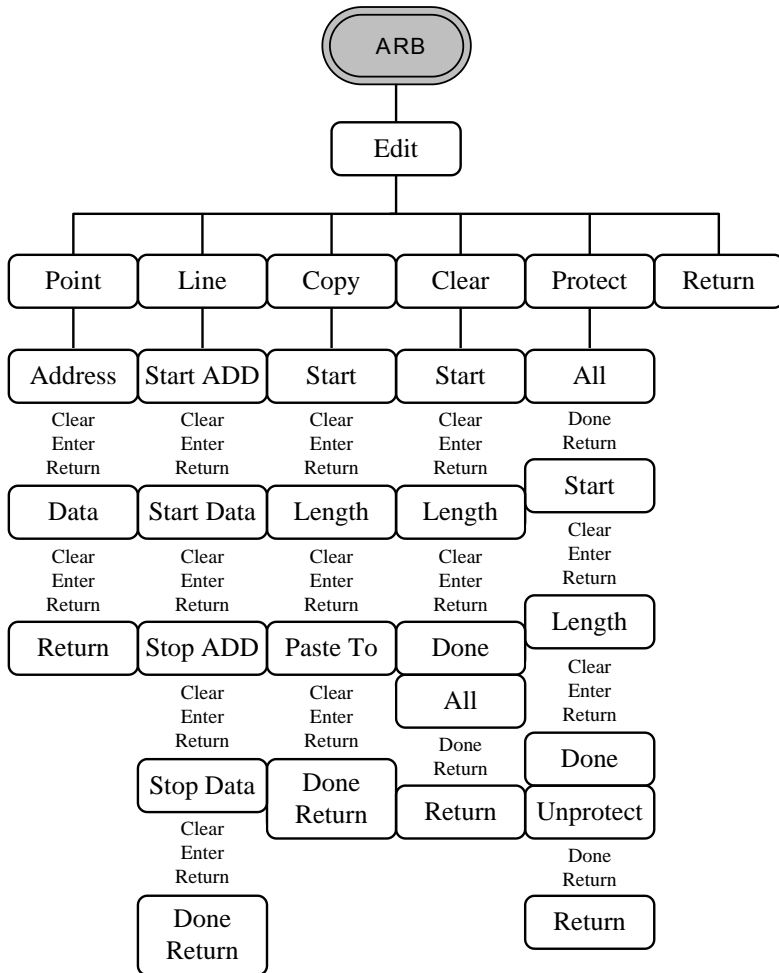

ARB-Built In

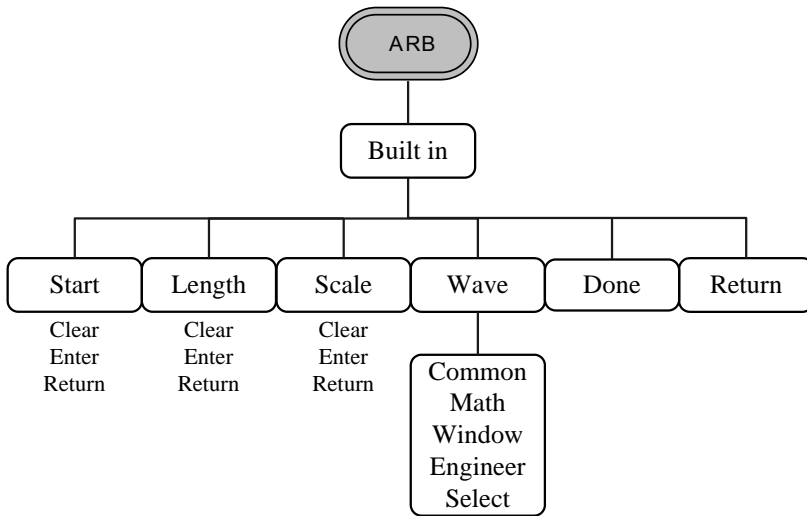

ARB-Save

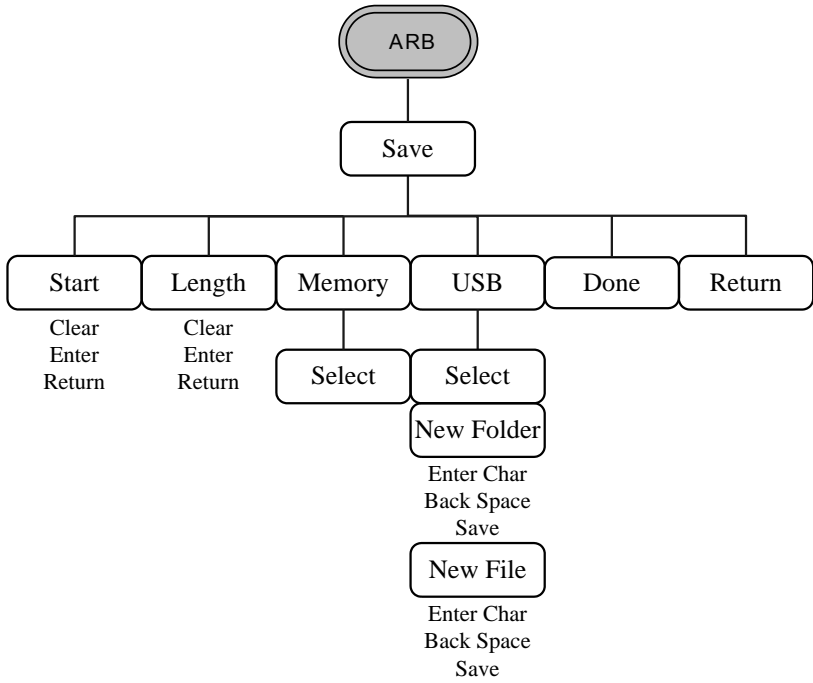

ARB-Load

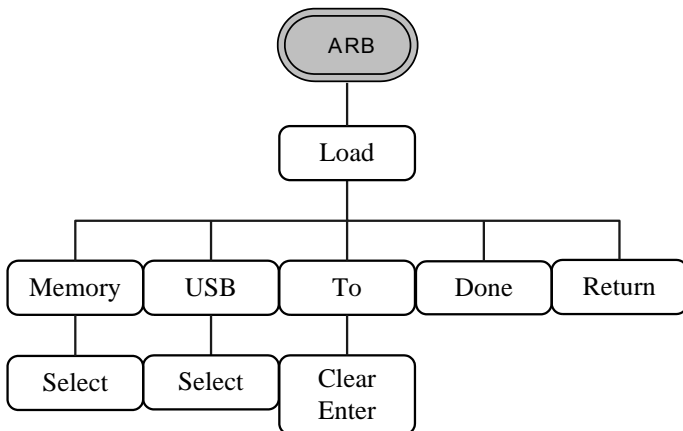

ARB-Output

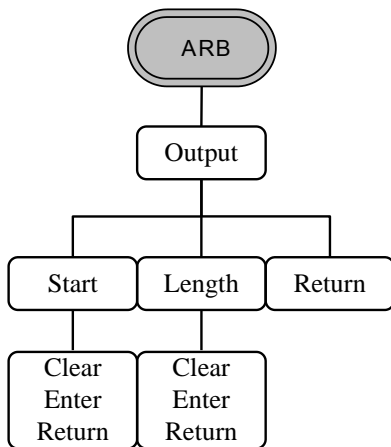

MOD

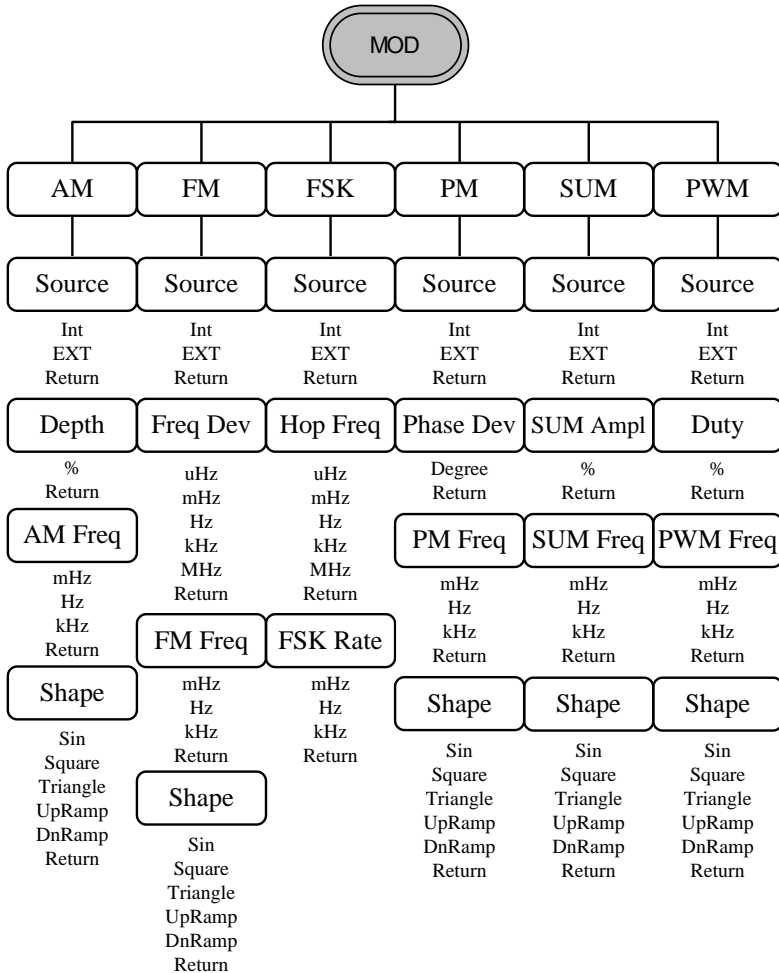

SWEEP

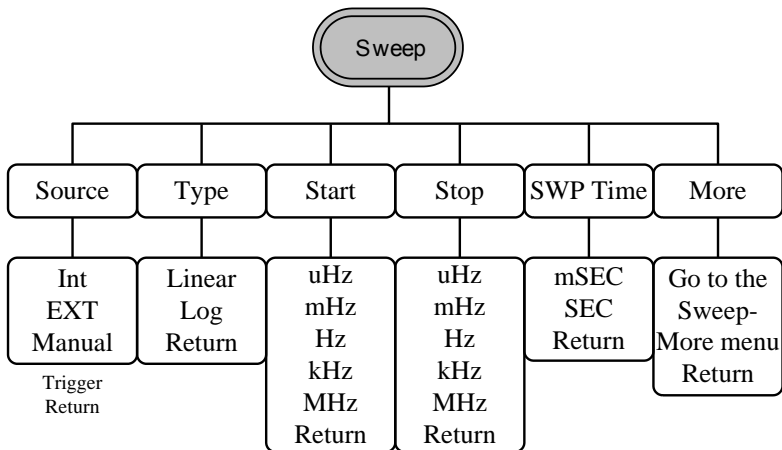

SWEEP- More

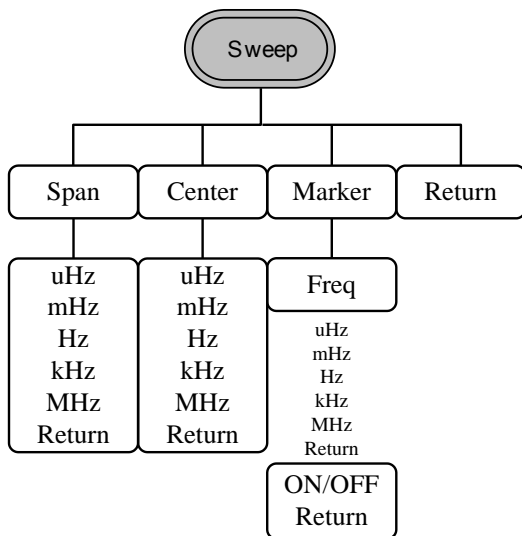

Burst-N Cycle

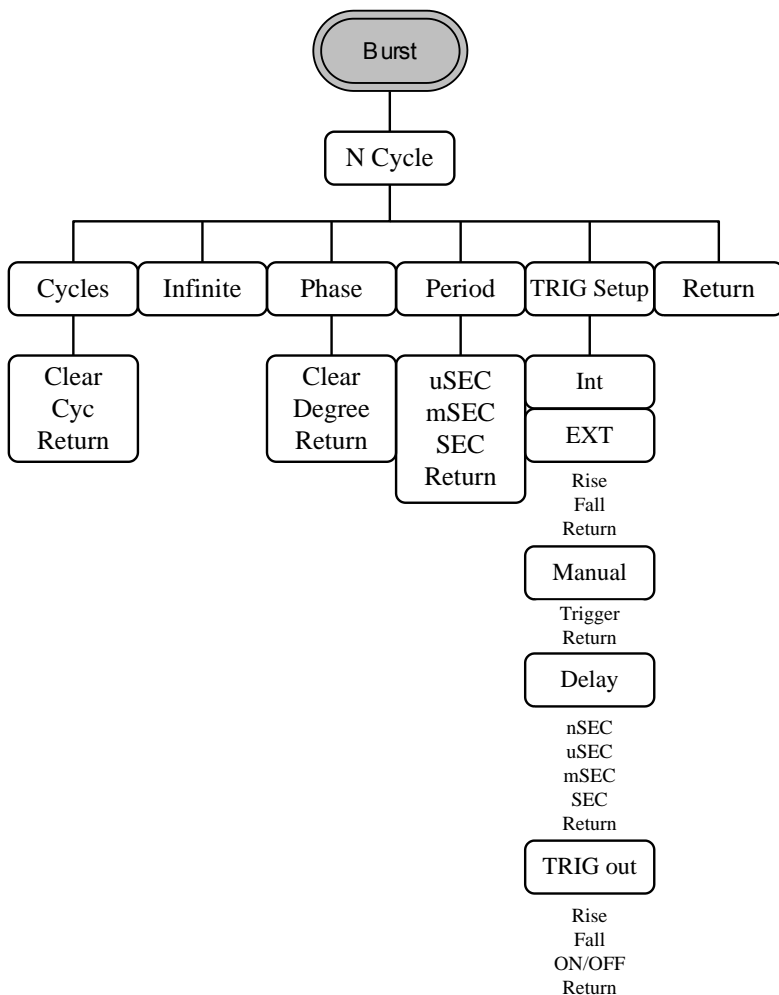

Burst-Gate

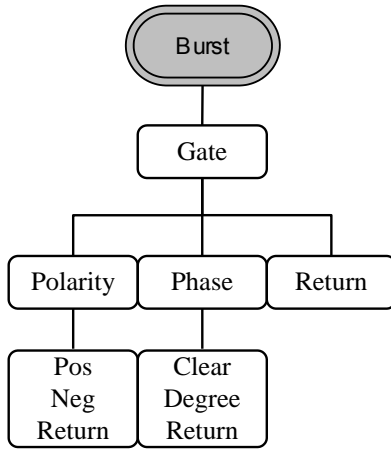

UTIL

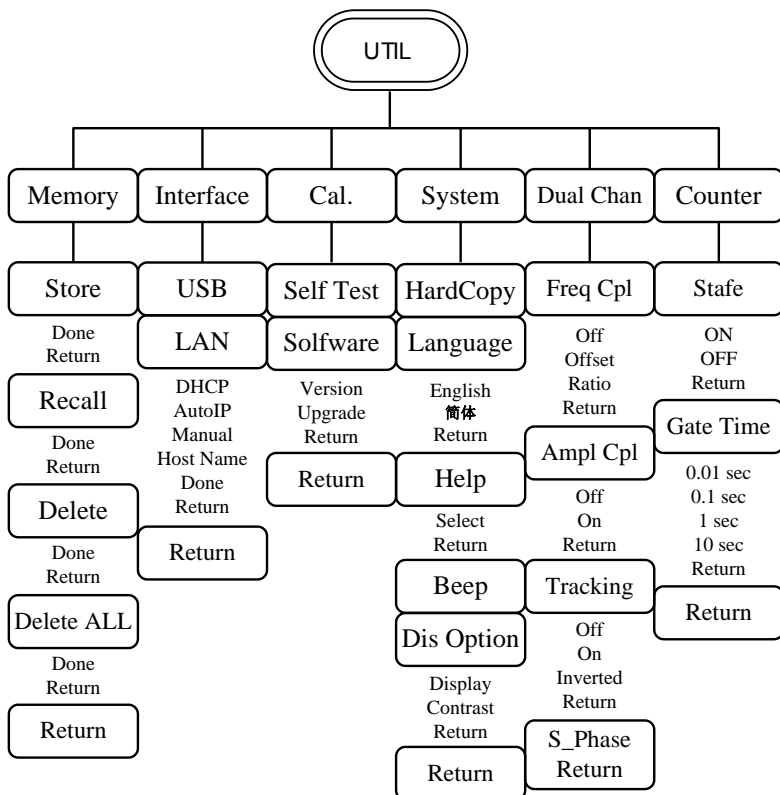

CH1/CH2

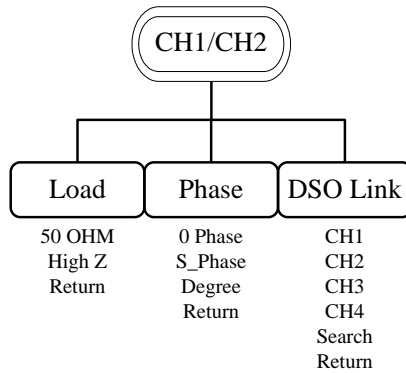

CH3/RF

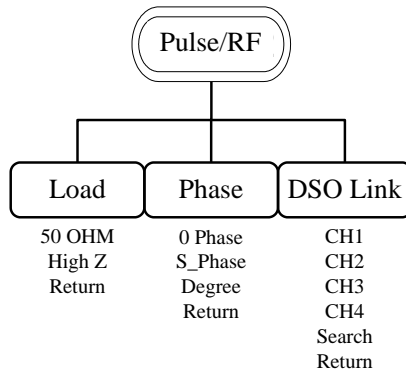

Default Settings

The Preset key is used to restore the default panel settings.



Output Settings	Function	Sine Wave
	Frequency	1kHz
	Amplitude	3.000 Vpp
	Offset	0.00V dc
	Output units	Vpp
	Output terminal	50Ω
Modulation		
(AM/ASK/FM/FSK/PM/PSK/SUM)		
	Carrier wave	1kHz sine wave
	Modulation wave	100Hz sine wave
	AM depth	100%
	ASK amplitude	500mVpp
	ASK frequency	10Hz
	FM deviation	100Hz
	FSK hop frequency	100Hz
	FSK frequency	10Hz
	PM phase deviation	180°
	PSK phase	180°
	PSK frequency	10Hz
	SUM amplitude	50%
	Modem status	Off
PWM Modulation		
	Carrier wave	1kHz Square wave
	Modulation wave	20kHz sine wave

	PWM duty cycle	50%
	Modem status	Off
Sweep	Start/Stop frequency	100Hz/1kHz
	Sweep time	1ms
	Sweep type	Linear
	Sweep status	Off
Burst	Burst frequency	1kHz
	Ncycle	1
	Burst period	10ms
	Burst starting phase	0°
	Burst status	Off
System Settings	Power off signal	On
	Display mode	On
	Error queue	Cleared
	Memory settings	No change
	Output	Off
Trigger	Trigger source	Internal (immediate)
Calibration	Calibration Menu	Restricted

MFG-2000 Series Specifications

The specifications apply when the function generator is powered on for at least 30 minutes under +18°C~+28°C.

MFG-2000 series specific functions						
	CH1	CH2	25MHz Pulse Generator	RF Generator (function with ARB)	Power Amplifier	Modulation /Sweep/Burst/Frequency Counter
	Function With 200MSa/sARB	Function With 200MSa/sARB				
MFG-2110	●10MHZ		●			
MFG-2120	●20MHZ		●			
MFG-2120MA	●20MHZ		●		●	●
MFG-2130M	●30MHZ		●			●
MFG-2160MF	●60MHZ		●	●160MHZ		●
MFG-2160MR	●60MHZ		●	●320MHZ		●
MFG-2230M	●30MHZ	●30MHZ	●			●
MFG-2260M	●60MHZ	●60MHZ	●			●
MFG-2260MFA	●60MHZ	●60MHZ	●	●160MHZ	●	●
MFG-2260MRA	●60MHZ	●60MHZ	●	●320MHZ	●	●

Arbitrary Functions

ARB function	Built-in
Sample Rate	200 MSa/s
Repetition Rate	100MHz
Waveform Length	16k points
Amplitude	14 bits
Resolution	
Non-Volatile	10sets 16k points(1)
Memory	
User-defined output section	From point 2~16384 (optional)
User-defined output marker section	From point 2 ~ 16384(optional)
Output mode	1~1048575 cycles or infinite mode

Frequency Characteristics

Range	Sine	320MHz(max)
	Square	25MHz(max)
	Triangle, Ramp	1MHz
Resolution		1μHz
Accuracy	Stability	±20 ppm
	Aging	±1 ppm, per 1 year
	Tolerance	≤1μHz

Output Characteristics(2)

Amplitude	Range	1mVpp to 10 Vpp (into 50Ω) 2mVpp to 20 Vpp (open-circuit)
	Accuracy	±2% of setting ±1 mVpp (at 1 kHz/into 50Ω without DC offset)

	Resolution	0.1mV or 4 digits
	Flatness	± 1% (0.1dB) ≤ 1MHz ± 3% (0.3dB) ≤ 50 MHz ± 10% (0.9dB) ≤ 160MHz ± 30% (3dB) ≤ 320MHz (sinewave relative to 1 kHz/into 50Ω)
	Units	Vpp, Vrms, dBm
Offset	Range	±5 Vpk ac +dc (into 50Ω) ±10Vpk ac +dc (Open circuit)
	Accuracy	1% of setting + 5mV+ 0.5% of amplitude
Waveform Output	Impedance	50Ω typical (fixed) > 10MΩ (output disabled)
	Protection	Short-circuit protected Overload relay automatically disables main output
	Ground Isolation	42Vpk max
Sync Output	Range	TTL-compatible into>1kΩ
	Impedance	50Ω standard
	Ground Isolation	42Vpk max
Sine wave Characteristics(3)		
	Harmonic distortion	-60 dBc DC~200kHz, Ampl>0.1 Vpp -55 dBc 200kHz~1 MHz, Ampl>0.1 Vpp -45 dBc 1MHz~10 MHz, Ampl>0.1Vpp -30 dBc 10MHz~320MHz, Ampl>0.1Vpp
	Total harmonic distortion	< 0.1% (Ampl>1Vpp) DC~100 kHz
Square wave Characteristics		
	Rise/Fall Time	<15ns
	Overshoot	<5%
	Asymmetry	1% of period +5 ns
	Variable duty Cycle	0.01% to 99.99%(limited by the current frequency setting)
	Jitter	20ppm+500ps(4)
Ramp Characteristics		
	Linearity	< 0.1% of peak output
	Variable Symmetry	0% to 100%
Pulse Characteristics		
	Frequency	1uHz~25MHz
	Pulse Width	≥ 20nS(limited by the current frequency setting)
	Variable duty Cycle	0.01%~99.99%(limited by the current frequency setting)
	Overshoot	<5%
	Jitter	20ppm +500ps(4)
AM Modulation		
	Carrier Waveforms	Sine, Square, Triangle, Ramp, Pulse, Arb
	Modulating Waveforms	Sine, Square, Triangle, Upramp, Dnramp

	Modulating Frequency	2mHz to 20kHz (Int) DC to 20kHz (Ext)
	Depth	0% to 120.0%
	Source	Internal / External
FM Modulation		
	Carrier Waveforms	Sine, Square, Triangle, Ramp
	Modulating Waveforms	Sine, Square, Triangle, Upramp, Dnramp
	Modulating Frequency	2mHz to 20kHz (Int) DC to 20kHz (Ext)
	Peak Deviation	DC to max frequency
	Source	Internal / External
PM		
	Carrier Waveforms	Sine, Square, Triangle, Ramp
	Modulating Waveforms	Sine, Square, Triangle, Upramp, Dnramp
	Modulation Frequency	2mHz to 20kHz (Int) DC to 20kHz (Ext)
	Phase deviation	0°~360.0°
	Source	Internal / External
SUM		
	Carrier Waveforms	Sine, Square, Triangle, Ramp
	Modulating Waveforms	Sine, Square, Triangle, Upramp, Dnramp
	Modulation Frequency	2mHz to 20kHz (Int) DC to 20kHz (Ext)
	SUM depth	0%~100.0%
	Source	Internal / External
PWM		
	Carrier Waveforms	Sine, Square, Triangle, Ramp
	Modulating Waveforms	Sine, Square, Triangle, Upramp, Dnramp
	Modulation Frequency	2mHz to 20kHz (Int) DC to 20kHz (Ext)
	Phase deviation	0%~100.0% pulse width
	Source	Internal / External
FSK		
	Carrier Waveforms	Sine, Square, Triangle, Ramp, Pulse
	Modulating Waveforms	50% duty cycle square
	Internal Frequency	2 mHz to 1 MHz
	Frequency Range	1μHz to max frequency
	Source	Internal / External
Sweep		
	Waveforms	Sine, Square, Triangle, Ramp
	Type	Linear or Logarithmic
	Sweep direction	Sweep up or sweep down
	Start/Stop Freq	1uHz to max frequency
	Sweep Time	1ms to 500s
	Source	Internal / External
	Trigger	Single, External, Internal.

	Marker Source	Marker signal on falling edge (programmable) Internal / External
Burst		
	Waveforms	Sine, Square, Triangle, Ramp
	Frequency	1uHz~Max Frequency
	Pulse count	1~1000000 Cycles or infinite
	Start/ Stop Phase	-360.0°~+360.0°
	Internal Frequency	1 us~500 s
	Gate source	External Trigger
	Trigger Source	Single, External, Internal.
Trigger Delay		
	NCycle, Infinite	0s~100 s
External Trigger Input		
	Type	For FSK, Burst, Sweep
	Input Level	TTL Compatibility
	Slope	Rising or Falling(Selectable)
	Pulse Width	>100ns
	Input Impedance	10kΩ, DC coupled
External Modulation Input		
	Type	For AM, FM, PM,SUM,PWM
	Voltage Range	±5V full scale
	Input Impedance	10kΩ
	Frequency	DC to 20kHz
	Ground Isolation	42Vpk max
Trigger Output		
	Type	For FSK,Burst, Sweep
	Level	TTL Compatible into 50Ω
	Pulse Width	>450ns
	Maximum Rate	1MHz
	Fan-out	≥4 TTL Load
	Impedance	50Ω Typical
Dual Channel Function(CH1/CH2)		
	Phase	-180° ~180° Synchronize phase
	Track	CH2=CH1
	Coupling	Frequency(Ratio or Difference) Amplitude & DC Offset
	Dsolink	√
Pulse Generator		
	Amplitude	1mVpp to 2.5 Vpp (into 50Ω) 2mVpp to 5 Vpp (open-circuit)
	Offset	±1 Vpk ac +dc (into 50Ω) ±2Vpk ac +dc (Open circuit)
	Frequency	1uHz~25MHz
	Pulse Width	20nS~999.9ks(limited by the current frequency setting)
	Variable duty Cycle	0.01%~99.99%(limited by the current frequency setting)
	Leading and Trailing Edge Time(5)	10nS~ 20S(1ns resolution) (limited by the current frequency and pulse width settings)
	Overshoot	<5%
	Jitter	100ppm +500ps(4)

Frequency Counter		
Range	5Hz to 150MHz	
Accuracy	Time Base accuracy±1count	
Time Base	±20ppm (23 °C ±5 °C)	
Resolution	The maximum resolution is: 100nHz for 1Hz, 0.1Hz for 100MHz.	
Input Impedance	1kΩ/1pf	
Sensitivity	35mVrms ~ 30Vms (5Hz to 150MHz)	
Ground Isolation	42Vpk max	
RF Generator		
Waveforms	Sine, Square, Ramp, Pulse, Noise, ARB	
Amplitude	1mVpp to 2 Vpp (MFG-2XXXMF)	
(into 50Ω)	1mVpp to 1 Vpp (MFG-2XXXMR)	
Offset	±1 Vpk ac +dc (into 50Ω) ±2Vpk ac +dc (Open circuit)	
Frequency	1uHz~160MHz(MFG-2XXXMF) 1uHz~320MHz(MFG-2XXXMR)	
Modulatin/Sweep		
Modulation Type	AM,FM,PM,FSK,PWM(The detail same as CH1 modulation specification)	
Sweep type	Frequency	
Source	INT/EXT (INT only forAM,FM,PM, PWM)	
ASK		
Carrier Waveforms	Sine, Square, Triangle, Ramp,Pulse	
Modulating Waveforms	50% duty cycle square	
Internal Frequency	2mHz to 1 MHz	
Amplitude Range	1mvpp~max amplitude	
Source	Internal / External	
PSK		
Carrier Waveforms	Sine, Square, Triangle, Ramp,Pulse	
Modulating Waveforms	50% duty cycle square	
Internal Frequency	2mHz to 1 MHz	
Phase Range	0°~360.0°	
Source	Internal / External	
ARB function		
Sample Rate	200 MSa/s	
Waveform Length	16k points	
Amplitude	14 bits	
Resolution		
User-defined output section	From point 2~16384 (optional)	
Jitter	20ppm +5ns	
Power Amplifier		
Input Impedance	10K Ω	
Input voltage	1.25Vpmax	
Working Mode	Constant Voltage	
Gain	20dB	
Output Power	20W(Square)	
(RL=8 Ω)		

Output Voltage	12.5Vpmax
Output Current	1.6Amax
Rise/Fall Time	<2.5uS
Full Power	DC-100KHz
Bandwidth	
Overshoot	5%
Total harmonic distortion	< 0.1% (Ampl>1Vpp) 20Hz~20 kHz
Ground Isolation	42Vpk max
Save/Recall	10 Groups of Setting Memories
Interface	LAN(MFG-22XX ONLY), USB
Display	4.3" TFT LCD 480 × 3 (RGB) × 272
General Specifications	
Power Source	AC100~240V, 50~60Hz or AC100~120V, AC220~240V, 50~60Hz
Power Consumption	30W or 80W(With power amplifier)
Operating Environment	Temperature to satisfy the specification : 18 ~ 28 °C Operating temperature : 0 ~ 40 °C Relative Humidity: ≤ 80%, 0 ~ 40 °C ≤ 70%, 35 ~ 40 °C Installation category : CAT II
Operating Altitude	2000 Meters
Pollution Degree	IEC 61010 degree 2, Indoor use
Storage Temperature	-10~70 °C, Humidity: ≤70%
Dimensions (WxHxD)	266(W) x 107(H) x 293(D) mm
Weight	Approx. 2.5kg or 4kg(With power amplifier)
Safety designed to	EN61010-1
Accessories	GTL-101× 1(MFG-21XX) GTL-101× 2(MFG-22XX) Quick Start Guide ×1 CD (user manual + software) ×1 Power cord×1

- (1). A total of ten waveforms can be stored. (Every waveform can be composed of a maximum of 16k points.)
- (2). Add 1/10th of output amplitude and offset specification per °C for operation outside of 0°C to 28°C range (1-year specification).
- (3). DC offset set to zero,
- (4). Jitter specification for RF channel: 20ppm +5ns.
- (5).Only Pluse channel support

EC Declaration of Conformity

We

GOOD WILL INSTRUMENT CO., LTD.

No.7-1, Jhongsing Rd., Tucheng Dist., New Taipei City 236, Taiwan

GOOD WILL INSTRUMENT (SUZHOU) CO., LTD.

No. 69, Lushan Road, Suzhou New District Jiangsu, China

declares that the below mentioned product
MFG-2110, MFG-2120, MFG-2120MA, MFG-2130M, MFG-2230M, MFG-2260M, MFG-2160MF, MFG-2260MFA, MFG-2160MR, MFG-2260MRA
 Are here with confirmed to comply with the requirements set out in the Council Directive on the Approximation of the Law of Member States relating to Electromagnetic Compatibility (2004/108/EC&2014/30/EU) and Low Voltage Equipment Directive (2006/95/EC&2014/30/EU). For the evaluation regarding the Electromagnetic Compatibility and Low Voltage Equipment Directive, the following standards were applied:

© EMC

EN 61326-1:	Electrical equipment for measurement, control and laboratory use — EMC requirements (2006)	
EN 61326-2-1:		
Conducted and Radiated Emissions EN 55011: 2009+A1:2010(Class A)	Electrostatic Discharge EN 61000-4-2: 2009	
Current Harmonic EN 61000-3-2: 2014	Radiated Immunity EN 61000-4-3: 2006+A1 : 2008+A2:2010	
Voltage Fluctuation EN 61000-3-3: 2013	Electrical Fast Transients IEC 61000-4-4: 2012	
-----	Surge Immunity EN 61000-4-5: 2006	
-----	Conducted Susceptibility EN 61000-4-6: 2014	
-----	Power Frequency Magnetic Field EN 61000-4-8: 2010	
-----	Voltage Dips/ Interrupts IEC 61000-4-11: 2004	

© Safety

Low Voltage Equipment Directive 2006/95/EC&2014/30/EU
Safety Requirements IEC/EN 61010-1: 2010(Third Edition)