

# Multi-Channel Function Generator

MFG-2220HM

---

## QUICK START GUIDE

GW INSTEK PART NO. 82MF-222HMM01



ISO-9001 CERTIFIED MANUFACTURER

**GW INSTEK**

This manual contains proprietary information, which is protected by copyright. All rights are reserved. No part of this manual may be photocopied, reproduced or translated to another language without prior written consent of Good Will Corporation.

The information in this manual was correct at the time of printing. However, Good Will continues to improve its products and therefore reserves the right to change the specifications, equipment, and maintenance procedures at any time without notice.

**Good Will Instrument Co., Ltd.**  
No. 7-1, Jhongsing Rd., Tucheng Dist., New Taipei City 236, Taiwan.

# Table of Contents

<b>S</b> AFETY INSTRUCTIONS.....	4
<b>G</b> ETTING STARTED .....	9
Main Features .....	9
Panel Overview.....	11
Setting Up the function Generator.....	17
<b>Q</b> UICK REFERENCE .....	19
How to use the Digital Inputs .....	21
How to use the Help Menu .....	22
Selecting a Waveform .....	25
Modulation.....	28
Sweep.....	39
Burst .....	41
ARB .....	43
Utility Menu .....	46
Menu Tree .....	47
Default Settings .....	65
MFG-2220HM Series Specifications .....	67
EC Declaration of Conformity .....	74
GLOBL HEADQAQRTERS.....	75

# S SAFETY INSTRUCTIONS

This chapter contains important safety instructions that should be followed when operating and storing the function generator. Read the following before any operation to ensure your safety and to keep the function generator in the best condition.

## Safety Symbols

These safety symbols may appear in this manual or on the instrument.

---



WARNING

Warning: Identifies conditions or practices that could result in injury or loss of life.



CAUTION

Caution: Identifies conditions or practices that could result in damage to the function generator or to other objects or property.



DANGER High Voltage



Attention: Refer to the Manual



Protective Conductor Terminal



Earth (Ground) Terminal



DANGER Hot Surface



Double Insulated



Do not dispose electronic equipment as unsorted municipal waste. Please use a separate collection facility or contact the supplier from which this instrument was purchased.

## Safety Guidelines

---

General Guideline • Do not place heavy objects on the instrument.





CAUTION

- Do not place flammable objects on the instrument.
- Avoid severe impact or rough handling that may damage the function generator.
- Avoid discharges of static electricity on or near the function generator.
- Use only mating connectors, not bare wires, for the terminals.
- The instrument should only be disassembled by a qualified technician.

(Measurement categories) EN 61010-1:2010 (Third Edition) specifies the measurement categories and their requirements as follows. The MFG-2220HM falls under category II.

- Measurement category IV is for measurement performed at the source of a low-voltage installation.
  - Measurement category III is for measurement performed in a building installation.
  - Measurement category II is for measurement performed on circuits directly connected to a low voltage installation.
  - Measurement category I is for measurements performed on circuits not directly connected to Mains.
-

- Power Supply
- AC Input voltage: 100 ~ 240V AC, 50 ~ 60Hz.
-  **WARNING**
- Connect the protective grounding conductor of the AC power cord to an earth ground to prevent electric shock.

- Fuse
- Fuse type: T0.5A/250V
-  **WARNING**
- Only qualified technicians should replace the fuse.
  - To ensure fire protection, replace the fuse only with the specified type and rating.
  - Disconnect the power cord and all test leads before replacing the fuse.
  - Make sure the cause of fuse blowout is fixed before replacing the fuse.

- Cleaning the function generator
- Disconnect the power cord before cleaning the function generator.
  - Use a soft cloth dampened in a solution of mild detergent and water. Do not spray any liquid into the function generator.
  - Do not use chemicals containing harsh products such as benzene, toluene, xylene, and acetone.

- Operation Environment
- Location: Indoor, no direct sunlight, dust free, almost non-conductive pollution (Note below) and avoid strong magnetic fields.
  - Relative Humidity: < 80%
  - Altitude: < 2000m
  - Temperature: 0°C to 40°C

(Pollution Degree) EN 61010-1:2010(Third Edition) specifies pollution degrees and their requirements as follows. The function generator falls under degree 2.

Pollution refers to “addition of foreign matter, solid, liquid, or gaseous (ionized gases), that may produce a reduction of dielectric strength or surface resistivity”.

- Pollution degree 1: No pollution or only dry, non-conductive pollution occurs. The pollution has no influence.
- Pollution degree 2: Normally only non-conductive pollution occurs. Occasionally, however, a temporary conductivity caused by condensation must be expected.
- Pollution degree 3: Conductive pollution occurs, or dry, non-conductive pollution occurs which becomes conductive due to condensation which is expected. In such conditions, equipment is normally protected against exposure to direct sunlight, precipitation, and full wind pressure, but neither temperature nor humidity is controlled.

---

Storage environment

- Location: Indoor
- Relative Humidity: < 70%
- Temperature: -10°C to 70°C

---

Disposal



Do not dispose this instrument as unsorted municipal waste. Please use a separate collection facility or contact the supplier from which this instrument was purchased. Please make sure discarded electrical waste is properly recycled to reduce environmental impact.

## Power cord for the United Kingdom

When using the function generator in the United Kingdom, make sure the power cord meets the following safety instructions.

NOTE: This lead/appliance must only be wired by competent persons



**WARNING: THIS APPLIANCE MUST BE EARTHED**

IMPORTANT: The wires in this lead are coloured in accordance with the following code:

Green/ Yellow:	Earth
Blue:	Neutral
Brown:	Live (Phase)



As the colours of the wires in main leads may not correspond with the coloured marking identified in your plug/ appliance, proceed as follows:

The wire which is coloured Green & Yellow must be connected to the Earth terminal marked with either the letter E, the earth symbol  $\oplus$  or coloured Green/Green & Yellow.

The wire which is coloured Blue must be connected to the terminal which is marked with the letter N or coloured Blue or Black.

The wire which is coloured Brown must be connected to the terminal marked with the letter L or P or coloured Brown or Red.

If in doubt, consult the instructions provided with the equipment or contact the supplier.

This cable/appliance should be protected by a suitably rated and approved HBC mains fuse: refer to the rating information on the equipment and/or user instructions for details. As a guide, a cable of 0.75mm<sup>2</sup> should be protected by a 3A or 5A fuse. Larger conductors would normally require 13A types, depending on the connection method used.

Any exposed wiring from a cable, plug or connection that is engaged in a live socket is extremely hazardous. If a cable or plug is deemed hazardous, turn off the mains power and remove the cable, any fuses and fuse assemblies. All hazardous wiring must be immediately destroyed and replaced in accordance to the above standard.



# G GETTING STARTED

The Getting started chapter introduces the function generator's main features, appearance, set up procedure and power-up.

## Main Features

---

- |             |  |
|-------------|--|
| Performance | <ul style="list-style-type: none"><li>• DDS Function Generator series</li><li>• 1<math>\mu</math>Hz high frequency resolution maintained at full range</li><li>• 20ppm frequency stability</li><li>• Arbitrary Waveform Capability</li><li>• 500 MSa/s sample rate</li><li>• 125 MSa/s repetition rate</li><li>• 16k-point waveform length</li><li>• 10 groups of 16k waveform memories</li><li>• True waveform output to display</li><li>• User-defined output section</li><li>• DWR (Direct Waveform Reconstruction) capability</li><li>• Ability to edit waveforms without a PC</li><li>• -60dBc low distortion sine wave</li></ul> |
| Features    | <ul style="list-style-type: none"><li>• Sine, Square, Ramp, Pulse, Noise, Harmonic, DC waveforms</li><li>• Internal and external LIN/LOG sweep with marker output</li><li>• Int/Ext AM, ASK, FM, FSK, PM, PSK, SUM, PWM</li></ul>  |
-

modulation

- Burst function with internal and external triggers
  - Pulse waveform with configurable rise times & fall times
  - Store/recall 10 groups of setting memories
  - Output overload protection
- 

Interface



- USB interface as standard, LAN interface
- 4.3 inch Color TFT LCD (480 X 272) graphical user interface
- AWES (Arbitrary Waveform Editing Software) PC software

## Panel Overview

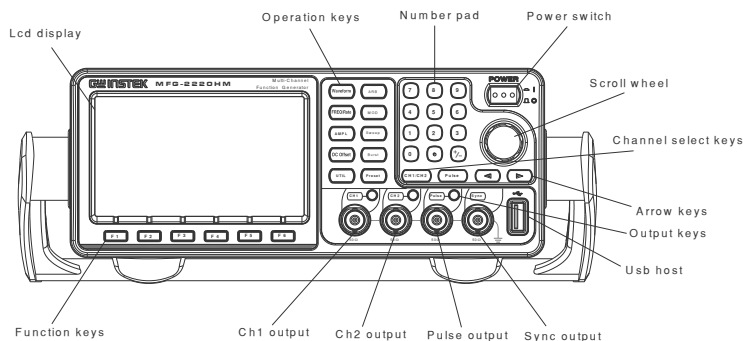
### MFG-2220HM Front Panel

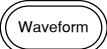
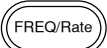

LCD Display TFT color display, 480 x 272 resolution.

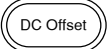
Function Keys F1~F6		Activates functions that appear on the bottom of the LCD screen.
Operation Keys		The waveform key is used to select a type of waveform.
		The FREQ/Rate key is used to set the frequency or sample rate.
		AMPL sets the waveform amplitude.
		Sets the DC offset.



The UTIL key is used to access the save and recall options, update and view the firmware version, access the calibration options, system setting, Dual channel functions and frequency meter.



ARB is used to set the arbitrary waveform parameters.

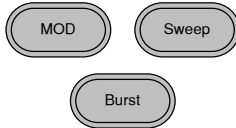

The MOD, Sweep and Burst keys are used to set the modulation, sweep and burst settings and parameters.

Preset Key



The preset key is used to recall a preset state.

Output Key



The Output key is used to turn on or off the waveform output.

Channel Select Keys

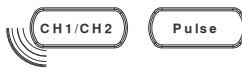

The channel select key is used to switch between the three output channels.

Output ports

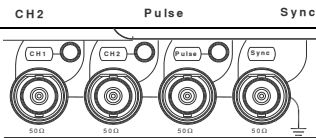

CH1: Channel 1 output port  
 CH2: Channel 2 output port  
 Pulse: Pulse output port  
 SYNC: SYNC output port

Power Button



Turns the power on or off.

USB Host



USB type-A host port.

Arrow Keys



Used to select digits when editing parameters.

Scroll Wheel

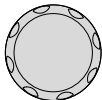

The scroll wheel is used to edit values and parameters.

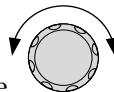

Decrease Increase

---

Keypad

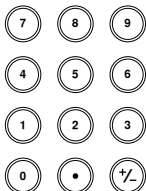

The digital keypad is used to enter values and parameters. The keypad is often used in conjunction with the arrow keys and variable knob.

---

MFG-2220HM Rear Panel

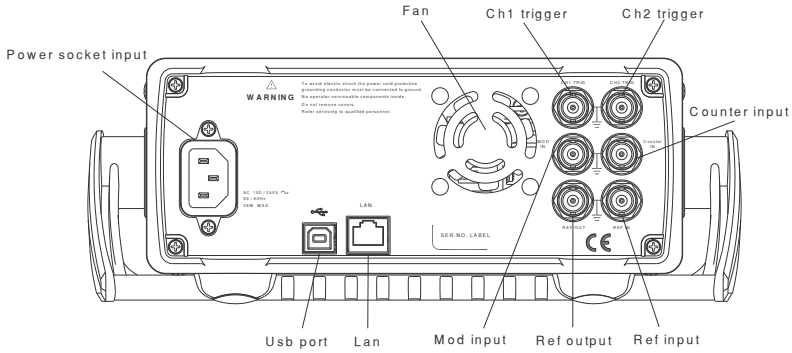

Fan

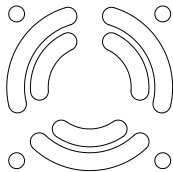

Fan.

Power Input Socket

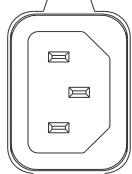

AC 100 / 240V ·  
50 / 60Hz ·  
35W MAX.

Power input:  
100~240V AC  
50~60Hz.

LAN Port

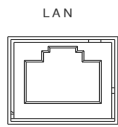

The LAN port is used for remote control over a network

USB Device Port



USB type-B device port is used to connect the function generator to a PC for remote control.

CH1/CH2  
Trigger

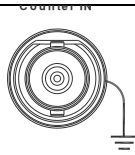

External trigger input. Used to receive external trigger signals..

Counter Input

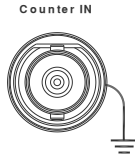

Frequency counter input.

MOD Input

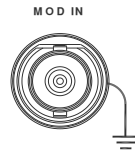

Modulation input terminal.

REF OUT  
REF IN

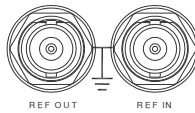

26.8436 MHz reference output.

26.8436 MHz reference input.

## Display

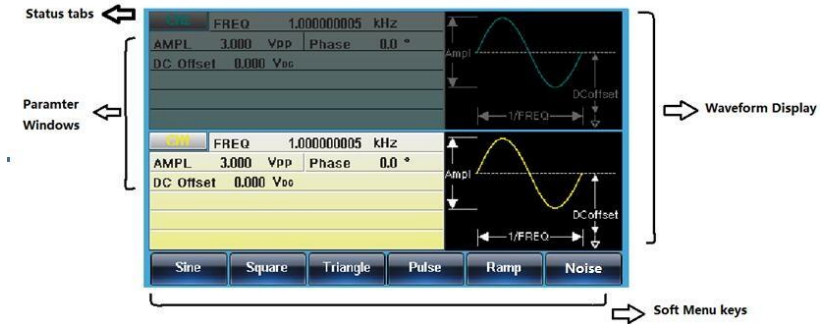

**Parameter Windows**      The Parameter display and edit window.

**Status Tabs**          Displays the current channel and setting status.

**Waveform Display**      Used to display the waveform

**Soft Menu Keys**      The function keys (F1~F6) under the LCD display correspond directly to the soft menu keys.



## Setting Up the function Generator

**Background** This section describes how to adjust the handle and power up the function generator.

**Adjusting the Handle**

Pull out the handle sideways and rotate it.

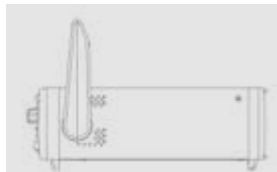

Place the MFG-2220HM horizontally,



Or tilt the stand.

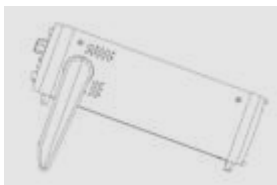

Place the handle vertically to hand carry.

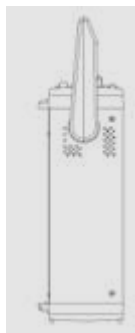

**Power Up**

1. Connect the power cord to the socket on the rear panel.

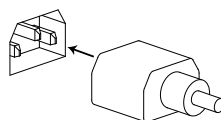

2. Turn on the power switch on the front panel.

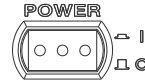

3. When the power switch is turned on the screen displays the loading screen.



The function generator is now ready to be used.

# QUICK REFERENCE

This chapter describes the operation shortcuts, built-in help and factory default settings. This chapter is to be used as a quick reference, for detailed explanations on parameters, settings and limitations, please see the operation chapters.

---

How to use the Digital Inputs .....	21
How to use the Help Menu .....	22
Selecting a Waveform .....	25
Square Wave .....	25
Ramp Wave.....	25
Sine Wave .....	26
Harmonic Wave.....	26
Modulation.....	28
AM Modulation .....	28
ASK Modulation .....	30
FM Modulation.....	32
FSK Modulation.....	33
PM Modulation.....	34
PSK Modulation.....	35
PWM Modulation .....	36
SUM Modulation.....	37
Sweep.....	39
Burst .....	41
ARB .....	43
ARB-Add Built-In Waveform.....	43
ARB- Add Point.....	43
ARB- Add Line.....	44
ARB- Output Section .....	44
Utility Menu .....	46

---

Save .....	46
Recall .....	46
Menu Tree .....	47
Waveform .....	48
Waveform_More .....	49
ARB-Display.....	50
ARB-Edit .....	51
ARB- Built In.....	52
ARB-Save .....	53
ARB-Load.....	54
ARB-Output.....	54
MOD_(CH1/CH2) .....	55
MOD_More(CH1/CH2).....	56
SWEEP .....	57
Burst- N Cycle.....	58
Burst – Gate .....	59
UTIL.....	60
CH1/CH2.....	63
Pulse.....	64
Default Settings.....	65

## How to use the Digital Inputs

### Background

The MFG-2220HM has three main types of digital inputs: the number pad, arrow keys and scroll wheel. The following instructions will show you how to use the digital inputs to edit parameters.

1. To select a menu item, press the corresponding function keys below (F1~F6). For example the function key F1 corresponds to the Soft key "Sine".



2. To edit a digital value, use the arrow keys to move the cursor to the digit that needs to be edited.

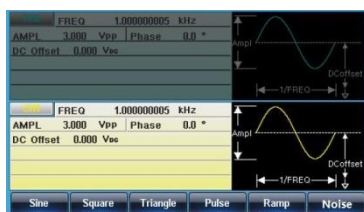

3. Use the scroll wheel to edit the parameter. Clockwise increases the value, counter clockwise decreases the value.

4. Alternatively, the number pad can be used to set the value of a highlighted parameter.

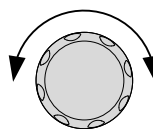

## How to use the Help Menu

**Background** Every key and function has a detailed description in the help menu.

1. Press UTIL



2. Press System (F4)



3. Press Help (F3)

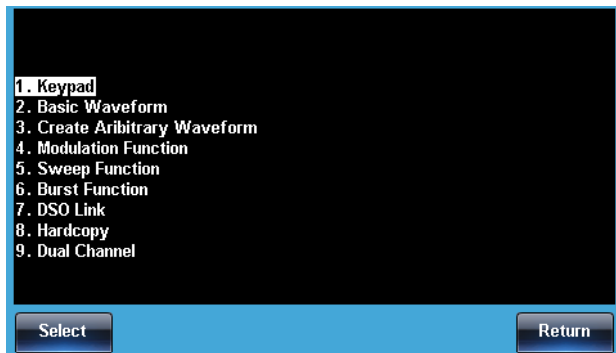

4. Use the scroll wheel to navigate to a help item. Press Select to choose the item.

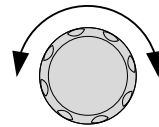

Keypad	Provides help on any front panel key that is pressed.
Create Arbitrary Waveform	Provides help on creating arbitrary waveforms.
Modulation Function	Explains how to create Modulated waveforms.

Sweep Function	Provides help on the Sweep function.
Burst Function	Provides help on the Burst function.
DSO Link	Provides help on DSO link.
Hardcopy	Explains how to use the Hardcopy function.

5. For example, select item 5 to see help on the sweep functions.



- Use the scroll wheel to navigate the help information.

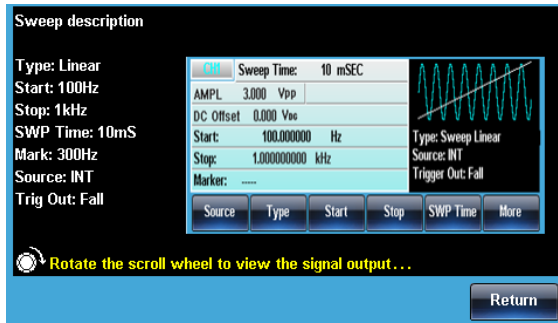

- Press Return to return to the previous menu.

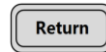



## Selecting a Waveform

### Square Wave

Example: Square wave, 3Vpp, 75% duty cycle, 1kHz.

Output:

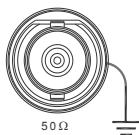

1. Press Waveform and select Square (F2).



2. Press Duty (F1), 7 + 5 + % (F5).



Input: N/A

3. Press Freq/Rate, 1 + kHz (F5).



4. Press AMPL followed by, 3 + VPP (F6).



5. Press the Output key.



### Ramp Wave

Example: Ramp Wave, 5Vpp, 10kHz, 50% Symmetry.

Output:

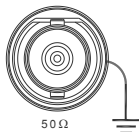

1. Press the Waveform key, and select Ramp (F5).





2. Press SYM (F1), 5 + 0 + % (F5).



Input: N/A

3. Press the Freq/Rate key then 1 + 0 + kHz (F5).



4. Press the AMPL key then 5 +VPP (F6). 
5. Press the Output key. 



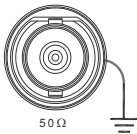

## Sine Wave

Example: Sine Wave, 10Vpp,100kHz

Output:



Input: N/A

1. Press the Waveform key and select Sine (F1). 
2. Press the Freq/Rate key, followed by 1 + 0 +0 + kHz (F5). 
3. Press the AMPL key, followed by 1 + 0 +VPP (F6). 
4. Press the output key. 

## Harmonic Wave

Example: 10kHz harmonic sine wave, odd & even (all) harmonics, up to the 3rd order (2nd(5Vpp), 3rd(2Vpp), 0° phase.

Output

1. Press the Waveform key and select More Harmonic (F3). 

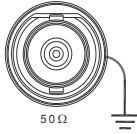

Input: N/A

2. Press Total (F1), followed by 3 + Enter (F1).



3. Press Type (F2), ALL (F3).



4. Press Order (F3).



5. Press Order (F1), followed by 2 + Enter (F5).



Press Amp(F2), followed by 5 + VPP (F5).



Press Phase(F3), followed by 0 + Degree (F5).



6. Press the Order (F1), followed by 3 + Enter (F5).



Press Amp(F2), followed by 2 + VPP (F5).



Press Phase(F3), followed by 0 + Degree (F5).



7. Press the output key.



# Modulation

## AM Modulation

Example: AM modulation. 100Hz modulating square wave. 1kHz Sine wave carrier. 80% modulation depth.

Output:

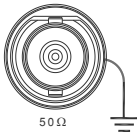

Input: N/A

Press the MOD key and select AM (F1).



1. Press Waveform and select Sine (F1).



2. Press the Freq/Rate key, followed by 1 + kHz (F5).



3. Press the MOD key, select AM (F1), Shape (F4), Square (F2).



4. Press the MOD key, select AM (F1), AM Freq (F3).



5. Press 1 + 0 + 0 + Hz (F2).



6. Press the MOD key, select AM (F1), Depth (F2).



7. Press 8 + 0 + % (F1).



8. Press MOD, AM (F1), Source (F1), INT (F1).



9. Press the Output key.









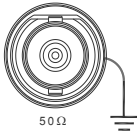

## ASK Modulation

Example: ASK modulation. 50% duty cycle. 1kHz sine carrier wave. 10Hz rate . Internal source.

Output:



Input: N/A

1. Press MOD and then select More(F6) and then press F2(ASK).
 
2. Press Waveform and select Sine(F1).
 
3. Press the Freq/Rate key, followed by 1 + kHz (F5).
 
4. Press the MOD key, select More(F6) first then ASK(F2), ASK Rate (F3).
 
5. Press 1+ 0 + Hz (F2)
 
6. Press the MOD key, select More(F6) first then ASK(F2), ASK Ampl(F2).
 
7. Press 5+0+0+mVpp(F1).
 
8. Press MOD, More(F6),ASK(F2), Source (F1), INT (F1).
 

9. Press the Output key.









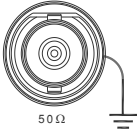

## FM Modulation

Example: FM modulation. 100Hz modulating square wave. 1kHz Sine wave carrier. 100 Hz frequency deviation. Internal Source.

Output:

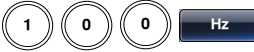

Input: N/A

1. Press the MOD key and select FM (F2).
 
2. Press Waveform and select Sine (F1).
 
3. Press the Freq/Rate key, followed by 1 + kHz (F5).
 
4. Press the MOD key, select FM (F2), Shape (F4), Square (F2).
 
5. Press the MOD key, select FM (F2), FM Freq (F3).
 
6. Press 1 + 0 + 0 + Hz (F2).
 
7. Press the MOD key, select FM (F2), Freq Dev (F2).
 
8. Press 1 + 0 + 0 + Hz (F3).
 
9. Press MOD, FM (F2), Source (F1), INT (F1).
 



10. Press the Output key.



## FSK Modulation

---

Example: FSK modulation. 100Hz Hop frequency. 1kHz Carrier wave. Sine wave. 10 Hz Rate. Internal Source.

Output:

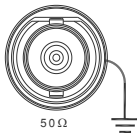

1. Press the MOD key and select FSK (F3).



2. Press Waveform and select Sine (F1).



Input: N/A

3. Press the Freq/Rate key, followed by 1 + kHz (F5).



4. Press the MOD key, select FSK (F3), FSK Rate (F3).



5. Press 1 + 0 + Hz (F2).



6. Press the MOD key, select FSK (F3), Hop Freq (F2).



7. Press 1 + 0 + 0 + Hz (F3).



8. Press MOD, FSK (F3), Source (F1), INT (F1).



9. Press the output key.



## PM Modulation

---

Example: PM modulation. 800Hz sinusoidal carrier wave. 15 kHz modulating sine wave. 180° phase deviation. Internal Source.

Output:

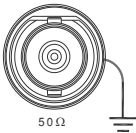

1. Press Waveform and select Sine (F1).



2. Press the MOD key and select PM (F4).



Input: N/A

3. Press the Freq/Rate key, followed by 8 + 0 + 0 + Hz (F4).

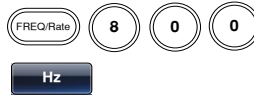

4. Press the MOD key, select PM (F4), Shape (F4), Sine (F1).



5. Press MOD, then PM (F4), PM Freq (F3).



6. Press 1 + 5 + kHz (F3).





7. Press MOD, PM (F4), Phase Dev (F2).



8. Press 5 + 0 + Degree (F1).



9. Press MOD, PM (F4), Source (F1), INT (F1).
- 

10. Press the Output key.
- 

## PSK Modulation

Example: PSK modulation. 50° phase deviation. 1kHz sine carrier wave. 10Hz PSK rate. Internal source.

Output

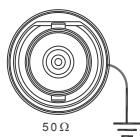



1. Press MOD and select More (F6) first then PSK (F3).
- 

2. Press Waveform and select Sine(F1).
- 



Input: N/A

3. Press the Freq/Rate key, followed by 1 + kHz (F5).
- 

4. Press the MOD key, select More (F6) first then PSK(F3), PSK Rate (F3).
- 

5. Press 1 + 0 + Hz (F2)
- 

6. Press the MOD key, select More (F6) first then PSK(F3), PSK Phase (F2).
- 





7. Press 5+ 0 + Degree(F1)
 
8. Press MOD, More (F6) first then PSK(F3), Source (F1), INT (F1)
 
9. Press the Output key
 



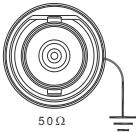

## PWM Modulation

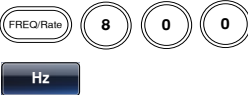
Example: PWM modulation. 800Hz carrier, 15kHz modulated sine wave. 50% duty cycle. Internal source.

Output:



1. Press Waveform and select Square (F2)
 
2. Press MOD and select More(F6) first then select PWM(F1)
 
3. Press the Freq/Rate key, followed by 8+0+0 Hz (F4).
 
4. Press the MOD key, select More (F6) first then PWM (F1), Shape (F4), Sine(F1).
 
5. Press MOD, select More (F6) first then PWM(F1), PWM Freq(F3)
 



6. Press 1 + 5+ kHz (F3). 
7. Press MOD, select More (F6) first then PWM(F1),Duty(F2) 
8. Press 5 + 0 + % (F1) 
9. Press MOD, More(F6), PWM(F1) Source(F1),INT(F1) 
10. Press the Output key. 

## SUM Modulation

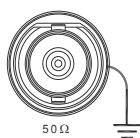

Example: SUM modulation. 100Hz modulating square wave, 1kHz sinusoidal carrier wave, 50% SUM amplitude, internal source.





Output:

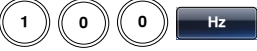

1. Press the MOD key, then SUM (F5). 
2. Press Waveform, and select Sine (F1). 

Input: N/A

3. Press Freq/Rate followed by 1 + kHz (F5). 
4. Press the MOD key, SUM (F5), Shape (F4), Square (F2). 

5. Press the MOD key and select SUM (F5), SUM Freq (F3).
 
6. Press 1 + 0 + 0 + Hz (F2).
 
7. Press the MOD key and select SUM (F5), SUM Ampl (F2).
 
8. Press 5 + 0 + % (F1).
 
9. Press MOD, SUM (F5), Source (F1), INT (F1).
 
10. Press the Output key.
 

## Sweep

Example: Frequency Sweep. Start Frequency 10mHz, Stop frequency 1MHz. Log sweep, 1 second sweep, Marker Frequency 550 Hz, Manual Trigger.

Output:

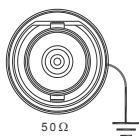

1. Press Sweep, Start (F3).



2. Press 1 + 0 + mHz (F2).



3. Press Sweep, Stop (F4).



Input: N/A

4. Press 1 + MHz (F5).



5. Press Sweep, Type (F2), Log (F2).



6. Press Sweep, SWP Time (F5).



7. Press 1 + SEC (F2).



8. Press Sweep, More (F6), Marker (F3), ON/OFF (F2), Freq (F1).



9. Press 5 + 5 + 0 + Hz (F3).



10. Press the Output key.



11. Press Sweep, Source (F1), Manual (F3), Trigger (F1).





## Burst

Example: Burst Mode, N-Cycle (Internally triggered), 1kHz burst frequency, Burst count = 5, 10 ms Burst period, 0° burst phase, Internal trigger, 10 us delay, rising edge trigger out

Output:

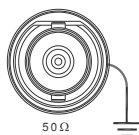

1. Press **FREQ/Rate** 1 kHz (F5).



2. Press **Burst, N Cycle** (F1), **Cycles** (F1).



Input: N/A

3. Press **5 + Cyc** (F5).



4. Press **Burst, N Cycle** (F1), **Period** (F4).



5. Press **1 + 0 + msec** (F2).



6. Press **Burst, N Cycle** (F1), **Phase** (F3).



7. Press **0 + Degree** (F5).



8. Press **Burst, N Cycle** (F1), **TRIG set** (F5), **INT** (F1).



9. Press **Burst, N Cycle** (F1), **TRIG set** (F5), **Delay** (F4).



10. Press **1 + 0 + uSEC** (F5).



11. Press Burst, N Cycle  
(F1), TRIG setup (F5),  
TRIG out (F5),  
ON/OFF (F3), Rise  
(F1).



12. Press the Output key.



## ARB

### ARB–Add Built-In Waveform

Example: ARB Mode, Exponential Rise. Start 0, Length 100, Scale 327.

Output:

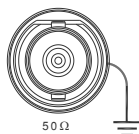

1. Press ARB, Built in (F3), Wave (F4), Math(F2), use the scroll wheel to select Exporise and then press Select(F5).



2. Press Start (F1), 0 + Enter (F2), Return.



3. Press Length (F2), 100, Enter (F2), Return.



4. Press Scale (F3), 327, Enter (F2), Return, Done (F5).



### ARB- Add Point

Example: ARB Mode, Add point, Address 40, data 300.

Output:

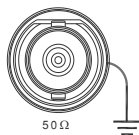

1. Press ARB, Edit (F2), Point (F1), Address (F1).



2. Press 4 + 0 + Enter (F5), Return.



3. Press Data (F2),  
3+0+0, Enter (F5).

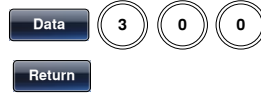

## ARB- Add Line

Example: ARB Mode, Add line, Address:Data (10:30, 50:100)

Output:

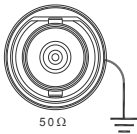

1. Press ARB, Edit (F2),  
Line (F2), Start ADD  
(F1).



2. Press 1 + 0 + Enter  
(F5), Return.



3. Press Start Data (F2),  
3 + 0, Enter (F5),  
Return.



4. Press Stop ADD (F3),  
5 + 0, Enter (F5),  
Return.



5. Press Stop Data (F4),  
1 + 0 + 0, Enter (F5),  
Return, Done (F5).



## ARB- Output Section

Example: ARB Mode, Output ARB Waveform, Start 0, Length 1000.

- Output:
1. Press ARB, Output  
(F6).



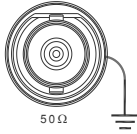

2. Press Start (F1), 0 + Enter (F5), Return.

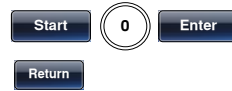

3. Press Length (F2), 1 + 0 + 0, Enter (F5), Return.





## Utility Menu

### Save

---



Example: Save to Memory file #5.

1. Press UTIL, Memory (F1), Store (F1).  

2. Choose a setting using the scroll wheel and press Done (F5).  

### Recall

---

Example: Recall Memory file #5.

1. Press UTIL, Memory (F1), Recall (F2).  

2. Choose a setting using the scroll wheel and press Done (F5).  

## Menu Tree

**Conventions** Use the menu trees as a handy reference for the function generator functions and properties. The MFG-2220HM menu system is arranged in a hierarchical tree. Each hierarchical level can be navigated with the operation or soft menu keys. Pressing the Return key will return you to the previous menu level.

For example: To set the interface to USB;

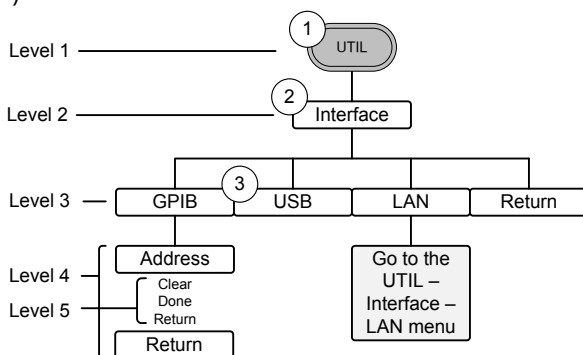
- (1) Press the UTIL key.
- (2) The Interface soft-key.
- (3) USB.



Waveform

---

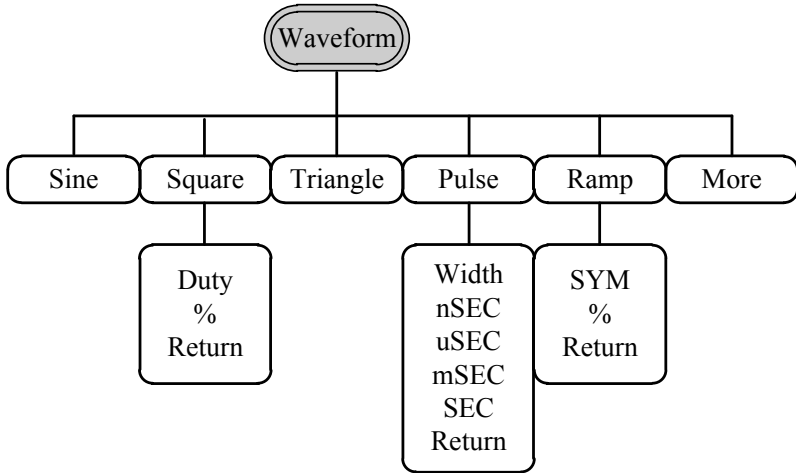



Waveform\_More

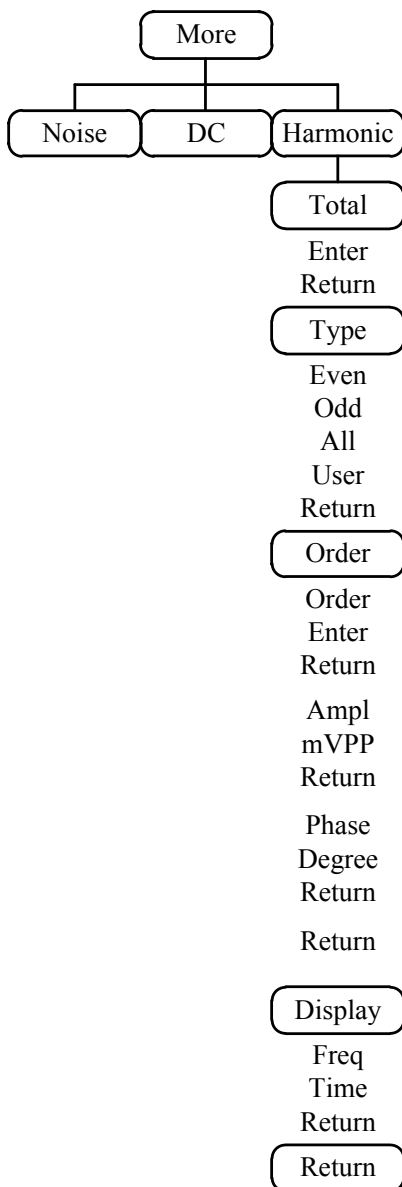

## ARB-Display

---

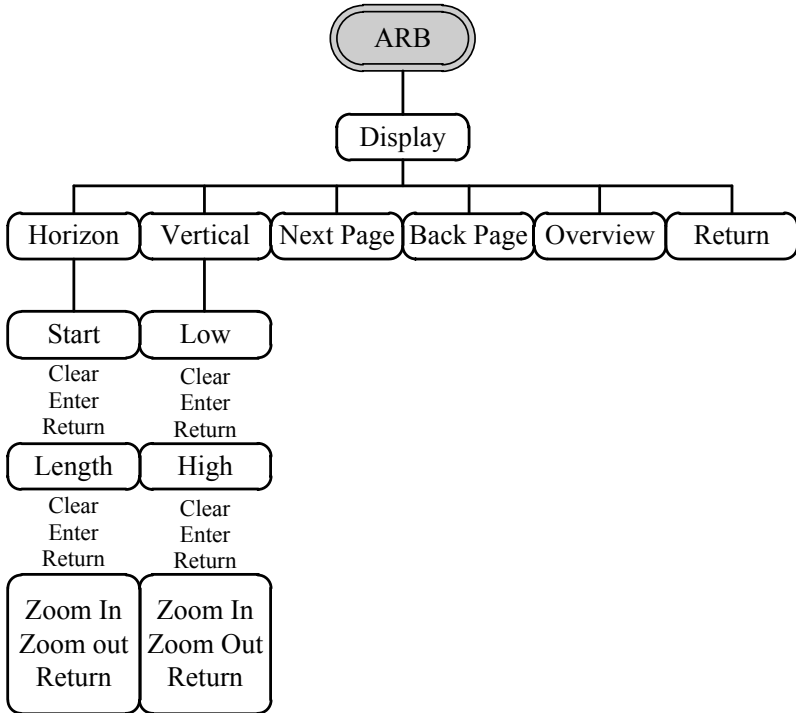

ARB-Edit

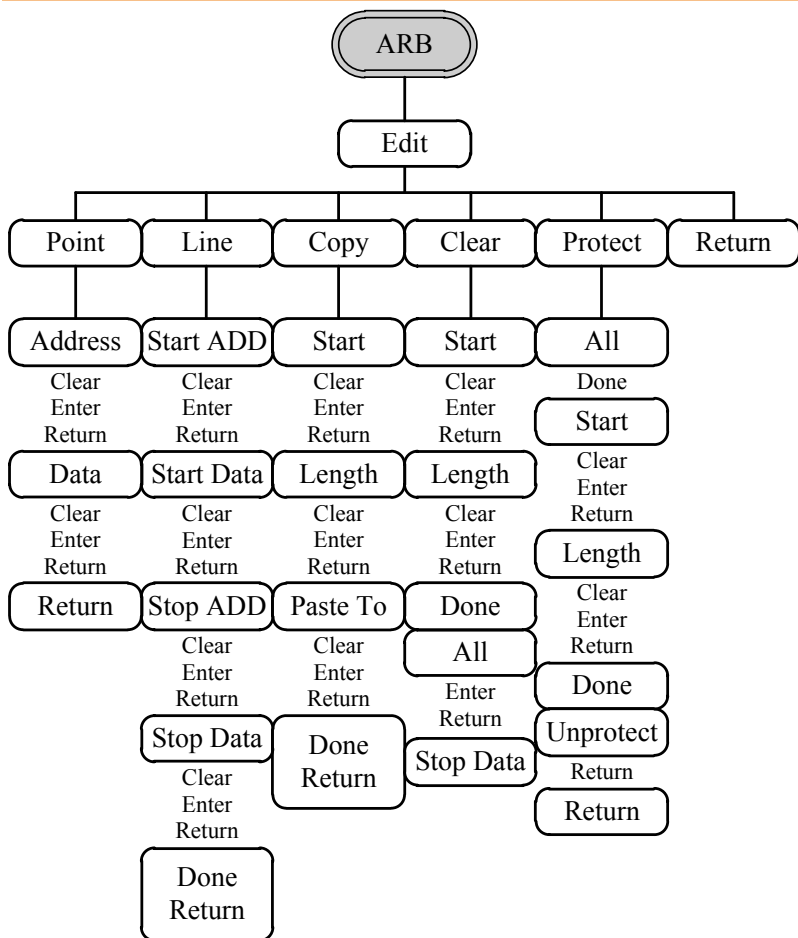

ARB- Built In

---

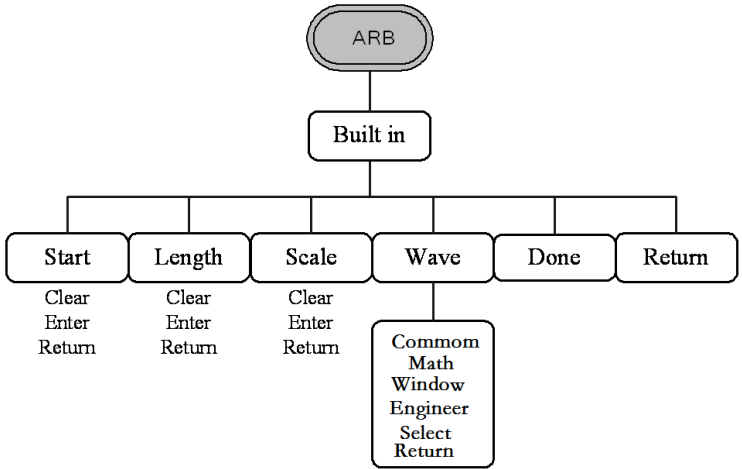

ARB-Save

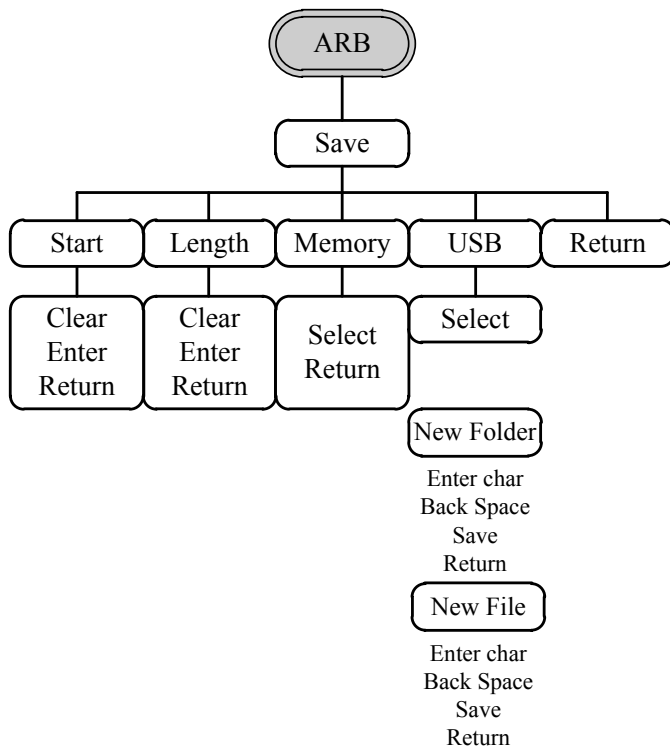

### ARB-Load

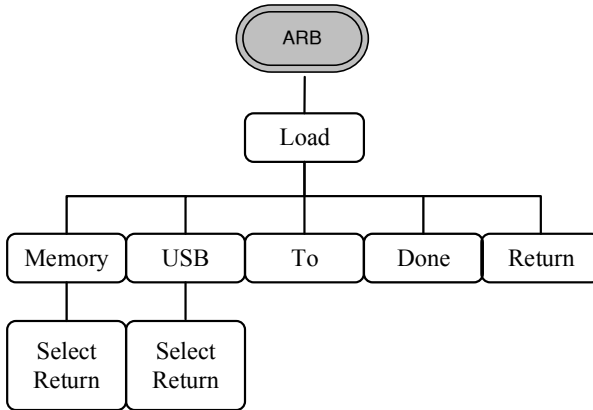

### ARB-Output

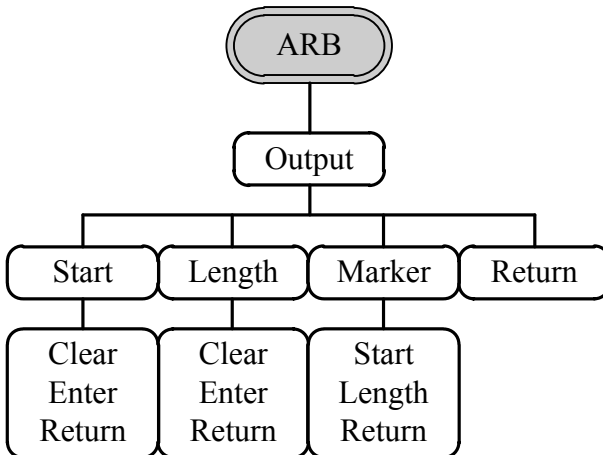

MOD\_(CH1/CH2)

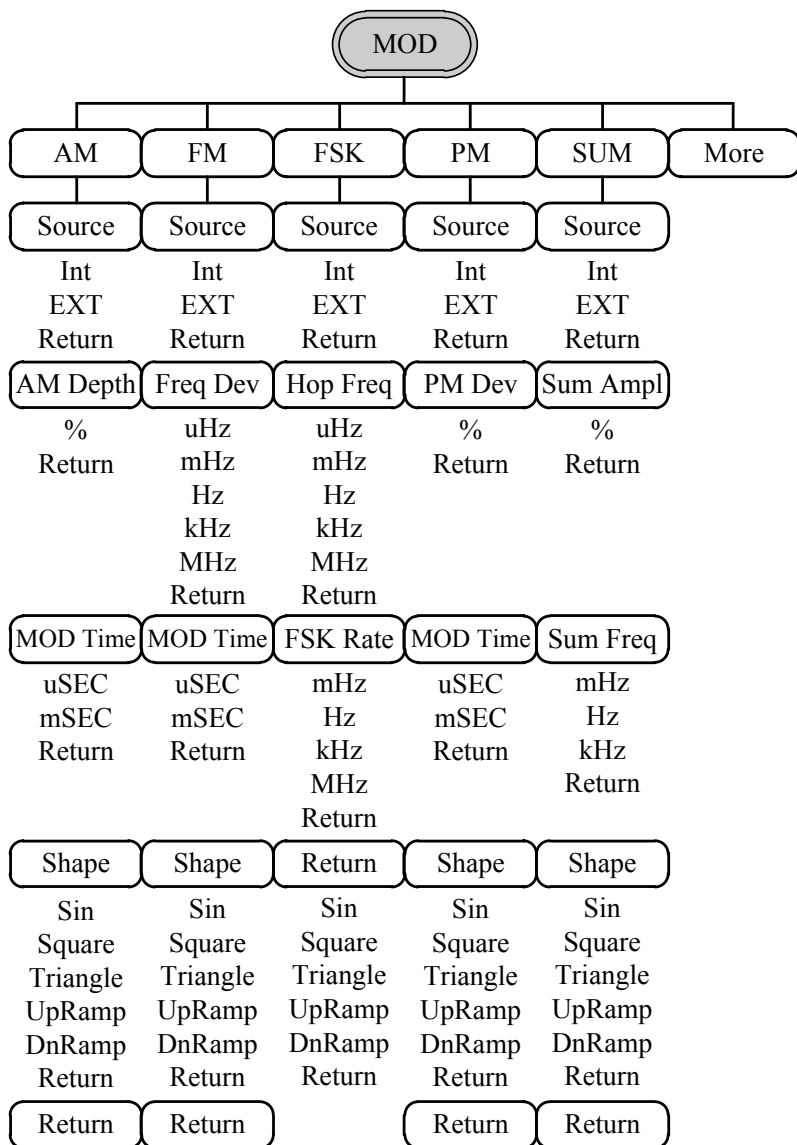

MOD\_More(CH1/CH2)

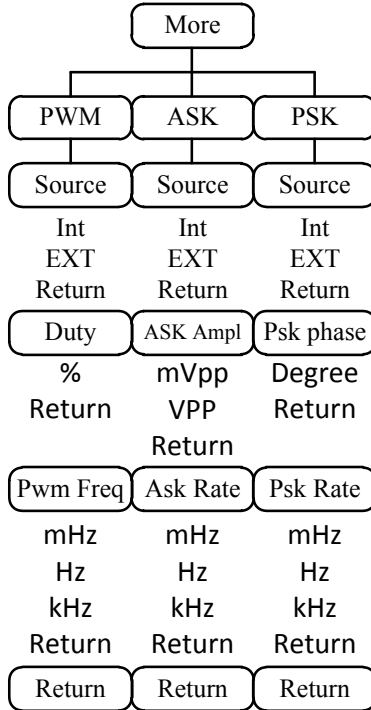



**SWEEP**

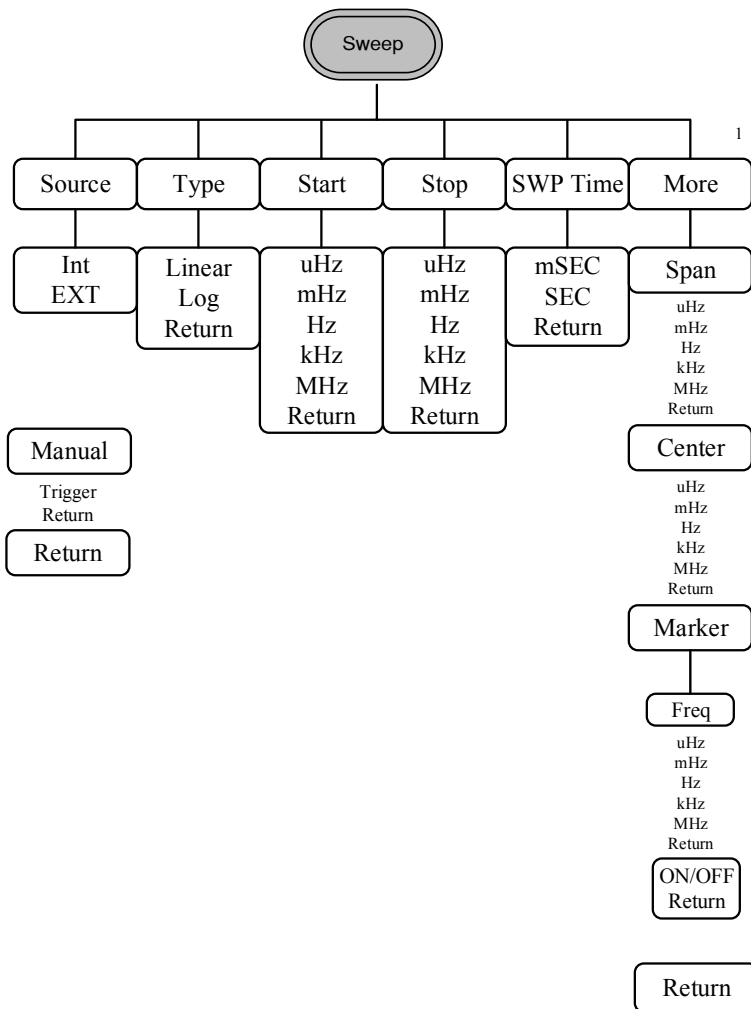

Burst- N Cycle

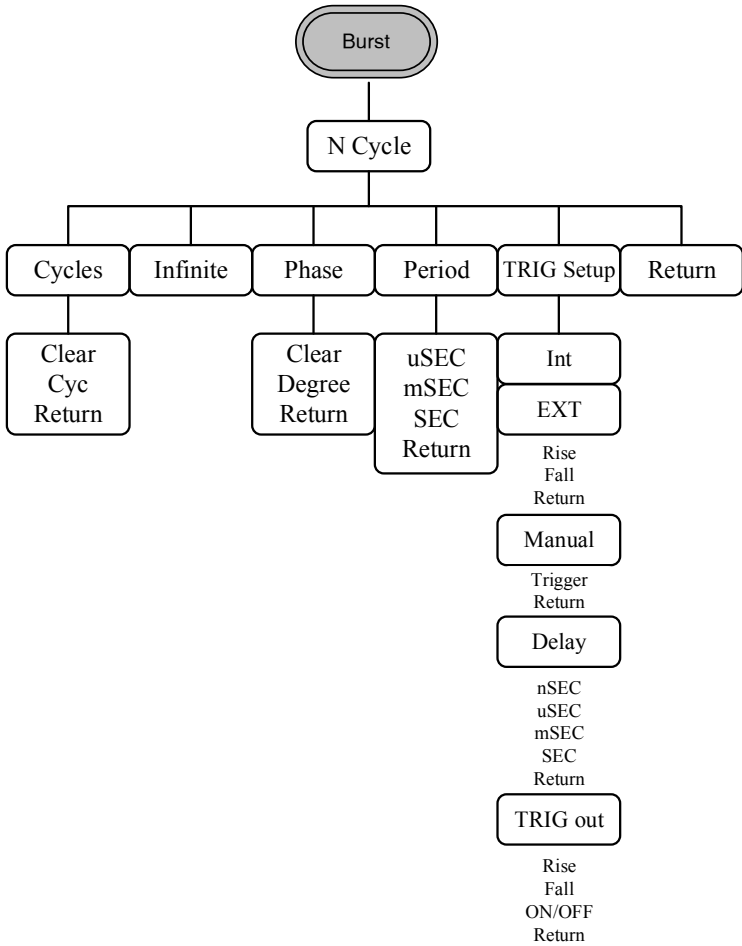

Burst – Gate

---

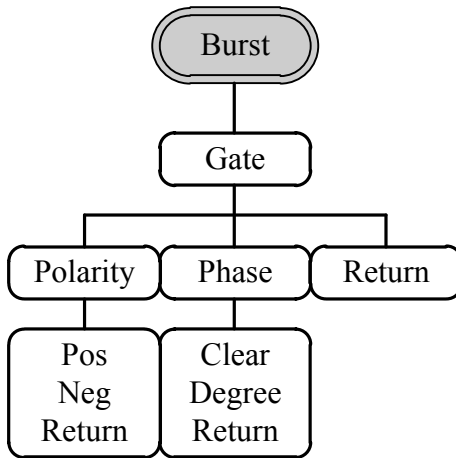

UTIL

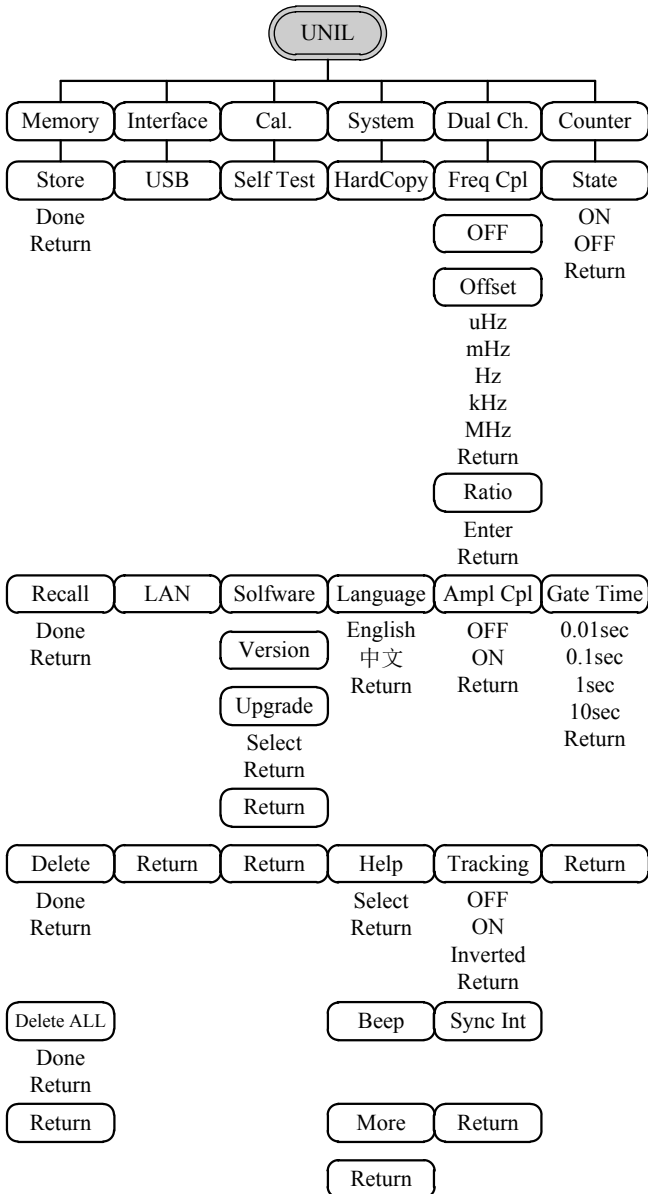

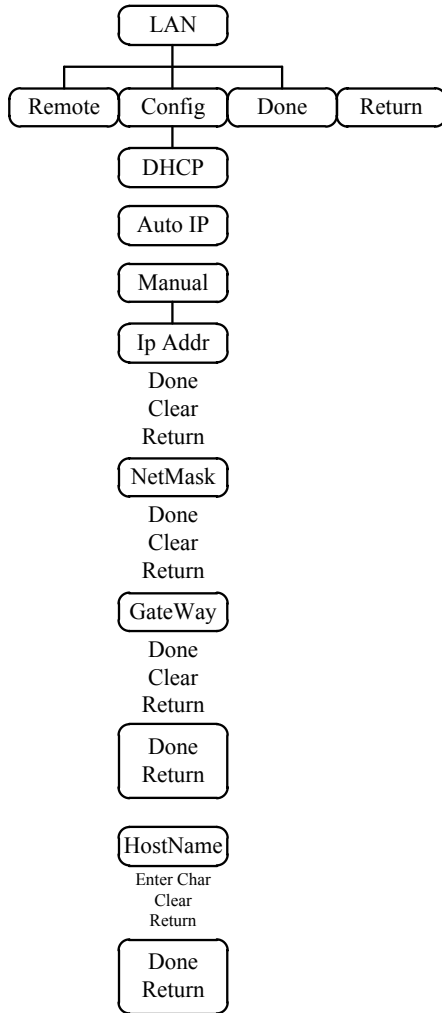

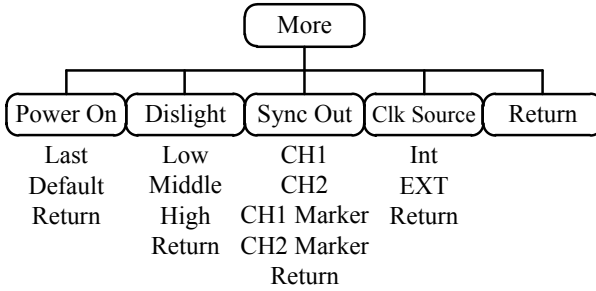

CH1/CH2

---

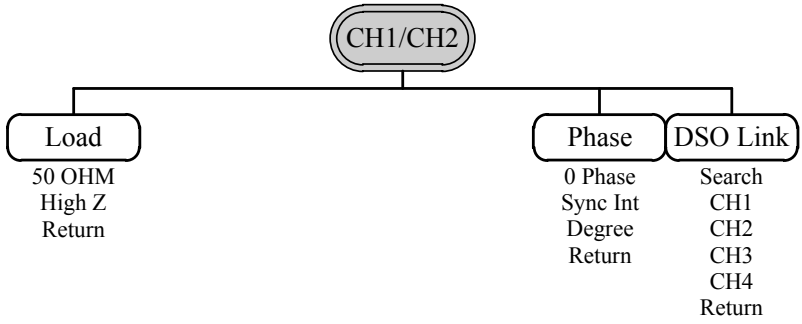

Pulse

---

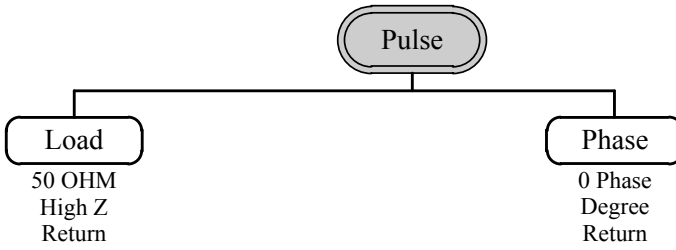



## Default Settings

The Preset key is used to restore the default panel settings.



Output Settings	Function	Sine Wave
	Frequency	1kHz
	Amplitude	3.000 Vpp
	Offset	0.00V dc
	Output units	Vpp
	Output terminal	50Ω
Modulation		
(AM/ASK/FM/FSK/PM/PSK/SUM)		
	Carrier wave	1kHz sine wave
	Modulation wave	100Hz sine wave
	AM depth	100%
	ASK amplitude	500mVpp
	ASK frequency	10Hz
	FM deviation	100Hz
	FSK hop frequency	100Hz
	FSK frequency	10Hz
	PM phase deviation	180°
	PSK phase	180°
	PSK frequency	10Hz
	SUM amplitude	50%
	Modem status	Off
PWM Modulation		
	Carrier wave	1kHz Square wave
	Modulation wave	20kHz sine wave

	PWM duty cycle	50%
	Modem status	Off
Sweep	Start/Stop frequency	100Hz/1kHz
	Sweep time	1ms
	Sweep type	Linear
	Sweep status	Off
Burst	Burst frequency	1kHz
	Ncycle	1
	Burst period	10ms
	Burst starting phase	0°
	Burst status	Off
System Settings	Power off signal	On
	Display mode	On
	Error queue	Cleared
	Memory settings	No change
	Output	Off
Trigger	Trigger source	Internal (immediate)
Calibration	Calibration Menu	Restricted

## MFG-2220HM Series Specifications

The specifications apply when the function generator is powered on for at least 30 minutes under +18°C~+28°C.

CH1/ CH2			
<b>Arbitrary Functions</b>	ARB function	Built-in	
	Sample Rate	500 MSa/s	
	Repetition Rate	125MHz	
	Waveform Length	16k points	
	Amplitude Resolution	14 bits	
	Non-Volatile Memory	10sets 16k points(1)	
	User-defined output section	From point 2~16384 (optional)	
<b>Frequency Characteristics</b>	Range	Sine	200MHz(max)
		Square	60MHz(max)
		Triangle, Ramp	5MHz
	Resolution	1μHz	
	Accuracy Stability	±20 ppm	
	Aging	±1 ppm, per 1 year	
	Tolerance	≤1μHz	
	<b>Output Characteristics(2)</b>	Amplitude Range	1mVpp to 10 Vpp
1 mVpp to 5 Vpp			≅ 70MHz
1 mVpp to 2 Vpp			≅ 120MHz
1 mVpp to 1 Vpp (into 50Ω)			≅ 200MHz
Accuracy		±2% of setting ±1 mVpp (at 1 kHz/into 50Ω without DC offset)	
Resolution		0.1mV or 4 digits	
Flatness		± 1% (0.1dB)	≅ 10MHz
	± 2% (0.2dB)	≅ 60 MHz	
	± 4% (0.4dB)	≅ 100 MHz	
	± 8% (0.8dB)	≅ 160 MHz	
	± 10% (1dB)	≅ 200 MHz	

		(sinewave relative to 100 kHz, 1Vpp ,into 50Ω)
	Units	Vpp, Vrms, dBm
<b>Offset</b>	Range	±5 Vpk ac +dc (into 50Ω) ±10Vpk ac +dc (Open circuit)
	Accuracy	1% of setting + 5mV+ 0.5% of amplitude
	<b>Waveform Output</b>	
	Impedance	50Ω typical (fixed) >10MΩ (output disabled)
	Protection	Short-circuit protected Overload relay automatically disables main output
<b>Sync Output</b>	Range	TTL-compatible into>1kΩ
	Impedance	50Ω standard
<b>Sine wave Characteristics(3)</b>		
	Harmonic Distortion	<-60 dBc <200kHz, <-55 dBc 200kHz~1 MHz, <-45 dBc 1MHz~10 MHz, <-35 dBc 10MHz~30 MHz, <-30 dBc 30MHz~200MHz, (at 1Vpp/into 50Ω without DC offset)
	Total harmonic distortion	< 0.1% (Ampl>1Vpp) 10Hz~100 kHz
<b>Square wave Characteristics</b>		
	Rise/Fall Time	<6ns
	Overshoot	<5%
	Asymmetry	1% of period +5 ns
	Variable duty Cycle	0.01% to 99.99%(limited by the current frequency setting)
	Jitter	20ppm+500ps (4)
<b>Ramp Characteristics</b>		
	Linearity	< 0.1% of peak output
	Variable Symmetry	0% to 100%
<b>Pulse Characteristics</b>		

	Frequency	1uHz~25MHz
	Pulse Width	≧ 10nS(limited by the current frequency setting)
	Variable duty Cycle	0.01%~99.99%(limited by the current frequency setting)
	Overshoot	<5%
	Jitter	20ppm+500ps(4)
<b>AM Modulation</b>		
	Carrier Waveforms	Sine, Square, Triangle, Ramp, Pulse,Arb
	Modulating Waveforms	Sine, Square, Triangle,Upramp, Dnramp
	Modulating Frequency	2mHz to 50kHz (Int) DC to 50kHz (Ext)
	Depth	0% to 120.0%
	Source	Internal / External
<b>FM Modulation</b>		
	Carrier Waveforms	Sine, Square, Triangle, Ramp
	Modulating Waveforms	Sine, Square, Triangle,Upramp, Dnramp
	Modulating Frequency	2mHz to 50kHz (Int) DC to 50kHz (Ext)
	Peak Deviation	DC to 0.5*max frequency
	Source	Internal / External
<b>PM Modulation</b>		
	Carrier Waveforms	Sine, Square, Triangle, Ramp
	Modulating Waveforms	Sine, Square, Triangle, Upramp, Dnramp
	Modulation Frequency	2mHz to 50kHz (Int) DC to 50kHz (Ext)
	Phase deviation	0° ~360.0°
	Source	Internal / External
<b>SUM Modulation</b>		
	Carrier Waveforms	Sine, Square, Triangle, Pulse,Ramp,Noise
	Modulating Waveforms	Sine, Square, Triangle, Upramp, Dnramp
	Modulation Frequency	2mHz to 50kHz (Int) DC to 50kHz (Ext)

	SUM depth	0%~100.0%
	Source	Internal / External
<b>PWM Modulation</b>	Carrier Waveforms	Pulse
	Modulating Waveforms	Sine, Square, Triangle, Upramp, Dnramp
	Modulation Frequency	2mHz to 50kHz (Int) DC to 50kHz (Ext)
	Width Depth	0%~100.0%
	Source	Internal / External
	<b>ASK</b>	Carrier Waveforms
	Modulating Waveforms	50% duty cycle square
	Internal Frequency	2mHz to 1 MHz
	Ampl Range	1mVpp to 10Vpp
	Source	Internal / External
<b>FSK</b>	Carrier Waveforms	Sine, Square, Triangle, Ramp,Pulse
	Modulating Waveforms	50% duty cycle square
	Internal Frequency	2mHz to 1 MHz
	Frequency Range	1μHz to max frequency
	Source	Internal / External
<b>PSK</b>	Carrier Waveforms	Sine, Square, Triangle, Ramp,Pulse
	Modulating Waveforms	50% duty cycle square
	Internal Frequency	2mHz to 1 MHz
	Phase Range	0° ~360.0°
	Source	Internal / External
<b>Sweep</b>	Waveforms	Sine, Square, Triangle, Ramp
	Type	Linear or Logarithmic
	Sweep direction	Sweep up or sweep down
	Start/Stop Freq	1uHz to max frequency
	Sweep Time	1ms to 500s
	Source	Internal / External

	Trigger	Single, External, Internal.
	Marker	Marker signal on falling edge(programmable)
	Source	Internal / External
<b>Burst</b>		
	Waveforms	Sine, Square, Triangle, Ramp
	Frequency	1uHz~MaxFrequency
	Pulse count	1~1000000 Cycles or infinite
	Start/ Stop Phase	-360.0° ~+360.0°
	Internal Frequency	1 us~500 s
	Gate source	External Trigger
	Trigger Source	Single, External, Internal.
<b>Trigger Delay</b>	NCycle, Infinite	0s~100 s
<b>External Trigger Input</b>		
	Type	For FSK, Burst, Sweep
	Input Level	TTL Compatibility
	Slope	Rising or Falling(Selectable)
	Pulse Width	>100ns
	Input Rate	DC to 1MHz
<b>External Modulation Input</b>		
	Type	For AM,FM, PM,SUM,PWM
	Voltage Range	±5V full scale
	Input Impedance	10kΩ
	Frequency	DC to 50kHz
<b>Trigger Output</b>		
	Type	For Burst,Sweep
	Level	TTL Compatible into 50Ω
	Pulse Width	>100ns
	Maximum Rate	1MHz
	Fan-out	≥4 TTL Load
	Impedance	50Ω Typical
<b>Reference Input</b>		
	Input Voltage	0.5Vp-p to 5Vp-p
	Output Impedance	1kΩ, unbalanced, AC coupled
	Input Frequency	26.8436MHz ± 10Hz

<b>Reference Output</b>	Waveform	Sine or square (50±5% duty)
	Output Voltage	3.3 Vp-p square wave
	Output Impedance	50Ω, AC coupled
	Output Frequency	26.8436MHz
<b>Frequency Counter</b>	Range	5Hz to 150MHz
	Accuracy	Time Base accuracy±1count
	Time Base	±20ppm (23 °C ±5 °C)
	Resolution	The maximum resolution is: 100nHz for 1Hz, 0.1Hz for 100MHz.
	Input Impedance	1kΩ/1pf
	Sensitivity	35mVrms ~ 30Vrms (5Hz to 150MHz)
	<b>Pulse Generator</b>	Amplitude
Offset		±1 Vpk ac +dc (into 50Ω) ±2Vpk ac +dc (Open circuit)
Frequency		1uHz~25MHz
Pulse Width		20nS~999.9ks (limited by the current frequency setting)
Variable duty Cycle		0.01%~99.99% (limited by the current frequency setting)
Leading and Trailing Edge Time(5)		10nS~20S (1ns resolution) (limited by the current frequency and pulse width settings)
Overshoot		<5%
Jitter		100ppm+500ps(4)
<b>Dual Channel Function (CH1/CH2)</b>		Phase
		Synchronize phase



Track	CH2=CH1
Coupling	Frequency(Ratio or Difference)
Dsolk	Amplitude & DC Offset √
<b>Save/Recall</b>	10 Groups of Setting Memories
<b>Interface</b>	LAN, USB
<b>Display</b>	4.3" TFT LCD 480 × 3 (RGB) × 272
<b>General Specifications</b>	
Power Source	AC100~240V, 50~60Hz
Power Consumption	35W (Max)
Operating Environment	Temperature to satisfy the specification : 18 ~ 28 °C Operating temperature : 0 ~ 40 °C Relative Humidity: ≤ 80%, 0 ~ 40 °C ≤70%, 35 ~ 40 °C Installation category : CAT II
Operating Altitude	2000 Meters
Storage Temperature	-10~70 °C, Humidity: ≤70%
Dimensions (WxHxD)	266(W) x 107(H) x293(D)mm
Weight	Approx. 2.8kg
Safety designed to	EN61010-1
Accessories	GTL-110× 2 Quick Start Guide ×1 CD (user manual + software) ×1 Power cord×1

- (1). A total of ten waveforms can be stored. (Every waveform can be composed of a maximum of 16k points.)
- (2). Add 1/10th of output amplitude and offset specification per °C for operation outside of 0°C to 28°C range (1-year specification).
- (3). DC offset set to zero,
- (4). Only Pluse channel support

## EC Declaration of Conformity

We

**GOOD WILL INSTRUMENT CO., LTD.**

No.7-1, Jhongsing Rd., Tucheng Dist., New Taipei City 236, Taiwan

**GOOD WILL INSTRUMENT (SUZHOU) CO., LTD.**

No. 69, Lushan Road, Suzhou New District Jiangsu, China

declares that the below mentioned product

### MFG-2220HM

Are here with confirmed to comply with the requirements set out in the Council Directive on the Approximation of the Law of Member States relating to Electromagnetic Compatibility (2004/108/EC&2014/30/EU) and Low Voltage Equipment Directive EMC: 2014/30/EU, LVD: 2014/35/EU, WEEE: 2012/19/EU and RoHS: 2011/65/EU. For the evaluation regarding the Electromagnetic Compatibility and Low Voltage Equipment Directive, the following standards were applied:

#### © EMC

EN 61326-1: EN 61326-2-2:	Electrical equipment for measurement, control and laboratory use — EMC requirements (2013)	
Conducted and Radiated Emissions EN 55011: 2016(Class A)	Electrostatic Discharge EN 61000-4-2: 2009	
Current Harmonic EN 61000-3-2: 2014	Radiated Immunity EN 61000-4-3: 2006+A1 : 2008+A2:2010	
Voltage Fluctuation EN 61000-3-3: 2013	Electrical Fast Transients IEC 61000-4-4: 2012	
-----	Surge Immunity EN 61000-4-5: 2014+A1:2017	
-----	Conducted Susceptibility EN 61000-4-6: 2014	
-----	Power Frequency Magnetic Field EN 61000-4-8: 2010	
-----	Voltage Dips/ Interrupts IEC 61000-4-11: 2004+A1:2017	

#### © Safety

Low Voltage Equipment Directive 2014/35/EU
Safety Requirements EN 61010-1: 2010(Third Edition)

