

Pro'sKit®

MT-1707

3-5/6 True-RMS Digital Multimeter



User's Manual
1st Edition, 2016

©2016 Copyright by Prokit's Industries Co., Ltd.

1. General Information

This digital multimeter is designed and manufactured in compliance with IEC-61010 safety requirements on electronic measuring instruments and hand-held digital multi-meters. It is compliant with IEC-61010 requirements pertaining to 600V CAT IV, 1000V CAT. III and requirements on pollution degree 2. Please read carefully this operation manual and pay attention to safety guidelines before operating this meter.

1.1 Safety information

1.1.1 Safety instructions

- * Before operating this meter, the operator must observe all standard safety procedures in the two respects below:
 - A. Safety procedures against electric shock
 - B. Safety procedures against unintended use
- * To ensure your personal safety, please use the test lead that accompanies the meter. Before operating this meter, ensure that the test lead is flawless.







1.1.2 Safety considerations

- * When the meter is used in the vicinity of the equipment that produces strong electromagnetic interferences, the reading on the meter will grow unstable and even produce serious errors.
- * Don't operate the meter or pen-shaped meter whose appearance is damaged.
- * The safety function of the meter will become null if the meter is not properly operated.
- * The meter must be operated with great care when working in the vicinity of an exposed conductor or bus line.
- * The meter is prohibited from being used in the vicinity of any explosive gas, vapor or dust.
- * The measurement must be made with correct input terminals and functions and within the allowable measuring range.
- * To prevent the meter from being damaged, the value to be input shall not exceed the extremes allowed by each measuring range.
- * When the meter has already been connected to the line being measured, the operator is prohibited from touching the input terminal that is not in service.
- * When the voltage measured exceeds 60Vdc or 30Vac (valid value), the operator shall be careful enough to avoid electric shock.
- * When making measurement with a test lead, place your fingers behind its protective ring.
- * When switching to another measuring range, be sure that test lead has already been taken off the measured circuit.

- * For all DC functions, to prevent potential electric shock as a result of incorrect reading, please first use AC functions to check the absence of any AV voltage. Then, select DC voltage measuring range equivalent to or greater than that for AC voltage.
- * Before the tests on electric resistance, diode, capacitor or continuity, the operator must cut off the power supply to the circuit to be measured, and discharge all high-voltage capacitors within the circuit to be measured.
- * The electric resistance measurement or continuity test cannot be carried out in any live electrical circuit.
- * Before the current measurement, the operator must first examine the protective tube of the meter. Before connecting the meter to the circuit to be measured, the operator must first power off the aforesaid circuit.
- * Before repairing TV sets or measuring power switching circuit, the operator must be careful enough to prevent high amplitude voltage impulse from damaging the meter.
- * This meter uses 4 x 1.5V AA batteries that must be correctly installed into the battery compartment.
- * When  appears, the batteries must be replaced immediately. The low level of a battery will result in incorrect reading on the meter, which is likely to bring electric shock or personal injury to the operator.
- * In measurement, category III voltage and category IV voltage shall not exceed 1000V and 600V respectively.
- * The meter shall not be in service if its case (or part of its case) is dismantled.

1.1.3 Safety symbol:

The safety symbols that appear on the meter's body and in this Operation Manual:

	Warning, an important safety symbol. The operator must consult this Operation Manual before using the meter. Unintended use may lead to the damage to the device or its components.
	AC (alternating current)
	DC (direct current)
	AC/DC
	Ground
	Double insulation protection
	Fuse

CE	Compliant with European Union Directive
	High voltage warning
CAT. III 1000 V	over-voltage protection
CAT. IV 600 V	over-voltage protection

1.1.4 Maintenance practices for safety

- * The operator must first pull out the test lead when the meter's case is opened or the battery cover is dismantled.
- * The designated replacement parts must be used at the moment of maintenance.
- * The operator must cut off all relevant power supplies before opening the meter. At the same time, the operator must avoid damage to the meter's elements by ensure that he himself doesn't carry any static.
- * The meter can only be calibrated, repaired and maintained by professionals.
- * When the meter's case is opened, the operator must understand the fact that the presence of some capacitance may promise the dangerous voltages even if the power supply to the meter is cut off.
- * The operator should stop using and maintain the meter immediately if any abnormality has been observed on the meter. The operator must see to it that the meter cannot be in service unless it is proved conforming.
- * When the meter is left idle for a long period, the operator shall remove the battery and place it in a place free from high temperature and humidity.

1.2 Input protection measures

- * The meter can sustain the maximum input voltage of 1000V (DC) or 750V (AC) at the moment of voltage measurement.
- * The meter can sustain the maximum AC voltage of 600V or equivalent voltage (valid value) when the tests on frequency, electric resistance, continuity and diode are carried out.
- * The protective tube (FF600mA/1000V) is used for protection purpose when μ A and mA current measurements are carried out.

2. A Schematic Diagram for the Meter

This meter is a hand-held digital multi-meter with the function of displaying True RMS. It is a large-screen LCD unit with backlight and illumination light functions so that the user can easily recognize reading. It is equipped with the function of overload protection and the indicator of battery under voltage. Either for professionals, factories, schools, enthusiasts or households, it is an ideal multi-functional meter.

2.1 A Schematic Diagram for the Meter

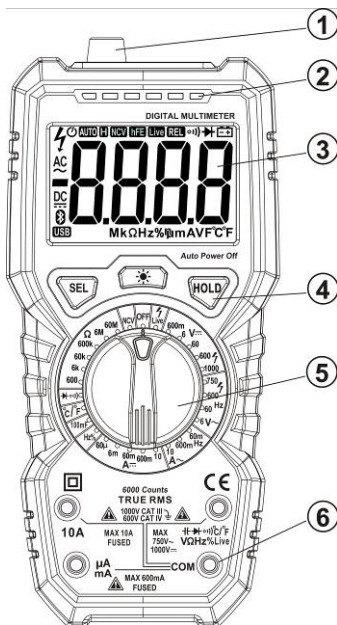

Physical appearance

- ①. Non-contact voltage detection area ②. Non-contact voltage indicator
③. LCD screen ④. key ⑤. Rotary switch ⑥. input socket

2.2 Description of the symbols on the display unit

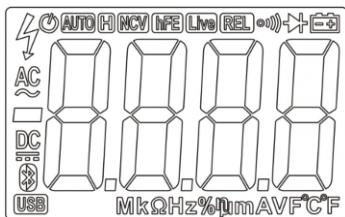

Fig. 1 (Display panel)

Table.1 Symbols

Symbol	Description
	Battery Under Voltage indicator/ Low Battery ⚠ To avoid electric shock or personal injury as a result of incorrect reading, promptly replace the battery when the battery under voltage indicator appears.
	Auto power off indicator
	High voltage warning
	Negative input polarity indicator
	Input voltage AC
	Input voltage DC
	Switching on/off test mode
	Diode test mode
	Automatic range measurement mode
	Data hold mode
°C , °F	Unit of temperature(°C: Celsius; °F: Fahrenheit)
%	Duty ratio
NCV	Non-contact AC voltage detection mode
Live	Live line judgment mode

Table.1 Symbols (Continued)

V, mV	V: mV :	V: the unit of volt Millivolt , 1×10^{-3} or 0.001 volt.
A, mA, μA	A: mA: μ A:	Ampere, the unit of current. Milliampere, 1×10^{-3} or 0.001 ampere. Microampere, 1×10^{-6} or 0.000001 ampere.
Ω, kΩ, MΩ	Ω : k Ω : M Ω :	Ohm, the unit of electric resistance. Kilohm, 1000 Ohm Megaohm, 1,000,000 ohm.
MkHz	Hz: KHz: MHz:	Hz, the unit of frequency KHz, 1×10^3 Hz. MHz, 1×10^6 Hz or 1000 KHz.
mF,μF, nF	F: mF: μ F: nF:	Farad, the unit of capacitance. Millifarad, 1×10^{-3} or 0.001 farad. Microfarad, 1×10^{-6} or 0.000001 farad. nF, 1×10^{-9} or 0.000000001 farad.

2.3 Description of functional keys

Key	Description of functions
SEL	SEL keys, e.g. Temperature measurement position: °C mode or °F mode. Frequency measurement position: HZ measurement mode or duty ratio (%) measurement mode AC voltage position and AC current position: press the key to select voltage/frequency mode or current/frequency mode in the AC voltage measurement mode or AC current measurement mode.
HOLD	Press the key to hold the measured value for the current moment Press the key again to cancel this function.
	Press the key, the backlight and the illumination indicator will be on; however, with another press on the same key, you will turn off backlight and illumination indicator. If you don't press the key at all, the function will automatically be disabled in 15 minutes.

2.4 Description of input socket

input socket	Description
COM	All public input terminals to be measured are connected to test leads in black or the public output plugs of exclusive multi-function test sockets.
 o)) °C/°F VΩ Hz% lives	Positive input terminals (connected to a test lead in red) for capacitor measurement, diode measurement, beep on/off test, temperature measurement, voltage measurement, electric resistance, frequency, duty ratio and live/earth line judgment.
μA mA	μA and mA positive input terminal (connected to a test lead in red).
10A	10A positive input terminal (connected to a test lead in red).

2.5 Accessories

- Operation Manual X 1
- Test lead X 1 pair
- K-Type thermocouple X 1

3. Operational guidelines

3.1 Normal operation

3.1.1 Hold mode

In the hold mode, the reading can be maintained on the display unit.

Changing the measurement function position or pressing the key.

Hold again to exit the hold mode



Hold mode: entry and exit

1. Press the key “H” and the reading will be held and the symbol “” will appear on the LCD screen.
2. Press the key “H” again to restore the meter to its status for normal measurement.

3.1.2 Backlight & lighting

The meter is equipped with the functions of backlight and lighting so that the operator can access measurement results even if he is in a darker place.

The backlight function can be enabled or disabled by the steps below:

1. Press the key  to enable backlight and illumination light.
2. Press the key  again to manually disable backlight and illumination light; wait for 15 seconds until the backlight and illumination light are automatically disabled.

3.1.3 Auto power off

If no operations are made in 15 seconds following the initialization, the meter will sound to remind the operator to automatically cut off power supply and enter the state of dormancy. The meter can be rebooted when the operator presses any key in the auto power off mode.

3.2 Measurement guidelines

3.2.1 Measurement of AC voltage and DC voltage



To avoid any electric shock and/or damage to the meter, do not attempt a voltage measurement if the voltage (valid value) is 1,000V for DC current or 750V for AC current. To avoid any electric shock and/or damage to the meter, don't attempt to impose between any public terminal and ground any voltage whose valid value is over 1,000V for DC current or 750V for AC current.

The meter provides DC voltage measuring ranges as follows: 600.0mV, 6.000V, 60.00V, 600.0V and 1000V, and AC voltage measuring ranges: 6.000V, 60.00V, 600.0V and 750V.

Measurement of AC voltage or DC voltage

- Turn the rotary switch to the position $\sim V$ or $\text{---}V$.
- Connect the test lead in black and test lead in red to COM input socket and V input socket respectively.
- Use another two ends of the test lead to measure the voltage of the circuit to be measured. (In parallel connection with the circuit to be measured)
- Read the measured voltage value on LCD screen. When DC voltage measurement is attempted, the display unit will show the voltage polarity of the circuit connected to the pen-shaped meter in red.

Notes:

- Within the measuring range of DC voltage of 600mV and AC voltage of 6V, even if there is no input or no connection to the test lead, the meter will display some information. In this situation, press short circuit “V— Ω ” and “COM” terminal to reset the meter to zero.

- Within the AC voltage function, press the key "SEL" to measure the frequency of the AC voltage source. Please refer to the relevant part for frequency measurement.
- The value of the AC voltage measured with this meter is True RMS (root mean square). These measurements are accurate for sine wave and other waves (without DC offset), square wave, triangular wave and step wave.

3.2.2 Electric resistance measurement



To avoid the meter or the measured equipment from damage, do not attempt a resistance measurement unless the operator has already cut off all power sources for the circuit to be measured and fully discharged all high-voltage capacitors.

Ohm is the unit of electric resistance (Ω).

The measuring ranges of electric resistance of this meter are 600.0 Ω , 6.000k Ω , 60.00k Ω , 600.0k Ω , 6.000M Ω and 60.00M Ω ,

Measurement of electric resistance

1. Turn the rotary switch to the appropriate position.
2. Connect the test lead in black and test lead in red to COM input socket and V/ Ω input socket respectively.
3. Use another two ends of the test lead to measure the electric resistance of the circuit to be measured.
4. Read the measured electric resistance value on LCD screen.

Notes:

- The measured value of the electric resistance of the circuit differs a bit from the rated value of the electric resistance.
- To ensure measurement accuracy, in attempting a low resistance measurement, first put two pen-shaped meters in short circuit and capture the resistance reading of these short circuits. Then subtract the aforesaid reading from the measured resistance.
- At 60M Ω position, you have to wait a few seconds before the reading grow stable. This is quite normal for a high resistance measurement.
- When the meter is in open circuit, the display unit will show "OL" that indicates the measured value is over the measuring range.

3.2.3 Diode test

 **To avoid the meter or the measured equipment from damage, do not attempt a diode test unless the operator has already cut off all power sources for the circuit to be measured and fully discharged all high-voltage capacitors.**

Diode test outside the circuit:

1. Turn the rotary switch to the position  .
2. Connect the test leads in black and in red to COM input socket and V/Ω input socket respectively.
3. Connect the test leads in black and in red to the positive and negative poles of the diode to be tested respectively.
4. The meter displays the forward bias value of the diode to be tested. If the polarity of the test lead is reversed, the meter will display "OL".

A normal diode still produces a forward voltage drop of 0.5V to 0.8V; the reverse bias voltage reading depend on the variation in electric resistance of other channels between two pen-shaped meters.

3.2.4 Beep continuity test

 **To avoid the meter or the measured equipment from damage, do not attempt a beep continuity test unless the operator has already cut off all power sources for the circuit to be measured and fully discharged all high-voltage capacitors.**

Steps for a continuity test:

1. Turn the rotary switch to the position  .
2. Connect the test lead in black and test lead in red to COM input socket and V/Ω input socket respectively.
3. Use another two ends of the test lead to measure the resistance of the circuit to be measured. If the measured distance is no more than 40Ω , the sensor LED (green indicator) will be on and the beeper will sound continuously. If the measured resistance is between 40Ω and 60Ω , the sensor LED (red indicator) will be on.

3.2.5 Capacitance measurement

 **To avoid the meter or the measured equipment from damage, do not attempt a capacitance measurement unless the**

operator has already cut off all power sources for the circuit to be measured and fully discharged all high-voltage capacitors. Use the DC voltage position to determine that all capacitors have been discharged.

The measuring ranges for the capacitance of this meter are 6.000nF, 60.00nF, 600.0nF, 6.000 μ F, 60.00 μ F and 600.0 μ F,6mF,100mF.

Measurement of capacitance:

1. Turn the rotary switch to the position 100mF.
2. Connect the test leads in black and in red to COM input socket and  input socket respectively.
3. Use another two ends of the test lead to measure the capacitance of the capacitor to be measured, and capture the measured value on LCD screen.

Note:

- The measurement of a large capacitance requires a given period of stabilization of reading.
- To avoid damage to the meter, the measurement of a capacitor with polarities requires much attention to its polarity.

3.2.6 Frequency measurement



To avoid any electric shock and/or damage to the meter, do not attempt a frequency measurement if the voltage is over 250V for DC current or AC current(valid value).

Frequency measurement:

1. Turn the rotary switch to the position HZ%.
2. Connect the test leads in black and in red to COM input socket and Hz input socket respectively.
3. Use another two ends of the test lead to measure the frequency of the circuit to be measured.
4. Read the measured frequency on LCD screen.

3.2.7 Current measurement



Do not attempt a measurement on the current in a circuit, if when the voltage between the open-circuit voltage and the ground is over 250V. If the fuse is blown at the moment of measurement, you are likely to damage the meter or get

yourself hurt.

To avoid any damage to the meter or equipment to be measured, do not attempt a current measurement unless you have examined the meter's protective tube. In attempting a measurement, you should use the correct input sockets, function positions and measuring ranges. When a test lead is inserted into the current input socket, do not put the other end of the test lead in parallel connection with any circuit.

The meter provides DC current measuring ranges as follows: 60 μ A, 6mA, 60.00mA, 600.0mA and 10.00A; and AC current measuring ranges: 60.00mA, 600.0mA, and 10.00A.

Measurement of current:

1. Turn the rotary switch to the appropriate position.
2. Connect the test lead in black to COM input socket. Connect the test lead in red to a mA input socket when the measured current is less than 600mA; connect the test lead in red to a 10A input socket when the measured current is 600mA~10A.
3. Disconnection of the circuit to be measured Connect the test lead in black to the end of disconnected circuit (the voltage is lower) and connect the test lead in red to the end of the disconnected circuit (voltage is higher).
4. Connect the power to the circuit and capture the displayed reading. If the display unit only shows "OL", it means the input is over the selected measuring range. At this moment, turn the rotary switch to a higher measuring range.

3.2.8 NCV test (non-contact voltage detection)

Turn the rotary switch to NCV position, and place the top of the meter approach the conductor. If the meter detects the AC voltage, the indicators for signal density (high, medium and low) will be on in accordance with the detected density, while the beeper will sounds alarms at different frequencies.

Note:

1: Voltage may still remain in the absence of any indication. The operator shall not rely on non-contact voltage detector to check the presence of voltage. The detection operation may be affected by various factors, including socket design, insulation thickness and type.

2. When the voltage is input into the meter's input terminal, the voltage sensor LED may be on as a result of induced voltage.
3. External sources of interference (like flashlight and motor) may trigger non-contact voltage detection.

3.2.9 Live line test

1. Turn the rotary switch to the position Live.
2. Connect the test lead in red to Live input socket.
3. When a single test lead is inserted into jack L of power socket or approaches a live conductor, if the meter detects AC voltage, the meter's indicator for the intensity (high, medium and low) of induced voltage signal will be on and the beeper sounds alarms for different intensities.

3.2.10 Measuring temperature

Put the range switch at the gear of °C/°F. Insert the red plug of the thermocouple into the end of °C, and insert the black plug of the thermocouple into COM socket. Directly read the temperature value from the display screen after the reading is stable.

Notes: The maximum measuring temperature for the K-type thermocouple dispatched at random is 250°C, and its instant measuring value can reach 300°C.

4. Technical parameters

4.1 Overall parameters

- Operating environment:
600V CAT IV and 1000V CAT. III Pollution level: 2
Altitude < 2000 m
Working temperature & humidity: 0~40°C (The requirements will not be considered when temperature is less than 10°C and relative humidity is below 80%).
Storage temperature & humidity: -10~60°C (batteries shall be removed when RH is below 70%).
- Coefficient of temperature: $0.1 \times \text{accuracy} / ^\circ\text{C}$ (<18°C or >28°C).
- Allowable max voltage between terminal to be measured and ground:
1000V DC or 750V AC (valid value)
- Protection of protective tube: mA position: protective tube FF
600mA/1000V; A position protective tube FF 10A/1000V
- Rotation rate: approximately 3 revolutions/second

- Display unit: 6000 counts displayed on LCD screen. Automatically display the symbol for unit in accordance with measurement function position.
- Outrange indication: the LCD screen will display "OL".
- Battery Low indication: "E+" will appear when the battery's voltage is below the normal working voltage.
- Input polarity indication: "-" will automatically appear.
- Power: 4 x 1.5V AA battery
- Dimensions: 192 mm(L)×89mm(W)×55mm(H).
- Weight: approximately 340g (not included batteries or test leads)

4.2 Precision indicator

Accuracy: \pm (% reading + digit)

The accuracy warranty will run for 1 year upon the ex-factory date.

Reference conditions: ambient temperature is between 18°C and 28°C and relative humidity is no more than 80%.

4.2.1 DC voltage

Measuring range	Resolution	Accuracy
600mV	0.1mV	\pm (0.5% Reading + 3 digits)
6V	1mV	
60V	10mV	
600V	100mV	
1000V	1V	\pm (0.5% Reading + 3 digits)

Input impedance: 10M Ω

Maximal input voltage: 1000Vdc or 750Vac valid value

4.2.2 AC voltage

Measuring range	Resolution	Accuracy
6V	1mV	\pm (0.8% readings +3 digits)
60V	10mV	
600V	100mV	\pm (1% readings +10 digits)
750V	1V	

Input impedance: 10M Ω

Maximal input voltage: 1000Vdc or 750Vac valid value

Frequency response: 40Hz-1kHz True RMS

4.2.3 Frequency

Measuring range	Resolution	Accuracy
9.999Hz	0.001Hz	± (1% Reading + +3 digits)
99.99Hz	0.01Hz	
999.9Hz	0.1Hz	
9.999KHz	0.001 KHz	
99.99KHz	0.01 KHz	
999.9KHz	0.1 KHz	
9.999MHz	0.001MHz	

Input voltage range: 200mV-10V ac valid value

Overload protection: 600V DC/AC

4.2.4 Electric resistance

Measuring range	Resolution	Accuracy
600Ω	0.1Ω	±(0.8% Reading + 3 digits)
6kΩ	1Ω	
60kΩ	10Ω	
600kΩ	100Ω	
6MΩ	1kΩ	
60MΩ	10kΩ	±(1.2% Reading + 30 digits)

Overload protection: 600V DC/AC

Open-circuit voltage: 1V

4.2.5 Diode

Functions	Measuring range	Resolution	Testing conditions
Diode test ➔	0-3V	0.001V	Forward DC current: approximately 1mA; Open-circuit voltage: approximately 3.2V. The display unit shows the approximate value of the diode's forward voltage drop.

Overload protection: 600V DC/AC

4.2.6 Beeper continuity

Functions	Measuring range	Resolution	Description	Testing conditions
o1))	600Ω	0.1Ω	When the built-in beeper sounds and the accompanying red indicator is on, the measured resistance shall not be over 30.Ω The red indicator will be on when the resistance is 40Ω-60Ω.	Open-circuit voltage: approximately 1V

Overload protection: 600V DC/AC

4.2.7 Capacitor

Measuring range	Resolution	Accuracy
6nF	0.001nF	± (4.0% Reading +3 digits)
60nF	0.01nF	
600nF	0.1nF	
6μF	1nF	
60μF	10nF	
600μF	100nF	
6mF	1μF	
100mF	0.01mF	± (5.0% Reading + 3 digits)

Overload protection: 600V DC/AC

4.2.8 DC current

Measuring range	Resolution	Accuracy
60μA	0.01μA	±(0.8% Reading + 3 digits)
6mA	0.001mA	
60mA	0.01mA	
600mA	0.1mA	
10.00A	10mA	±(1.2% Reading + 3 digits)

Overload protection:

protective tube for mA measuring range (FF600mA/1000V) ;

protective tube for 10A measuring range (FF10A/1000V) .

Maximal input voltage: mA position: 600mA DC/AC (valid value);

10A position: 10A DC/AC (valid value)

When the measured current is over 5A, the duration of continuous measurement shall not be over 10 seconds. The current measurement shall be carried out 1 minute after the completion of previous measurement.

4.2.9 AC current

Measuring range	Resolution	Accuracy
60mA	0.01mA	±(1% Reading + 3 digits)
600mA	0.1mA	
10A	10mA	±(1.5% Reading + 3 digits)

Overload protection:

protective tube for mA measuring range (FF600mA/1000V) ;

protective tube for 10A measuring range (FF10A/1000V) .

Maximal input voltage: mA position: 600mA DC/AC (valid value);

10A position: 10A DC/AC (valid value)

When the measured current is over 5A, the duration of continuous measurement shall not be over 15 seconds. The current measurement shall be carried out 1 minute after the completion of previous measurement.

Frequency response: 40Hz-1kHz True RMS

4.2.10 Temperature (depends on different model, only for the instruments with it)

Measuring range	Resolution	Accuracy	
°C	1°C	-20°C~1000°C	± (1.0%+3) reading
°F	1°F	-4°F~ 1832°F	± (1.0%+3) reading

Overload protection: 600V DC/AC

5. Meter maintenance

This section provides the basic information on maintenance, including the descriptions about replacement of protective tubes and batteries. Do not attempt the meter maintenance unless you are experienced in maintenance and have read the information on calibration, performance test and maintenance. .

5.1 General maintenance



To avoid any electric shock or damage to the meter, do not attempt to clean the inside of the meter. You must remove the line connecting a test lead to input signals, before opening the case or battery cover.

You must regularly use damp cloth and a small quantity of detergent to clean the meter's shell. Don't attempt the use of any abrading or chemical solvent.

The dirty or damp input socket may affect reading.

Steps for cleaning input sockets:

- Disenable the meter and pull all test leads out of the input socket.
- Clean up all dirty substances on sockets.
- Use a new cotton ball with a detergent or lubricant to clean each socket, because lubricant can prevent the socket vulnerable to dampness from pollution.

5.2 Battery & fuse replacement



To avoid any electric shock or personal injury as a result of incorrect reading, replace batteries once the symbol "E+" appear on the display unit.

Only the designated fuse (600mA/1000V, 10A/1000V quick-acting fuse) can be used.

To avoid any electric shock or personal injury, don't attempt to open the battery cover to replace batteries, unless you have already powered off the device and carried out an examination to ensure that the test lead has been disconnected from the circuit to be measured.

Battery replacement:

1. Turn off the power of the meter.
2. Disconnect all test leads from the input socket.
3. Use a screwdriver to remove the screw of battery cover.
4. Take off the battery cover.
5. Take out the old batteries carefully and replace with 4 pcs 1.5 V AA new batteries.
6. Fix the battery cover.

Fuse replacement

When fuse is blown, replace with the same type of fuse.

1. Turn off the power of the meter and take out the holster.
2. Use a screwdriver to remove the screw of back cover.
3. Take off the back cover.
4. Remove the blown fuse and replace with the same type of fuse
5. Screw the back cover
6. Put the holster back.

Pro'sKit[®] MT-1707 3-5/6 真有效值電表使用手冊

1 概述

Pro'sKit MT- 1707 3-5/6 數位多用表是根據國際電工安全標準 IEC—61010 對電子測量儀器和掌上型數位多用表的安全要求而設計生產的。

符合 IEC61010 的 600V CAT IV、1000V CAT. III 和污染程度 2 要求。使用本儀錶前，請仔細閱讀使用說明書並請注意有關安全工作準則。

1.1 安全資訊

■ 安全說明

- 使用本儀錶時，使用者必須遵守關於以下兩方面的全部標準安全規程：
 - A. 防止電擊方面的安全規程
 - B. 防止錯誤使用儀表方面的安全規程
- 為保證人身安全，請使用隨表附上的測試筆。在使用前，檢查並確保它們是完好的。

■ 安全注意事項

- 在電磁干擾比較大的設備附近使用儀錶，儀錶的讀數會不穩定，甚至可能會產生較大的誤差。
- 當儀錶或表筆外觀破損時，請不要使用。
- 若不正確使用儀錶，儀錶提供的安全功能可能會失效。
- 在裸露的導體或匯流排周圍工作時，必須極其小心。
- 禁止在爆炸性的氣體、蒸汽或灰塵附近使用本儀錶。
- 必須使用正確的輸入端、功能、量程來進行測量。
- 輸入值切勿超過每個量程所規定的輸入極限值，以防損壞儀錶。
- 當儀錶已連接到被測線路時，切勿觸摸沒有使用的輸入端。
- 當被測電壓超過 60Vdc 或 30Vac 有效值時，小心操作防止電擊。

- 使用測試筆測量時，應將手指放在測試筆的護環後面。
- 在轉換量程之前，必須保證測試筆已經離開被測電路。
- 對於所有的直流功能，為避免由於可能的不正確讀數而導致電擊的危險，請先使用交流功能來確認是否有任何交流電壓的存在。然後，選擇一個等於或大於交流電壓的直流電壓量程。
- 在進行電阻、二極體、電容測量或通斷測試前，必須先切斷被測電路電源，並將被測電路裡所有的高壓電容器放電。
- 不可在帶電的電路上測量電阻或進行通斷測試。
- 在進行電流測量前，應先檢查儀錶的保險管。在儀錶連接到被測電路之前，應先將被測電路的電源關閉。
- 在進行電視機維修或測量電源轉換電路時，必須小心被測電路中的高幅電壓脈衝以免損壞儀錶。
- 本儀錶使用 4 顆 1.5V AA 電池供電，電池必須正確安裝在儀錶的電池盒內。
- 當電池欠壓符號  出現時，應立即更換電池。電池電量不足會使儀錶讀數錯誤，從而可能導致電擊或人身傷害。
- 在進行測量類別 III 電壓測量時不可超過 1000V；進行測量類別 IV 電壓測量時不可超過 600V。
- 儀錶的外殼（或外殼的一部分）被拆下時，切勿使用儀錶。

■ **安全符號：** 儀錶表體及使用說明書中使用的符號：



警告，重要的安全標誌，使用前應參閱使用說明書。錯誤使用可能致設備或它的部件的損壞。



AC（交流）



DC（直流）



交流電或直流電



接地



雙重絕緣保護



保險絲



符合歐盟（European Union）指令



高壓警告

CAT. III III 類 1000 V 過電壓保護

CAT. IV IV 類 600 V 過電壓保護

■ 安全的保養習慣

- 打開儀錶外殼或拆下電池蓋時，應先拔出測試筆。
- 維修儀錶時，必須使用指定的替換零部件。
- 在打開儀錶前，必須斷開一切有關的電源，同時也必須確保您沒帶有靜電以免損壞儀錶的元器件。
- 儀錶的校準以及維修操作必須由專業人員操作。
- 打開儀錶外殼時，必須注意到儀錶內的一些電容即使在儀錶關閉電源以後還保存著危險的電壓。
- 如果觀察到儀錶有任何異常，該儀錶應立即停止使用並送維修。並確保在檢查合格前不能被使用。
- 當長時間不用時，請將電池取下，並避免存放於高溫高濕的地方。

1.2 輸入保護措施

- 在進行電壓測量時，可承受最高輸入電壓是直流電壓 1000V 或交流電壓 750V。
- 在進行頻率、電阻、通斷和二極體測量時，可承受不超過交流電壓 600V 或等效的有效值電壓。
- 在進行 μA 電流、mA 電流測量時，通過保險管（F600mA/1000V）進行保護。

2 儀錶示意說明

本儀錶是一款具有真有效值的掌上型測量數位萬用表。具有大螢幕液晶數字顯示屏，並有背光源，使用者容易讀數。具有超載保護和電池欠壓指示。無論專業人員、工廠、學校、愛好者或家庭使用，均為一台理想的多功能儀錶。

2.1 儀表示意圖

- ①. 非接觸電壓感應區 ②. 非接觸電壓指示燈 ③. 液晶顯示器
④. 按鍵 ⑤. 旋轉開關 ⑥. 輸入插座

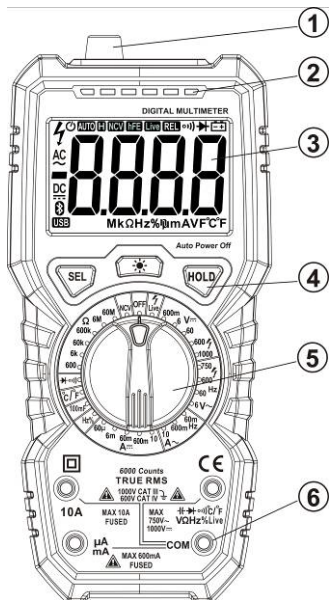

2.2 顯示器符號說明

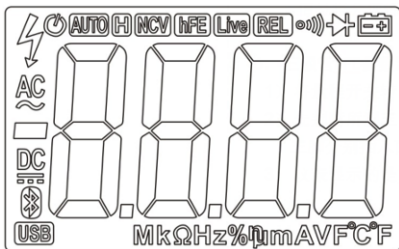



符号	說明
	電池欠壓指示符/電池電量低。 為避免錯誤的讀數而導致遭受到電擊或人身傷害，本電池低壓符號顯示出現時，應儘快更換電池。
	自動關機功能指示符。
	高壓警告符
	輸入極性指示負極
	交流輸入指示。
	直流輸入指示。
	儀錶在通斷測試模式下。
	儀錶在二極體測試模式下。
	表示自動量程模式。
	儀錶在資料保持模式下。
°C、°F	溫度單位(°C: 攝氏; °F: 華氏)
%	占空比
NCV	儀錶在非接觸交流電壓偵測模式下。
Live	儀錶在零火線判斷模式下。
V, mV	V: 伏特，電壓的單位 mV: 毫伏， 1×10^{-3} 或 0.001 伏特
A, mA, μ A	A: 安培，電流的單位。 mA: 毫安培， 1×10^{-3} 或 0.001 安培。 μ A: 微安， 1×10^{-6} 或 0.000001 安培。
Ω , k Ω , M Ω	Ω : 歐姆，電阻的單位。 k Ω : 千歐，1000 歐姆。 M Ω : 兆歐，1,000,000 歐姆。
MkHz	Hz: 赫茲，頻率單位。 kHz: 千赫茲， 1×10^3 赫茲。 MHz: 兆赫茲， 1×10^6 或 1000 千赫茲。
mF, μ F, nF	F: 法拉，電容的單位 mF: 毫法， 1×10^{-3} 或 0.001 法拉。 μ F: 微法， 1×10^{-6} 或 0.000001 法拉 nF: 納法， 1×10^{-9} 或 0.000000001 法拉

2.3 功能按鍵說明

按 鍵	功 能 說 明
SEL	功能選擇鍵 溫度測量檔：選擇°C或°F模式。 頻率測量檔：選擇頻率（HZ）或占空比（%）測量模式。 交流電壓檔和交流電流檔：在交流電壓或交流電流測量狀態下，按該鍵可以選擇電壓/頻率或電流/頻率測量模式。
HOLD	按此鍵保持該瞬間的測量值。再按下就取消該功能。
	按此鍵，背光燈和 LED 照明燈同時點亮，再次此鍵，關掉背光和 LED 照明燈。若不按此鍵，15 秒後自動關閉。

2.4 輸入插座說明

輸入插座	描 述
COM	所有測量的公共輸入端與黑色測試筆或專用多功能測試座的公共輸出插頭相連。
   °C/°F VΩ Hz% lives	電容、二極體測量、蜂鳴器通斷測試、溫度測量、電壓、電阻、頻率、占空比及零火線判斷的正輸入端（與紅色測試筆相連）。
μA mA	電流 μA、mA 正輸入端（與紅色測試筆相連）。
10A	電流 10A 的正輸入端（與紅色測試筆相連）。

2.5 附件

使用說明書	一本
測試表筆	一副
感溫探頭	一個

3 操作指南

3.1 常規操作

■ 讀數保持模式

- 讀數保持模式可以將目前的讀數保持在顯示器上。改變測量功能

檔位或再按一次 HOLD 鍵都可以退出讀數保持模式。

- 按一次“H”鍵，讀數將被保持且“H”符號同時顯示在液晶顯示器上。

- 再按一次“H”鍵將使儀錶恢復到正常測量狀態。

■ 背光及 LED 照明功能

儀錶設有背光及 LED 照明功能，以方便用戶在照明條件較暗的地方準確的讀取測量結果。開啟或關閉背光及 LED 照明操作如下：

- 按  鍵，開啟背光及 LED 照明。

- 再按  鍵，手動關閉背光及 LED 照明；或者約 15 秒後自動關閉背光及 LED 照明。

■ 自動關機功能

開機約 15 分鐘後若無任何操作，儀錶將會發出滴滴聲音提示將自動切斷電源，進入休眠狀態。在自動關機模式下按任何按鍵都可以重新開機。

3.2 測量指南

■ 測量交流和直流電壓



不可測量任何高於 1000V 直流或 750V 交流有效值的電壓，以防遭到電擊和/或損壞儀錶。

不可在公共端和大地間施加超過 1000V 直流或 750V 交流有效值的電壓以防遭到電擊和/或損壞儀錶。

本儀錶的直流電壓量程為：600.0mV、6.000V、60.00V、600.0V 和 1000V；
交流電壓量程為：6.000V、60.00V、600.0V 和 750V。

● 測量交流或直流電壓：

1. 將旋轉開關旋至 $\overline{\text{V}}$ 或者 $\sim\text{V}$ 檔位。
2. 分別把黑色測試筆和紅色測試筆連接到 COM 輸入插座和 V 輸入插座。
3. 用測試筆另兩端測量待測電路的電壓值。（與待測電路並聯）
4. 液晶顯示器讀取測量電壓值。在測量直流電壓時，顯示器會同時顯示紅色表筆所連接的電壓極性。

注意：

- 在直流 600mV 及交流 6V 量程，即使沒有輸入或連接測試筆，儀錶也會有數字顯示，在這種情況下，短路“V-Ω”和“COM”端一下，使儀錶

顯示回零。

- 在交流電壓功能下，按 **SEL** 鍵可測量交流電壓源的頻率，請參閱測量頻率。
- 使用此儀錶測量的交流電壓值為**真有效值**（均方根）。對於正弦波和其他波形（沒有直流偏移），如方波、三角波和階梯波，這些測量是準確的。

■ 測量電阻



為避免儀錶或被測設備的損壞，測量電阻前，應切斷被測電路的所有電源並將所有高壓電容器充分放電。

電阻的單位是歐姆（ Ω ）

本儀錶的電阻量程為 600.0 Ω 、6.000k Ω 、60.00k Ω 、600.0k Ω 、6.000M Ω 、60.00M Ω 。

● 測量電阻：

1. 將旋轉開關旋至合適檔位。
2. 分別把黑色測試筆和紅色測試筆連接到 **COM** 輸入插座和 **V/ Ω** 輸入插座。
3. 用測試筆另兩端測量待測電路的電阻值。
4. 由液晶顯示器讀取測量電阻值。

5. 注意：

6. 在電路上所測量到的電阻值通常會和電阻的額定值有所不同。
7. 在測量低電阻時，為了測量準確請先短路兩表筆讀出表筆短路的電阻值，在測量被測電阻後需減去該電阻值。
8. 在 60M Ω 檔，要幾秒鐘後讀數才能穩定。這對於高阻值測量來說是正常的。
9. 當儀錶開路時，顯示器將顯示“OL”，表示測量值超出量程範圍。

■ 二極體測試



為避免儀錶或被測設備的損壞，在二極體測量以前，應切斷被測電路的所有電源並將所有高壓電容器充分放電。

在電路外測試一個二極體：

1. 將旋轉開關轉至  檔位，按 **SEL** 鍵選擇  測試。

2. 分別把黑色測試筆和紅色測試筆連接到 COM 輸入插座和 V/Ω 輸入插座。
3. 分別把黑色測試筆和紅色測試筆連接到被測二極體的負極和正極。
4. 儀錶將顯示被測二極體的正向偏壓值。如果測試筆極性接反，儀錶將顯示“OL”。
5. 在電路裡，正常的二極體仍應產生 0.5V 到 0.8V 的正向壓降；但反向偏壓的讀數將取決於兩表筆之間其它通道的電阻值變化。

■ 蜂鳴通斷測試

 為避免儀錶被測設備的損壞，在蜂鳴通斷測試以前，應切斷被測電路的所有電源並將所有高壓電容器充分放電。

進行通斷測試：

1. 將旋轉開關轉至  檔位。
2. 分別把黑色測試筆和紅色測試筆連接到 COM 輸入插座和 V/Ω 輸入插座。
3. 把測試筆另兩端測量被測電路的電阻，如被測電路電阻不大於約 40Ω 時，感應指示燈（綠燈）點亮，蜂鳴器會發出連續響聲。如果被測電阻大於 40Ω 小於 60Ω 時，感應指示燈（紅燈）點亮。

■ 電容測量

 為避免儀錶或被測設備的損壞，在測量電容以前，應切斷被測電路的所有電源並將所有高壓電容器充分放電。用直流電壓檔確定電容器均已被放電。

本儀錶的電容量程為 6.000nF、60.00nF、600.0nF、6.000μF、60.00μF 和 600.0μF,6mF,100mF。

● 測量電容：

1. 將旋轉開關轉至 100mF 檔位。
2. 分別把黑色測試筆和紅色測試筆連接到 COM 輸入插座和  輸入插座。
3. 用測試筆另兩端測量待測電容的電容值並從液晶顯示器讀取測量值。

注意：

- 測量大電容時，穩定讀數需要一定時間。
- 測量有極性電容時，要注意對應極性，避免損壞儀錶。

■ 頻率測量

 不可測量任何高於 250V 直流或交流有效值的電壓的頻率以防遭到電擊和/或損壞儀錶。

測量頻率：

1. 將旋轉開關轉至 HZ% 檔位。
2. 分別把黑色測試筆和紅色測試筆連接到 COM 輸入插座和 Hz 輸入插座。
3. 用測試筆另兩端測量待測電路的頻率值。
4. 由液晶顯示器讀取頻率值。

■ 電流測量

 當開路電壓對地之間的電壓超過 250V 時，切勿嘗試在電路上進行電流測量。如果測量時保險管被燒斷，您可能會損壞儀錶或傷害到您自己。

為避免儀錶或被測設備的損壞，進行電流測量以前，請先檢查儀錶的保險管。測量時，應使用正確的輸入插座、功能檔和量程。當測試筆被插在電流輸入插座上的時候，切勿把測試筆另一端並聯跨接到任何電路上

本儀錶的直流電流量程為 60 μ A、6.000mA、60.00mA、600.0mA 和 10.00A 交流電流量程為 60.00mA、600.0mA 和 10.00A；

● 測量電流：

1. 將旋轉開關轉至合適檔位。
2. 把黑色測試筆連接到 COM 輸入插座。如被测電流小於 600mA 時將紅色測試筆連接到 mA 輸入插座；如被测電流在 600mA~10A 間，將紅色測試筆連接到 10A 輸入插座。
3. 斷開待測的電路。把黑色測試筆連接到被斷開的電路(其電壓比較低)的一端，把紅色測試筆連接到被斷開的電路(其電壓比較高)的一端。
4. 接上電路的電源，然後讀出顯示的讀數。如果顯示器只顯示“OL”，這表示輸入超過所選量程，旋轉開關應置於更高量程。

■ NCV 測試（非接觸電壓偵測）

將旋轉開關旋轉 NCV 檔位元，將儀錶頂部貼近導體，如果儀錶探測到交流電壓，儀錶根據探測到的信號強度，點亮相應信號強度指示燈（高、中、低），同時蜂鳴器發出不同頻率的報警聲。

注意：

- 即使沒有指示，電壓仍然可能存在。不要依靠非接觸電壓探測器來

判斷導線是否存在電壓。探測操作可能會受到插座設計、絕緣厚度及類型不同等因素的影響。

- 當儀錶輸入端子輸入電壓時，由於感應電壓的存在，電壓感應指示燈亦可能會亮。
- 外部環境的干擾源（如閃光燈，馬達等），可能會誤觸發非接觸電壓探測。

■ 火線測試

1. 將旋轉開關轉至 Live 檔位元。
2. 把紅色測試筆連接到 V 輸入插座。
3. 單筆筆插入電源插座 L 插孔或靠近帶電導線，如果儀錶探測到交流電壓，會根據探測到的信號強度，儀錶感應電壓信號強度指示燈（高中低）點亮，蜂鳴器發出不同強度的報警聲。

■ 溫度測量

將量程開關置於 °C/°F 檔，熱電偶的紅色插頭插入 °C 端，黑色插頭插入 COM 插孔即可。待讀數穩定，可直接從顯示幕上讀取溫度值。

注意：隨機配送的 K 型熱電偶最高測量溫度為 250°C，暫態測量可達 300°C。

4 技術指標

4.1 綜合指標

■ 使用環境條件:

- 600V CAT IV 及 1000V CAT. III 污染等級：2
- 海拔高度 < 2000 m。
- 工作環境溫濕度：0~40 °C (<80% RH, <10°C 時不考慮)。
- 儲存環境溫濕度：-10~60°C (<70% RH, 取掉電池)。
- 溫度係數：0.1×準確度/°C (<18 °C 或 >28 °C)。
- 測量端和大地之間允許的最大電壓：1000V 直流或 750V 交流有效值
- 保險管保護：mA 檔：保險管 FF 600mA/1000V ;A 檔保險管 FF 10A/1000V
- 轉換速率：約 3 次/秒
- 顯示器：6000 counts 液晶顯示器顯示。按照測量功能檔位元自動顯示單位符號。
- 超量程指示：液晶顯示器顯示“OL”。
- 電池低壓指示：當電池電壓低於正常工作電壓時，“ ”顯示。
- 輸入極性指示：自動顯示“-”號。
- 電源：4 x 1.5V AA 電池（出貨不含）
- 尺寸：192(L)×89(W)×55mm(H); 重量：約 340g（不含表筆、電池）。

4.2 精度指標

準確度：± (%讀數+字)，保證期自出廠之日起一年。

基準條件：環境溫度 18°C至 28°C、相對濕度不大於 80%。

■ 直流電壓

量程	解析度	準確度
600mV	0.1mV	± (0.5% 讀數 +3 字)
6V	1mV	
60V	10mV	
600V	100mV	
1000V	1V	± (0.5% 讀數 +3 字)

● 輸入阻抗：10MΩ

● 最大輸入電壓：1000V DC 或 750V AC 有效值。

■ 交流電壓

量程	解析度	準確度
6V	1mV	±(0.8%讀數+3字)
60V	10mV	
600V	100mV	± (1% 讀數 +10 字)
750V	1V	

● 輸入阻抗：10MΩ

● 最大輸入電壓：1000V DC 或 750V AC 有效值。

● 頻率回應：40Hz-1KHz 真有效值

■ 頻率

量程	解析度	準確度
9.999Hz	0.001Hz	± (1%讀數+3字)
99.99Hz	0.01Hz	
999.9Hz	0.1Hz	
9.999KHz	0.001 KHz	
99.99KHz	0.01 KHz	
999.9KHz	0.1 KHz	
9.999MHz	0.001MHz	

● 輸入電壓範圍：200mV-10V AC 有效值

● 超載保護：600V DC/AC

■ 電阻

量程	解析度	準確度
600Ω	0.1Ω	±(0.8% 讀數 +3 字)
6kΩ	1Ω	
60kΩ	10Ω	
600kΩ	100Ω	
6MΩ	1kΩ	
60MΩ	10kΩ	±(1.2% 讀數 +30 字)

- 超載保護：600V DC/AC
- 開路電壓：1 V

■ 二極體

功能	量程	解析度	測試條件
二極體測試 ➔	0-3V	0.001V	正向直流電流：約 1mA；開路電壓：約 3.2V。 顯示器顯示二極體正向壓降的近似值。

- 超載保護：600V DC/AC

■ 蜂鳴通斷

功能	量程	解析度	說明	測試條件
o))	600Ω	0.1Ω	當內置蜂鳴器發聲並伴隨綠色指示燈點亮時，被測電阻不大於約 30Ω。在約 40Ω-60Ω，紅色指示燈點亮。	開路電壓：約 1V

- 超載保護：600V DC/AC

■ 電容

量程	解析度	準確度
6nF	0.001nF	± (4.0%讀數+30 字)
60nF	0.01nF	
600nF	0.1nF	± (4.0%讀數+3 字)
6μF	1nF	
60μF	10nF	
600μF	100nF	
6mF	1uF	± (5.0%讀數+3 字)
100mF	0.01mF	

- 超載保護：600V DC/AC

■ 直流電流

量程	解析度	準確度
60 μ A	0.01 μ A	\pm (0.8% 讀數 +3 字)
6mA	0.001mA	
60mA	0.01mA	
600mA	0.1mA	
10.00A	10mA	\pm (1.2% 讀數 +3 字)

- 超載保護：mA 量程保險管 (FF600mA/1000V)；10A 量程保險管 (FF10A/1000V)。
- 最大輸入電流：mA 檔：600mA 直流或交流有效值；
10A 檔：10A 直流或交流有效值
- 當測量電流大於 5A 時，連續測量時間不能長於 10 秒鐘，測量後須停止電流測量 1 分鐘。

■ 交流電流

量程	解析度	準確度
60mA	0.01mA	\pm (1% 讀數 +3 字)
600mA	0.1mA	
10A	10mA	\pm (1.5% 讀數 +3 字)

- 超載保護：mA 量程保險管 (FF600mA/1000V)；10A 量程保險管 (FF10A/1000V)。
- 最大輸入電流：mA 檔：600mA 直流或交流有效值；
10A 檔：10A 直流或交流有效值
- 當測量電流大於 5A 時，連續測量時間不長於 15 秒鐘，測量後須停止電流測量 1 分鐘。
- 頻率回應：40Hz-1KHz，真有效值

■ 溫度

量程	解析度	準確度
$^{\circ}$ C	1 $^{\circ}$ C	-20 $^{\circ}$ C ~ 1000 $^{\circ}$ C \pm (1.0%+3) 讀數
$^{\circ}$ F	1 $^{\circ}$ F	-4 $^{\circ}$ F ~ 1832 $^{\circ}$ F \pm (1.0%+3) 讀數

- 超載保護：600VDC/AC

5 儀錶維護

本節提供基本的維護資料，包括更換保險管和更換電池的說明。除非您是有經驗的維修人員且有相關的校準、性能測試以及維修資料，否則不要嘗試去維修本儀錶

5.1 一般維護



為避免受到電擊或損壞儀錶，不可弄濕儀錶內部。在打開外殼或電池蓋前，必須把測試筆和輸入信號的連接線拆除。

定期使用濕布和少量洗滌劑清潔儀錶外殼，請勿用研磨劑或化學溶劑。輸入插座如果弄髒或潮濕可能會影響讀數。

■ 要清潔輸入插座：

- 關閉儀錶，並將所有測試筆從輸入插座中拔出。
- 清除插座上的所有髒物。
- 用新的棉花球沾上清潔劑或潤滑劑，清理每個插座，潤滑劑能
- 防止和濕氣有關的插座污染。

5.2 更換電池及保險絲



為避免錯誤的讀數而導致受到電擊或人身傷害，儀錶顯示器出現“”符號時，應馬上更換電池。

只能使用指定的保險絲(600mA/100V,10A/1000V 速熔保險絲)

為避免受到電擊或人身傷害，在打開電池蓋更換新電池之前，應關機並檢查測試筆已從測量電路斷開。

更換電池或保險絲：

1. 關斷儀錶電源。
2. 將所有測試筆從輸入插座中拔出。

更換電池

1. 用十字螺絲刀取出固定電池蓋的螺釘。
2. 取下電池蓋。
3. 拿掉舊電池，換上新的 4 x 1.5V AA 電池。
4. 裝上電池蓋，上緊螺釘。

更換保險絲

1. 拿掉防護膠套。
2. 用十字螺絲刀取出固定儀錶後蓋的螺釘。
3. 取下儀錶後蓋。
4. 拿掉損壞的保險絲，換上符合規格的新保險絲。
5. 裝上儀錶後蓋，旋緊螺絲。
6. 裝上防護膠套。
- 7.

Pro'sKit®

寶工實業股份有限公司
PROKIT'S INDUSTRIES CO., LTD

©2016 Prokit's Industries Co., LTD. All rights reserved 2016001(C)



**Test Equipment
Depot**

1-800-517-8431

99 Washington Street
Melrose, MA 02176
Phone 781-665-1400
Toll Free 1-800-517-8431



Visit us at www.TestEquipmentDepot.com