

Guide to low voltage motor testing

Megger[®]
Baker Instruments

**Test Equipment
Depot**

1-800-517-8431

99 Washington Street
Melrose, MA 02176
Phone 781-665-1400
Toll Free 1-800-517-8431



Visit us at www.TestEquipmentDepot.com



Contents

Introduction	5
Motor types	6
DC Motor	6
DC Motor Types – Series; Shunt; Compound; Permanent Magnet	6
DC Motor Types - Series	7
DC Motor Types - Shunt	8
DC Motor Types - Compound	8
DC Motor Types - Permanent Magnet	9
Advantages of a DC motor	10
AC Motor	10
AC Motors Types	10
Star Configuration	11
Delta configuration	12
Star vs Delta configuration	12
Why perform Motor Tests?	13
What problems create the need for a test?	13
Testing and Diagnostics	14
Trending of test data	17
Megger Baker MTR105 – The Tests	18
Insulation resistance	19
Spot or Timed insulation resistance test	20
Polarisation Index (PI)	21
Dielectric Absorption Ratio (DAR)	22
Temperature correction	24
Guard Terminal	25
Three phase test	28
Voltmeter	28
Phase rotation	28
Continuity	28
Diode test	29

Digital Low Resistance Ohmmeter (DLRO)	29
Motor Direction of Rotation test	30
Inductance	32
Capacitance	32
Temperature measurement	32
Megger Baker MTR105 Overview	33
Description	33
Features	33
Applications	34
Safety	34
Insulation resistance tests	34
Voltmeter	35
Continuity (Resistance) tests	35
DLRO Four wire Kelvin low resistance	35
Motor Direction of Rotation test	35
Inductance, Capacitance and Resistance meter (LCR)	36
Temperature	36
Display	36
Guard Terminal	36
Storage and download of results	36
Instrument software updates	36
Specifications	37

This is the first in a series of information booklets that will support electrical testing in the benchmarking, maintenance and repair of rotating machines. This guide uses the specific tests of the Megger Baker MTR105 to demonstrate the importance and application of these tests for low voltage machines rated up to 2300 volts, as described in IEEE Standards which are listed at the end of this document.

Introduction

Electric motors are made up of a multitude of components that when combined and assembled into a motor have to endure extreme electrical and mechanical operating stress as well as varying environmental conditions during their service life. To prevent premature failure, regular testing is necessary to ensure reliable operation and, importantly, to extend the motor's service life. Electrical testing usually consists of Insulation Resistance (Meg Ohm $M\Omega$) tests and a Low Resistance tests (Milli-Ohm $m\Omega$). These tests are essential in determining the health of a motor, however, not all faults or early detection of potential faults can be detected with these tests. Performing a suite of different test types where each test provides a 'piece of the puzzle' helps to build up to a clearer picture which is essential in determining the of the health of the electric motor.

Motor types

There are two main types of motors “ac” and “dc”. A Direct Current (dc) motor has direct current connected to the windings and rotor (armature) to produce rotation. An Alternating Current (ac) motor has alternating current connected to the stator (stationary windings). In both types this produces rotation on the rotor (armature) through a magnetic field.

DC Motor

DC Motor Types – Series; Shunt; Compound; Permanent Magnet

A simplified representation of a DC motor showing a single loop of the armature

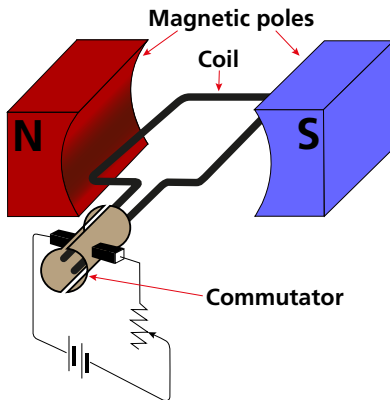

Fig 1: *Simplified DC motor*

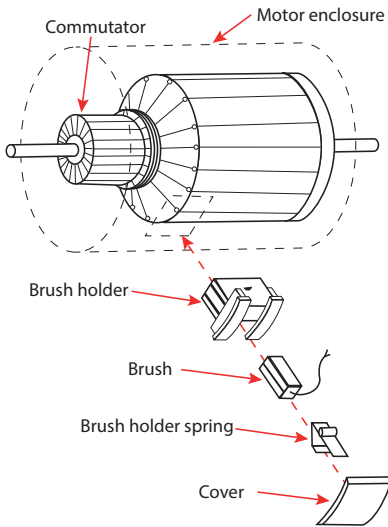

Fig 2: A typical representation of a DC motor showing an exploded view of the brush components and with multiple loops making up the armature.

DC Motor Types - Series

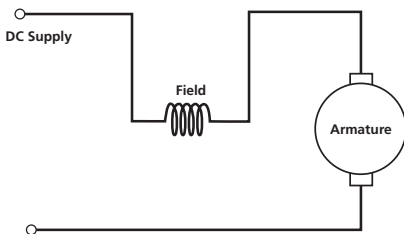

Fig 3: Series excited DC motor

An electric motor powered by direct current where the field windings are connected in series to the armature windings.

DC Motor Types - Shunt

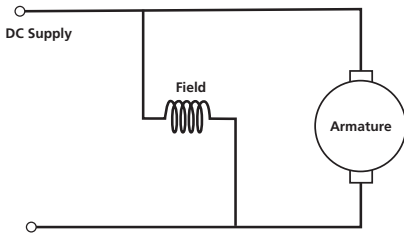

Fig 4: *Shunt excited DC motor*

An electric motor powered by direct current where the field windings are connected in parallel to the armature windings. This allows both coils to be powered by the same source.

DC Motor Types - Compound

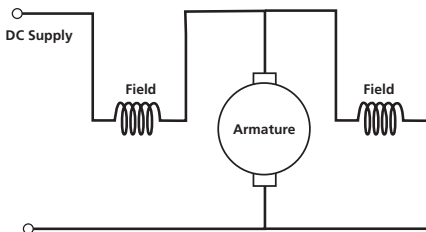

Fig 5: *Cumulatively compound excited DC motor*

The dc compound motor is a combination of the series motor and the shunt motor. It has a series field winding that is connected in series with the armature and a shunt field that is in parallel with the armature

DC Motor Types - Permanent Magnet

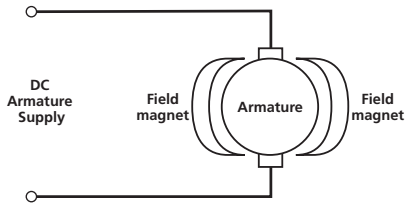

Fig 6: *Permanent magnet DC motor*

A DC Motor whose poles are made of permanent magnets is known as a Permanent Magnet DC (PMDC) Motor. The magnets are radially magnetized and are mounted on the inner periphery of the cylindrical steel stator. The stator of the motor serves as a return path for the magnetic flux.

Advantages of a DC motor

Used in applications where only a dc voltage source is available. The motor speed is easily controlled by change to the applied voltage. They are mainly used where high torque is required at low speed and constant high torque is needed at variable speed ranges.

AC Motor

AC Motors Types

- Single phase (shaded pole; split-phase; capacitor start; capacitor-run; capacitor-start and run).
- Three phase

Advantages over dc – used in all other applications and due to the brush-less design less maintenance is required.

Advantages of three phase over single phase motors – more energy efficient and have no capacitors or centrifugal switches to drive or maintain

This guide will focus on three phase AC motors as they represent the majority of motors in use today. The diagram shows a typical construction of a three phase motor with an open configuration i.e. the motor is not configured for Star or Delta configuration and all three phases are isolated. See 'Star configuration' and 'Delta configuration' for additional details.

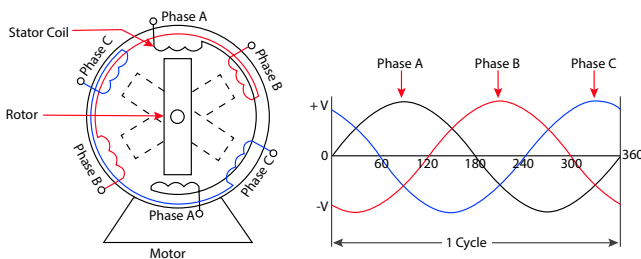

Fig 7: 3 phase motor

Star Configuration

In a STAR configuration the three phases are connected together to form a neutral point.

- Line current is equal to the Phase current
- Allowed supply voltage is higher (than Delta)
- The phase voltage is $1/\sqrt{3}$ of the line voltage
 - Voltage per phase is lower (than Delta)
 - Lower inrush current
 - Less power

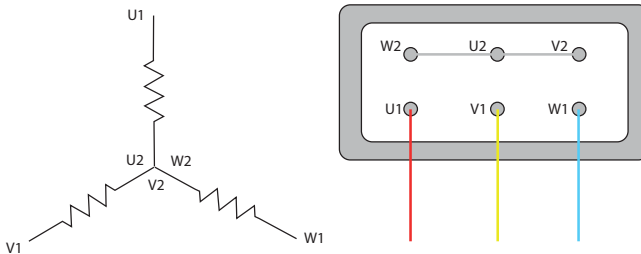

Fig 8: Star connection of motor winding

Delta configuration

In a DELTA configuration the opposite ends of the three phases are connected together where the end of a phase is connected to the start of another phase.

- The line voltage is equal to the phase voltage
- Allowed supply voltage is lower (than Star)
- The line voltage is equal to the phase voltage
 - Voltage per phase is higher (than Star)
 - Higher inrush current
 - More power

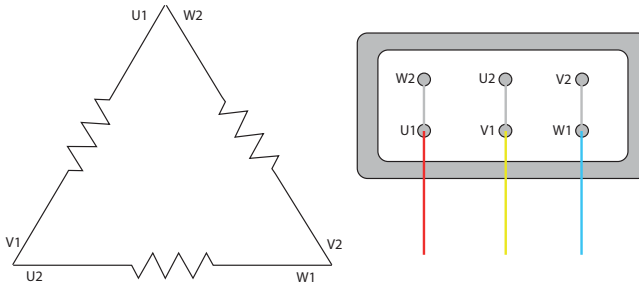

Fig 9: Delta connection of motor winding

Star vs Delta configuration

Delta is typically used where a high starting torque is required. Star is used where a low starting current is required.

Why perform Motor Tests?

Early detection of faults during manufacture of new motors is vital. This is important at both component and assembly levels. Detection of faults, for in service motors, as soon as they begin to develop results in a reduction of 'downtime' and reduced repair costs.

Early detection and correct diagnosis of developing faults will help determine the condition of in-service equipment. We can then predict when maintenance should be performed or arrange routine maintenance, i.e. a time-based preventive maintenance schedule, to provide sufficient time for the planned controlled shut down of the affected process. Both predictive and preventative maintenance can reduce financial losses, maintain production levels and avoid catastrophic consequences.

What problems create the need for a test?

When motors and generators are new, the electrical system should be in a very good condition. Additionally rotating machine manufacturers have continually improved the quality of their products. Nevertheless, even today, motors and generators are subject to many changes to conditions which can cause these products to fail, i.e. mechanical damage, vibration, excessive heat or cold, dirt, oil, corrosive vapours, moisture from processes, or just the humidity of the air. In varying degrees these factors are at work and as time goes on, combined with the electrical stresses that exist, create a harsh environment for daily operation. As pin holes or cracks develop, moisture and foreign matter penetrate the surfaces of insulation, providing a low resistance path for leakage current.

Once started, the different enemies tend to aid each other, permitting excessive current through the insulation. Sometimes the drop in insulation resistance is sudden, as when equipment is flooded. Usually, however, it drops gradually, giving plenty of warning, if tested periodically. Such tests permit planned reconditioning before service failure. If not tested periodically, a motor with poor insulation, for example, may not only be dangerous to touch when voltage is applied, but also be subject to burn out. What was good insulation has become a partial conductor.

Testing and Diagnostics

Electrical testing and diagnostics can be segmented to two main categories:

- Static (De-Energised) Electrical Testing –
 - When the supply to the machine is isolated, electrical tests are carried out to find faults or to provide data which can be used as a benchmark or trended over time.
- Dynamic (Energised) Electrical Testing –
 - This will include live testing, analytics and compliment static testing

Although static tests are discussed, there are three important dynamic tests which have been included, these are supply voltage, frequency and phase rotation.

The industrial and utility market is driven by the simple need to keep production moving without interruption. There are many other reasons to test rotating machines, these include:

- Safety - people and property
- Compliance with standards and regulations
- Reduce downtime
- Save money / time – plan downtime to repair or replace
- Save energy
- Maintain service to the end user
- Maintain critical services
- Maintain performance / productivity
- Trend data to predict failure
- Lifetime (or end of life) planning
- Research, development, design, prototyping
- During and after manufacture
- On receipt
- Prior to installation
- Commissioning
- Maintenance
- After servicing
- Fault finding in situ
- Fault finding on the bench
- During the repair process

- After the repair
- Recommissioning
- Again maintenance
 - Reactive
 - This is the “run it till it breaks” maintenance mode.
 - No actions or efforts are taken to maintain the equipment as the designer originally intended to ensure design life is reached.
 - Corrective
 - ‘Repair of equipment/machinery in order to bring it back to original operating condition’.
 - Preventative
 - ‘Schedule of planned maintenance actions aimed at the prevention of breakdowns and failures’.
 - Primary goal - Preserve and enhance equipment reliability.
 - Predictive
 - ‘Techniques that help determine the condition of in-service equipment in order to predict when maintenance should be performed’. Primary goal – minimize disruption of normal system operations, while allowing for budgeted, scheduled repairs.
 - The examination of trended data is a crucial aspect of PdM.

At each point in the lifespan of a motor there are opportunities to test, retest, trend, predict, observe and diagnose normal or unusual behaviour which can extend its duty cycle. Although most engineering maintenance systems and procedures have strict regimes a vast amount of data is often missed.

All the maintenance methods fit into the product lifecycle which can be seen as the 'bathtub curve'. The Observed Failure Rate is made up of the 3 failure curves

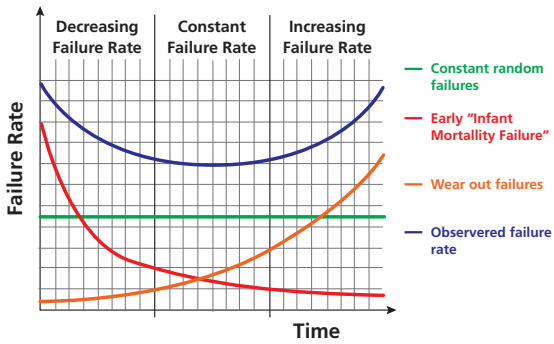

Fig 10: Motor failure rate

Trending of test data

The collection of data is extensively used across many disciplines and has immense value when analysed over time to predict trends. When used for rotating machines this analysis of electrical testing data can be used to reveal downward trends towards the imminent failure of the machine. Systematic trending of test data is a key element of a high quality electrical maintenance program and recognising a degrading trend strongly indicates impending trouble, especially if the trend is accelerating.

These tests include insulation resistance, leakage current, capacitance and inductance. To provide meaningful information the trending program must be structured to consider the effects of external factors which affect the measured results but which are irrelevant to the actual condition of machines health and reliability.

For example insulation resistance readings which are taken at varying temperatures must be corrected to a base temperature before comparison with one another.

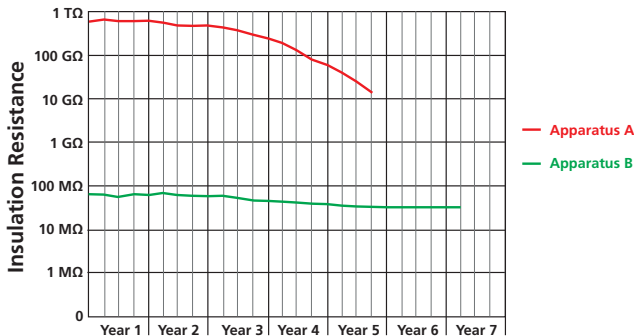

Fig 11: Insulation resistance rate graph

Taking insulation resistance as an example, Apparatus 'A' in year 5 has an insulation resistance of about 20 GΩ which normally would be accepted as an excellent result. But following the downward trend which started at year 1 with an insulation resistance of about 1 TΩ it can be seen that the insulation is on an accelerating path towards failure.

However Apparatus 'B' in year 7 has a much lower insulation resistance by comparison at 50 MΩ and the trend from year 1 which initially had a reading of 90 MΩ reveals a much more gradual trend indicating that this machine is in much better condition than Apparatus 'A'.

Megger Baker MTR105 – The Tests

- Insulation resistance up to 1000 volts
 - Spot
 - Timed
 - Polarisation Index
 - Dielectric Absorption Ratio
 - Temperature correction
 - Guard Terminal
 - Three Phase test - Fully automated phase to phase Insulation Resistance measurement of all three phases
- Voltmeter
 - Voltage – ac; dc; TRMS;
 - Frequency
 - Phase Rotation
- Continuity
 - Diode test
 - Low resistance
- DLRO – Digital Low Resistance Ohmmeter
- Motor Direction of Rotation
- LCR meter
 - Inductance
 - Capacitance
 - Resistance
- Temperature measurement



Insulation resistance

See Megger's guide to insulation resistance testing 'A Stitch in Time'

Before going into the different tests it is time to mention the different types of test current used for insulation resistance testing. When the button is pressed to start a test, the high voltage is produced and a current is generated. This current is made up from 3 elements.

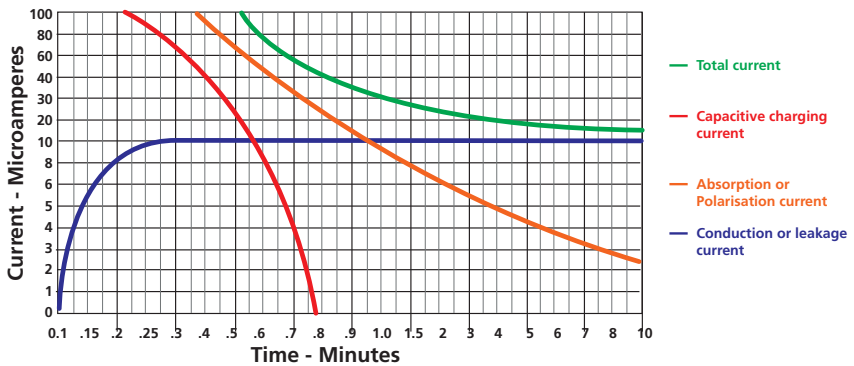

Fig 12: Current elements under test

Although these currents are generally considered together as the total test current, they behave differently.

The capacitive charging current starts quite high but drops quickly as the device under test charges in much the same way as a capacitor.

The absorption or polarisation current also starts high but decays over a longer period of time as the molecules of the insulation of the device under test line up to oppose the flow of current, this polarisation may take some time to occur.

Conduction or leakage current normally begins at a low level, settling to a constant value it is the current that travels through the insulation and flows along the surface.

We see this as one current that can be measured with an ammeter but using Ohms Law we can represent this as a resistance.

The IEEE offers the following guidance for insulation resistance test voltages with respect to the rated line-to-line voltage for three-phase ac machines, line-to-ground voltage for single-phase machines and rated direct voltage for dc machines or field windings.

Winding rated Voltage	Test Voltage (DC)
<1000	500
1000 – 2500	500 - 1000
2501 – 5000	1000 - 2500
5001 – 12000	2500 - 5000
>12000	5000 - 10000

Table 1: Rated voltage and corresponding test voltage

Spot or Timed insulation resistance test

The Spot test still remains the basic insulation resistance test that most engineers will use to test equipment although it has evolved over time.

How long does the test last? That is up to the user, but the Spot test usually runs for about 60 seconds. The value of a quick test can't be under stated but, as we will see, this test combined with the other types of insulation resistance test provides a more reliable indication of the state of the motor.

Insulation resistance should be approximately 1 MΩ for each 1,000 volts of operating voltage, with a minimum value of 1 MΩ. For example, a motor rated at 2,400 volts should have a minimum insulation resistance of 2.4 MΩ. In practice, the readings are normally are considerably above this minimum value in new equipment or when insulation is in good condition.

Polarisation Index (PI)

This test is similar to the DAR test, but the times at which the readings are taken are much longer. This allows the device under test to be fully charged and the insulation to be polarised

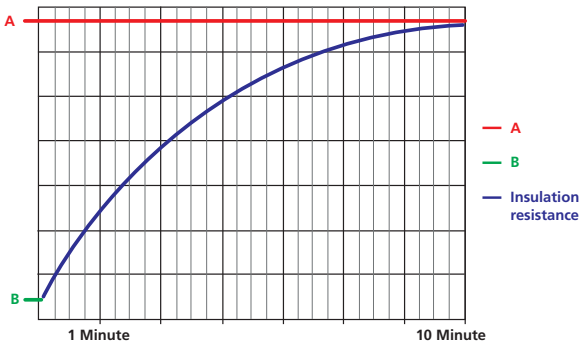

Fig 13: Ratio of time resistance readings over 10 minutes

Usually carried out over 10 minutes the PI is calculated in a similar way to DAR.

In this test, the voltage is applied and IR measurements are taken after 1 minute and 10 minutes.

The Polarisation Index or PI is calculated as $PI = R_{10} \div R_1$

Table 2 shows the condition of the insulation.

Polarisation Index	Insulation Condition
<1	Dangerous
1.0 – 2.0 ***	Questionable
2.0 – 4.0	Good
>4 **	Excellent

Table 2: Condition of Insulation Indicated by Polarisation Index

*These values must be considered tentative and relative - subject to experience with the time-resistance method over a period of time.

**In some cases, with motors, values approximately 20% higher than shown here indicate a dry brittle winding which will fail under shock conditions or during starts. For preventive maintenance, the motor winding should be cleaned, treated and dried to restore winding flexibility.

***These results would be satisfactory for equipment with very low capacitance such as short runs of house wiring.

Why do we need to use this test?

The PI test provides a relative and not absolute measurement. It is a self-contained evaluation of the condition of the insulation and can be used independently or with historical PI measurements for trending. It indicates insulation quality in 10 minutes, which is an advantage when working on large pieces of equipment which can take an hour to charge for an insulation measurement reading. The PI reading shows up moisture ingress, contamination and insulation degradation in a specific time-resistance test.

IEEE 43-2000 states “If the R1 value (at 40 °C) is greater than 5000 MΩ, the P.I. may be ambiguous and can be disregarded”.

Dielectric Absorption Ratio (DAR)

The ratio of two time-resistance readings is called a dielectric absorption ratio. It is useful in recording information about insulation.

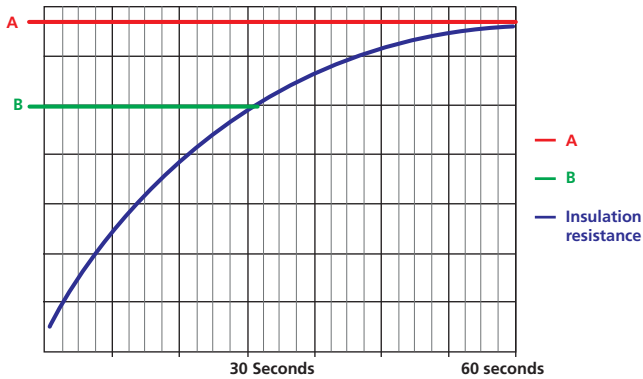

Fig 14: Ratio of time resistance readings over 60 seconds

The dielectric absorption ratio (DAR) is calculated as: $DAR = R60 \div R30$. The ratio is indicative of the condition of the insulation using Table 3.

DAR	Insulation Condition
<1	Dangerous
1.0 – 1.4	Questionable
1.4 – 1.6 **	Good
>1.6	Excellent

Table 3: Condition of Insulation Indicated by Dielectric Absorption Ratios

*These values must be considered tentative and relative - subject to experience with the time-resistance method over a period of time.

**In some cases, with motors, values approximately 20% higher than shown here indicate a dry brittle winding which will fail under shock conditions or during starts. For preventive maintenance, the motor winding should be cleaned, treated and dried to restore winding flexibility.

Why do we need to use this test?

It is a quick test to determine the health of the insulation and a DAR of 1.4 or greater, in pre-1970 insulation systems, is considered acceptable. Otherwise, trending is required. Reference IEEE Std 43-2000.

- Used for equipment with “thin” insulation
- Used on materials with a low absorption current – e.g. Polyethylene

Temperature correction

Insulation resistance values differ considerably at various temperatures, so in order to trend IR values over a long period it is important to correct the IR measurement to a common temperature for IEEE this is 40C.

Temp		Rotating Equip		CABLES							
YC	YF	Class A	Class B	Oil-filled transformers	Code Natural	Code GR-S	Performance	Heat Resist. and Perform. GR-S	Ozone resist natural GR-S	Varnished cambric	Impregnated paper
0	32	0.21	0.40	0.25	0.25	0.12	0.47	0.42	0.14	0.10	0.28
5	41	0.31	0.31	0.36	0.40	0.23	0.60	0.56	0.26	0.20	0.43
10	50	0.45	0.45	0.50	0.61	0.46	0.76	0.73	0.49	0.43	0.64
15.6	60	0.71	0.71	0.74	1.00	1.00	1.00	1.00	1.00	1.00	1.00
20	68	1.00	1.00	1.00	1.47	1.83	1.24	1.28	1.75	1.94	1.43
25	77	1.48	1.25	1.40	2.27	3.67	1.58	1.68	3.29	4.08	2.17
30	86	2.20	1.58	1.98	3.52	7.32	2.00	2.24	6.20	8.62	3.20
35	95	3.24	2.00	2.80	5.45	14.60	2.55	2.93	11.65	18.20	4.77
40	104	4.80	2.50	3.95	8.45	29.20	3.26	3.85	25.00	38.50	7.15
45	113	7.10	3.15	5.60	13.10	54.00	4.15	5.08	41.40	81.00	10.70
50	122	10.45	3.98	7.85	20.00	116.00	5.29	6.72	78.00	170.00	16.00
55	131	15.50	5.00	11.20			6.72	8.83		345.00	24.00
60	140	22.80	6.30	15.85			8.58	11.62		755.00	36.00
65	149	34.00	7.90	22.40				15.40			
70	158	50.00	10.00	31.75				20.30			
75	167	74.00	12.60	44.70				26.60			

Table 4: Temperature correction factors For Rotating Machines Class A and Class B. Corrected to 20 YC for rotating equipment and transformers; 15.6 YC for cable.

Guard Terminal

During insulation testing, the resistance path on the outer surface of the insulation material is often not considered. However, this resistance path is an important part of the measurement and can dramatically affect the results. For example, if dirt, contamination or moisture is present on the outer surface of a motor, the surface leakage current can be up to ten times of that flowing through the actual insulation.

When conducting an insulation resistance test, we may note a low test result. Before condemning the item there is one factor that is often not considered, that is surface leakage due to contamination. This may be dust, dirt, oil, grease, metal filings, food products, moisture, rust, even some types of paint and 'protective' coverings may cause problems

The surface leakage needs to be eliminated from the reading and that is where the Guard terminal comes into play.

Note: If there is a high or compliant reading there is no need to use the Guard terminal.

The connection below shows an IR test between L1 and L2.

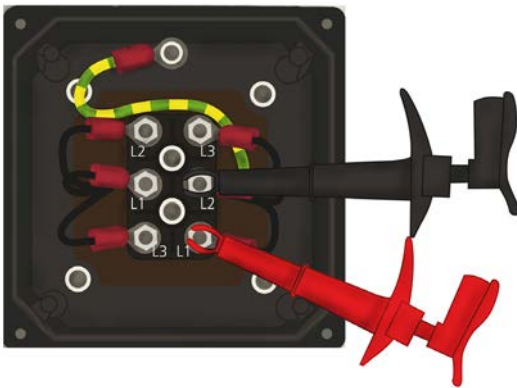

Fig 15: IR test between L1 and L2

If a low phase to phase reading is obtained there is possibly contamination. This is shown here as a low resistance path between U and V phase to ground, where U is equivalent to L1 and V is equivalent to L2.

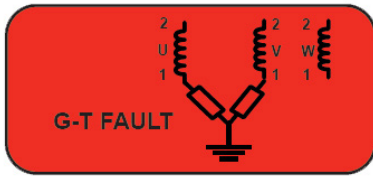

Fig 16: *Low resistance path between U and V to ground*

To guard out this low resistance path connect the GUARD (Blue) test lead to ground

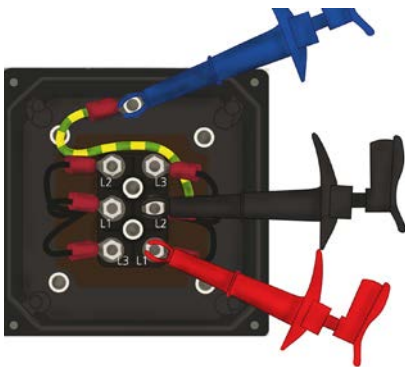

Fig 17: *Guard connected to ground*

If contamination is present the IR reading will increase to the expected level when the GUARD is connected. If no change is noted with the GUARD connected then the insulation has degraded.

Unresolved the contamination can lead to insulation failure and flashover

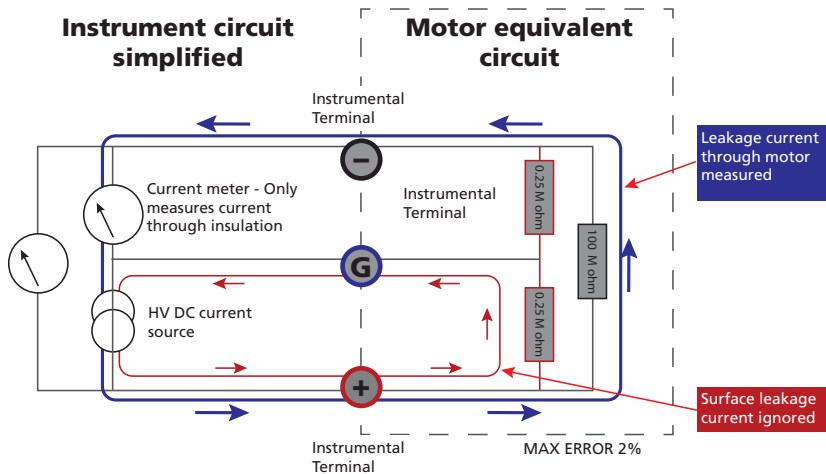

Fig 18: Guard Diagram

The surface leakage is essentially a resistance in parallel with the true insulation resistance of the material under test. By using the guard terminal to perform a 'three-terminal test', the surface leakage current can be ignored. This may be important when high values of resistance are expected, such as motors and supply cables. These tend to have large surface areas that are exposed to contamination, resulting in high surface leakage currents across them.

In addition to the big improvements in the reliability of insulation condition diagnosis and predictive maintenance discussed, the guard terminal is an important diagnostic tool. To carry out this test the windings of the motor must be separated and not left connected in a star or delta configuration.

The amount of current that is surface leakage can be quickly identified simply by performing two tests; one using the guard terminal and one without, then calculating the difference between measurements. With the guard terminal connected, if the insulation resistance is high showing a good level of insulation but considerably lower when the guard terminal is disconnected, the indication is of a parallel path conducting surface leakage across the outer facings of the component between the two terminals.

Why we perform this test?

There have been many instances of poor insulation resistance measurements leading to motors being replaced needlessly, some at huge cost, only to find later, that by employing the guard terminal, they simply needed a good clean!

Three phase test

Similar in operation and performance to the spot test the phase to phase test is a standard test performed on a three phase ac motor to determine the integrity of the insulation of each phase. This test can only be performed when the motor is NOT configured as Star (Y) or Delta. All phases must be isolated.

Voltmeter

Voltage and frequency measurements can be made to ensure that the supply is within that indicated on the nameplate.

Why we perform this test?

Voltage measurements are used to ensure that the supply voltage remains within +/- 10% of the nameplate voltage.

Phase rotation

Phase rotation can be determined to ensure that the supply is compatible with the motor prior to connection and energising.

See Motor direction of rotation.

Why do we need to use this test?

The direction of rotation of the three phase supply voltage is determined to ensure that it matches the direction of rotation of the motor. If the supply direction of rotation does not match the motor direction of rotation, apparatus under the control of the motor will not operate as intended e.g. fans won't blow and pumps won't pump correctly with the required operation.

Continuity

The Continuity test is a 2 wire measurement that involves the output current and the voltage drop measurement combined within the 2 test leads. So the entire resistance of the closed loop (test leads + test piece) is combined in the resistance measurement. NULLing the test leads does not eliminate variation in contact resistance, i.e. NULLing the leads across two points of the test object, then proceeding to test continuity across several other different test points introduces a variance in the contact resistance for all subsequent test points. The contact resistance will almost certainly be different for each test point. The measuring circuit

for a continuity test is low impedance and any variation in the contact resistance will affect the measurement.

The continuity test can quickly identify an unexpectedly high resistance in a conductor which may be due to a break in the conductor or a open connection in a supply cable or faulty control gear.

This is typically performed for each phase i.e. A-a; B-b; C-c;

Continuity tests are also used as a comparative test to determine phase imbalance by comparing the results of all three phases. In a star configured motor each phase is measured i.e. A-Star point; B-Star point; C-Star point. Any significant difference in the resistance measurement will indicate a phase imbalance.

Why we perform this test?

When do we need to measure low resistance?

- Go/No Go
 - Ensure resistance is correct after motor repairs and before installation
- Condition Monitoring
 - Identify unacceptable increase in resistance
- Like Testing
 - Ensure 'like' elements of a system are of similar resistance

Diode test

This test has been included to show the integrity of diodes. It measures the forward and reverse voltage drop over the device. Diode testing - diodes are not usually found on motors but are on alternators and help with polarity control of the excitation circuit.

Digital Low Resistance Ohmmeter (DLRO)

When accurate very low resistance readings are required to be taken, the 4 wire 'kelvin' test configuration is recommended.

Simply stated this test applies a current via 2 of the test leads while measuring the voltage with the other 2 test leads, the result is displayed as a resistance. This test is unaffected by lead or contact resistance and is particularly useful for measuring low winding resistances and the contact resistance of control gear or overloads.

The test can be unidirectional or bidirectional. When testing connection built with dissimilar materials it is recommended to use the bidirectional test.

Why we perform this test?

The DLRO test is performed where an accurate low resistance measurement is required in the $m\Omega$ range.

Motor Direction of Rotation test

Determining the direction of rotation of a motor in relation to the phase rotation of the supply is important, if not crucial for some applications where damage to pumps, compressors or gearboxes can occur. The 'bump' test is often used prior to installation. The motor is momentarily energised and the direction of rotation is noted with regard to the phase connections.

Sometimes there is confusion as to how clockwise and anticlockwise rotation is perceived. The answer lies with DIN EN 60034-8 where the direction of rotation of a motor is defined as follows:

1. The direction of rotation is the direction viewed from the drive end.
2. The drive end is the side with the shaft extension.
3. For machines with two shaft extensions, the drive end is:
 - 3.1. the end with the bigger shaft diameter
 - 3.2. the end on the opposite side to the fan, (if both shaft extensions have the same diameter).

So motors with clockwise rotation turn the shaft clockwise when viewed from the drive end (viewing direction from drive end to non-drive end).

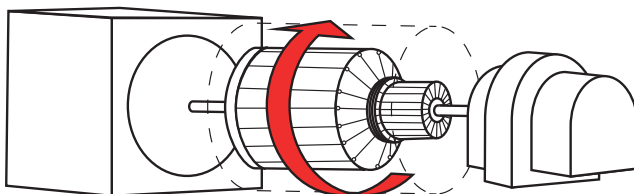

Fig 19: *Clock wise motor*

Motors with counter-clockwise rotation turn the shaft in a counter-clockwise direction when viewed from the drive end (viewing direction from drive end to non-drive end).

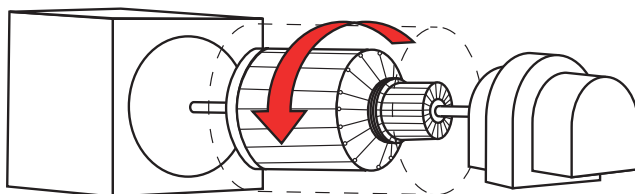

Fig 20: Counter clock wise motor

As the direction of rotation for the motor and driven machine is defined with reference to the respective shaft extension, the motor requires the opposite direction of rotation to that of the driven machine.

That is to say, a counter-clockwise driven machine requires a clockwise-rotating motor and a clockwise driven machine requires a counter-clockwise-rotating motor.

Why we perform this test?

The direction of rotation of the motor is determined to ensure that it matches the direction of rotation of three phase supply voltage. If the motor direction of rotation does not match the supply direction of rotation, apparatus under the control of the motor will not operate as intended e.g. fans won't blow and pumps won't pump correctly.

This test may eliminate the need to perform a 'bump' test. Typically this test is performed on a motor by pressing the start button ON and OFF quickly to determine the motor direction of rotation. The bump test can cause problems when the motor is coupled to apparatus, which is being driven by the motor and is not designed to run backwards. Here severe damage can result to equipment such as screw compressors and some pumps.

Inductance

Phase-to-phase inductance measurements can be used to identify several conditions:

- Poor or incorrect re-work e.g. reversed coil winding leads.
- Power cable faults or power circuit main contacts.
- Air gap eccentricity problems.
- Shorted turns e.g. stator phase-to-phase and coil to coil.
- Rotor porosity and lamination damage.
- Cracked rotor bars or end rings.

Why we perform this test?

Inductance measurements can be useful in determining stator problems, even in cases where the resistance measurements do not show a problem. The winding resistance of each phase can be very low meaning that the amount of resistance per turn may seem negligible. With such a negligible value it would be easy to see how losing a few turns may not be seen by simply measuring resistance. Inductance, however, is exponentially affected by turn changes within windings and therefore provides a more sensitive method to detect changes in stator windings.

Capacitance

Measurement is trended and values to ground increasing over time indicate surface contamination, high humidity, high temperature or insulation breakdown.

Temperature measurement

The temperature of the unit under test is measured in order to perform temperature correction.

Before an insulation resistance test can be carried out with temperature compensation enabled, a temperature measurement must first be taken to establish the temperature of the unit under test.

Megger Baker MTR105 Overview

Description

The MTR105 is a dedicated Static Motor Tester with Megger's tried and trusted suite of insulation resistance tests (IR), plus all the great traditional features and reliability of Megger's testers.



The MTR105 takes the test abilities of Megger's proven IR test instruments adding DLRO four wire Kelvin low resistance test, inductance and capacitance tests to provide a versatile motor tester, all packaged in a robust hand held instrument, which up to now has simply not been available.

Additionally the MTR105 incorporates temperature measurement and compensation (for IR tests), motor direction of rotation plus supply phase rotation tests.

These new test abilities make the MTR105 a real world, versatile, hand held motor test instrument.

The MTR105 comes in an over-moulded case, providing increased protection and robustness, achieving an IP54 weatherproof rating.

Features

- Guard terminal, to eliminate any surface leakage current.
- Detachable test leads with interchangeable clips and probes for different applications.
- Stores test results for up to 256 motors, which can be downloaded to a USB mass storage device.
- Rotary dial control, full graphic display, simple and easy to use.
- Environmental protection to IP54, providing protection against moisture and dust ingress, including the battery and fuse compartment.
- Tough housing: A 'rubber over moulding' combines a tough shock absorbing outer protection with excellent grip, on a strong modified ABS housing, providing a robust case.
- Rechargeable batteries with mains charger kit option.

Applications

- Production tests for new manufactured motors and generators.
- Test repaired and refurbished motors and generators.
- Monitoring and maintenance of in service motors (off line) in the field.

Safety

The MTR105 is designed to be exceptionally safe to use. The fast detecting circuitry reduces the likelihood of damage to the instrument if accidentally connected to live circuits or across phases.

- Meets the international requirements of IEC61010 and IEC61557.
- Live circuit detection and test inhibit on all measurements with user notification (except for direction of rotation measurements).
- User selectable insulation test terminal lockout voltage 25 V, 30 V, 50 V, 75 V (default is 50 V).
- Detection and inhibit functions when the protection fuse has failed.
- Suitable for use on CAT III applications and supply voltages to 600 V.

Insulation resistance tests

- Resistance range 100 Ω up to 200 G Ω .
- Supports PI, DAR, Timed, Three Phase and Temperature Compensation.
- Stabilised insulation test voltage accurate to -0% +2% \pm 2 V, which provides a more accurate test voltage without the risk of over-voltage damage to circuits or components. The output voltage is maintained between 0 and 2% throughout the test range.
- Where a non-standard test voltage is required, a variable range allows the exact test voltage to be selected from 10 V up to 999 V and is subject to the same stabilised output control.
- Dedicated buzzer button either ON, VISUAL or OFF.
- Adjustable buzzer for minimum resistance limit (0.5 M Ω up to 1000 M Ω).
- Buzzer sounds on test pass.

Voltmeter

- Measures ac 10 mV up to 1000 V; dc 0 to 1000 V; TRMS (15 Hz up to 400 Hz).
- Three phase supply and direction of rotation.

Continuity (Resistance) tests

- Single automatic resistance range from 0.01 Ω to 1.0 M Ω .
- Automatic test current selection uses the preferred test current for the load resistance under test (200 mA up to 4 Ω).
- Bi-directional tests option automatically reverses the current without reconnecting leads.
- Lead resistance compensation (NULL) operates up to 10 Ω of resistance.
- Dedicated buzzer switch either ON, VISUAL or OFF.
- Adjustable buzzer for maximum resistance limit (1 Ω to 200 Ω in 12 steps).
- Buzzer sounds on test pass.

DLRO Four wire Kelvin low resistance

- Automatic resistance range from 1 m Ω up to 10 Ω .
- Selectable auto or manual test.
- Bi-direction or single direction.
- Bi-directional tests option automatically reverses the current without reconnecting leads.
- 200 mA test current.

Motor Direction of Rotation test

Tests the direction of rotation of the motor under test and displays the phase sequence on screen.

The connected motor is rotated in one direction and the display shows sequence of the phases of rotation. The motor is next rotated in the opposite direction, the phases are checked again and shown on the display.

Inductance, Capacitance and Resistance meter (LCR)

Auto inductive, capacitive and resistive test. Frequency selectable to 120 Hz or 1000 Hz. In AUTO mode, the MTR105 automatically determines if the main element of the load is inductive, capacitive or resistive and displays the result on screen.

Selectable inductance and capacitance test.

Temperature

Temperature measurement of unit under test, via the supplied thermocouple, allows temperature compensation to be applied in insulation resistance tests.

Temperature measurement of the unit under test, is carried out via a thermocouple, allowing temperature compensation to be applied to insulation resistance tests. A type "T" thermocouple is supplied with the MTR but "J" and "K" type thermocouples can also be used.

Display

Full colour graphic display makes the MTR105 simple to understand and easy to use.

Guard Terminal

The Guard Terminal (G) is a third terminal on the connection panel.

Connection of the guard terminal, on certain applications, provides a return path for parallel leakage currents, which could otherwise create significant errors in the insulation measurement. This is especially so for surface contamination of equipment or cables.

Storage and download of results

Test results can be downloaded to a USB mass storage device, which can be accessed by connecting to a PC or a Laptop running PowerDB.

Instrument software updates

Occasional information bulletins and software updates may be issued on the Megger web site.

Specifications

All quoted accuracies are at 20 °C (68 °F).

Insulation resistance

Volts	Accuracy
50 V	10 G Ω $\pm 2\%$ ± 2 digits $\pm 4.0\%$ per G Ω
100 V	20 G Ω $\pm 2\%$ ± 2 digits $\pm 2.0\%$ per G Ω
250 V	50 G Ω $\pm 2\%$ ± 2 digits $\pm 0.8\%$ per G Ω
500 V	100 G Ω $\pm 2\%$ ± 2 digits $\pm 0.4\%$ per G Ω
1000 V	200 G Ω $\pm 2\%$ ± 2 digits $\pm 0.2\%$ per G Ω

Polarisation index (PI):	10 min / 1 minute ratio
Dielectric absorption ratio (DAR):	User configurable 15 s or 30 s t1 start time with t2 fixed at 60 s
Guard terminal performance	<5% error at 500 k Ω parallel circuit resistance with 100 M Ω load
Resolution	0.1 k Ω
Short circuit/charge current	2 mA +0% -50% (IEC61557-2)
Terminal voltage accuracy	-0% +2% ± 2 V
Test current	1 mA at min. pass value of insulation to a max. of 2 mA
Operation range	0.10 M Ω to 1.0 G Ω (IEC61557-2)
Leakage current display	0.1 μ A resolution 10% (± 3 digits)
Voltage display	$\pm 3\%$ ± 2 digits $\pm 0.5\%$ of rated voltage
Note: Above specifications only apply when high quality silicone leads are being used - as supplied with the instrument.	

Continuity

Measurement	0.01 Ω to 1 M Ω 0 to 1000 k Ω analogue scale)
Accuracy	$\pm 3\%$ ± 2 digits (0 to 99.9 Ω) $\pm 5\%$ ± 2 digits (100 Ω - 500 k Ω)
Test current	200 mA (-0 mA +20 mA) (0.01 Ω - 4 Ω)
Polarity	Single or Dual (factory default) polarity
Lead resistance	Null up to 10 Ω
Selectable current limit	20 mA and 200 mA

Capacitance	
Range	0.1 nF - 1 mF
Accuracy	±5.0% ±2 digits (1 nF - 10 µF)
Voltmeter	
Range	dc: 0 - 1000 V ac: 10 mV - 1000 V TRMS sinusoidal (15 Hz - 400 Hz)
Accuracy	dc: ± 2% ±2 digits (0 - 1000 V) ac: ± 2% ±2 digits (10 mV - 1000 V TRMS)
Frequency range	15 - 400 Hz (50 mV - 1000 V)
Frequency resolution	0.1 Hz
Frequency accuracy	±0.5% ±1 digit
Diode Test	Diode test accuracy: ±2% ±2 digits 0.01 V to 3.00 V
Display range:	0.00 V to 3.00 V
Temperature measurement and compensation	
Thermocouple	Type T (Type K and Type J)
Thermocouple range	-20 °C to 200 °C (4 °F - 392 °F)
Instrument range	-20 °C to 1000 °C (4 °F - 1832 °F)
Instrument resolution	0.1 °C (0.18 °F)
Instrument accuracy	±1.0 °C ±20 digits (1.8 °F). (Basic accuracy stated assumes forward and reverse measurements.)
DLRO four wire Kelvin low resistance	
Test current	200 mA dc
Range	1 mΩ to 10 Ω
Resolution	0.01 mΩ
Accuracy	± 0.25% rdg. ± 10 digits, accuracy stated includes forward and reverse measurements.

Inductance		
Instrument accuracy		
Range	Accuracy	Test Frequency
1 H	$\pm(0.7 \% + (Lx/10000) \% + 5 \text{ digits})$	1 kHz
200 mH	$\pm(1.0 \% + (Lx/10000) \% + 5 \text{ digits})$	120 Hz
	$\pm(0.7 \% + (Lx/10000) \% + 5 \text{ digits})$	1 kHz
20 mH	$\pm(2.0 \% + (Lx/10000) \% + 5 \text{ digits})$	120 Hz
	$\pm(1.2 \% + (Lx/10000) \% + 5 \text{ digits})$	1 kHz
2 mH	$\pm(2.0 \% + (Lx/10000) \% + 5 \text{ digits})$	1 kHz only
Results storage		
Storage capacity	256 motor results (date / time stamped)	
Data download	USB Type A (USB Mass Storage Device)	
Power		
Battery	6 x IEC LR6 1.5 V Alkaline (AA), IEC FR6 1.5 V Lithium (LiFeS ₂), IEC HR6 1.2 V NiMH (rechargeable option).	
Battery life	10 motors per (complete suite of tests at 100 V into 100 M Ω) IEC61557-2 - test cycle, 1200 insulation tests with duty cycle of 5 s testing on 25 sec standby @ 500 V into 0.5 M Ω . IEC61557-4 test cycle, 1200 continuity tests with duty cycle of 5 sec testing on 25 sec standby on 1 Ω resistance.	
Battery charging	Mains battery charger kit.	
Safety protection	IEC61010-1 CAT III 600 V	
EMC	Industrial IEC61326	
Temperature coefficient	<0.1% per °C up to 1 G Ω	

Environment	
Operating temperature range	-10 °C to 50 °C (14 °F to 122 °F)
Storage temperature range	-25 °C to 65 °C (-13 °F to 149 °F)
Humidity	90% RH at 40 °C (104 °F) max.
Calibration temperature	20 °C (68 °F)
Maximum altitude	3000 m (9843 ft.)
IP rating	IP54
Physical	
Display	Full LCD colour screen with user configurable backlight
Languages	English, French, German and Spanish.
Dimensions	228 x 105 x 75 mm (8.98 x 4.1 x 2.95 in)
Weight	1.00 kg (2.2 lbs)
Fuse	x2 500 mA (FF) 1000 V 32 x 6 mm ceramic fuse, high break capacity HBC, 30 kA minimum. Glass fuses must not be installed.
IEE Standards	
IEEE Std 43-2013 IEEE Recommended Practice for Testing Insulation Resistance of Electric Machinery	
IEEE 1415-2006 IEEE Guide for Induction Machinery Maintenance Testing and Failure Analysis	
IEEE 112-2017 IEE Standard Test Procedure for Polyphase Induction Motors and Generators	
NEMA MG-1	



Megger[®]

Baker Instruments

**Test Equipment
Depot**



1-800-517-8431

99 Washington Street
Melrose, MA 02176
Phone 781-665-1400
Toll Free 1-800-517-8431



Visit us at www.TestEquipmentDepot.com

This instrument is manufactured in the United Kingdom.

The company reserves the right to change the specification or design without prior notice.

Megger is a registered trademark

The Bluetooth[®] word mark and logos are registered trademarks owned by Bluetooth SIG, Inc and is used under licence.

**Guide to low voltage Motor Testing--2012-431_en_V01 06 2019
Part No: 2012-431**

© Megger Limited 2019