

# Magnum Pro

CALBRATION PUMPS



## MVP-600

### Pneumatic Calibration Hand Pump

Produces pneumatic pressure and vacuum to check calibration of gauges, switches, transmitters, and recorders. The contoured cushioned handles provide extra comfort while preventing the pump from sliding. The oversized check valve provides smooth operation throughout the output range while the dual o-rings on all pistons ensure zero leakage. Patented Mash proof vent valve comes standard on all MVP-600s (No Needle Valve) and a non-oil based lubricant is used on all moving parts.

**Test Equipment  
Depot**  
1-800-517-8431

5 Commonwealth Ave  
Woburn, MA 01801  
Phone 781-665-1400  
Toll Free 1-800-517-8431

Visit us at [www.TestEquipmentDepot.com](http://www.TestEquipmentDepot.com)

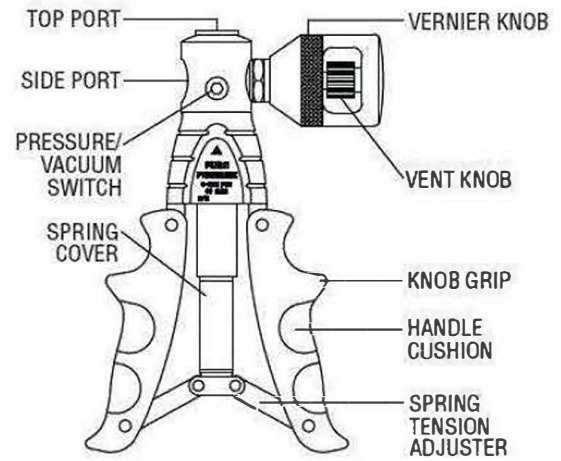
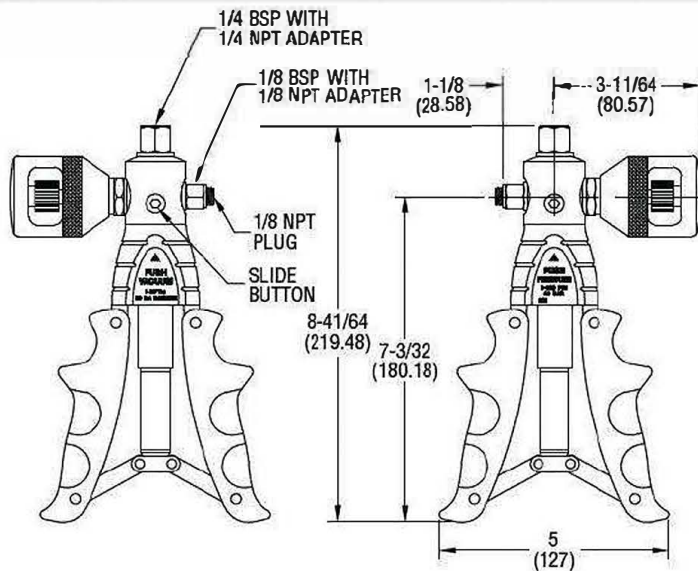

## MVP-600 Pneumatic Calibration Hand Pump

### Specifications

**Media:** Air and compatible gases only  
**Range:** Vacuum to Pressure (28"Hg - 600 PSI / 40 BAR)  
**Connections:** 1/4" NPT/BSP (top) & 1/8" NPT/BSP (side)  
**Materials:** Stainless steel fittings, anodized aluminum housing, plastic/rubber handles, nitrile o-rings.  
**Weight:** 2 lbs (0.91 kg)  
**Warranty:** 2-year "quibble free" warranty.  
 Compatible with all gauges and calibrators. Made in the USA.

### Models

**MVP-600**.....  
**MVP-600KT**.....  
 includes Pump, a black padded canvas case embroidered with orange thread, 2ft non-stretch hose, fittings, additional rubber bonded washers and (2) adaptors.  
**MVP-600WIN**.....  
 includes everything in the MVP-600KT plus Winchester Engineering Model 1 Auto Ranging Digital Gauge™ w/ N.I.S.T. certification and versatile hook.  
**MVP-600WIN-FIT**.....  
 includes everything in the MVP-600WIN plus FasTest universal quick connect kit and coupler for Swagelok tube fittings.  
**MVP-600RK**.....  
 Rebuild Kit for MVP-600 (includes: Bonded Washers, O-Rings, a Schrader Valve, a X-Ring, a Pressure Valve Spring, a Vacuum Valve Spring, a Ring Retain Clip, a Plug Shorty, Krytox High Performance Grease - GPL215, GPL226)

### Maintenance

No routine maintenance is required. A periodic check of system calibration is recommended, however. While the MVP-600 is field serviceable, it is recommended it be returned to East Hills Instruments if repair is needed. Please be sure to fill out an RMA form online prior to shipping.

### Operation

1. Push the pressure/vacuum valve to the desired function (ex: If pressure generation is desired, the pin should be PUSHED IN on the side of the pump housing bearing the label "PRESSURE".
2. Close the vent knob by rotating it away from the pump housing. Please note that there should be a space between the end of the vent knob and the base of the vernier knob.
3. For high pressure operation, back out the vernier knob until the ring on the vernier shaft is visible. Pump to pressurize. Turn the vernier knob towards the pump housing and the pressure should easily be able to reach 600 psi. Note that for a maximum pressure of 600 psi to be reached, the handles should be 3/4" apart at the closest point. The closer the handles are to each other, the lower the amount of pressure that will be able to be generated.
4. To release pressure slowly, turn the vent knob in towards the pump body. To increase or decrease pressure slightly for minor adjustments, use the vernier knob.

### Points to Remember

- Insure all gauges and instruments to be calibrated are disconnected from process pressures before connecting the pump. Do not exceed 600 psi (41 bar) as this is the MVP-600's maximum pressure.
- The MVP-600 has 1/8" and 1/4" BSP ports. In order to use NPT fittings, the required NPT to BSP parallel thread adapters need to be installed (Adapters are Included)
- Do not use thread sealant paste or tape on the male adapters (Female adapters may be sealed with paste or tape). Bonded washers (Included) are required to insure a proper seal. To seal the adapters, simply hand-tighten and snug up with a wrench. Do not over-tighten.
- The MVP-600 utilizes a Schrader valve instead of a needled valve. Thus full open or closed is several turns from the end of the travel. Over-tightening does not increase the seal.

#### WARRANTY/DISCLAIMER

East Hills Instruments, Inc. warrants this unit to be free of defects in materials and workmanship for a period of twenty-five months from date of purchase. East Hills Instruments' warranty adds an additional one month to the normal twenty-four month product warranty to cover handling and shipping time. This insures that all customers receive maximum coverage on each product. If the unit malfunctions, it must be returned to the factory for evaluation. East Hills Instruments will issue a return merchandise authorization (RMA) number. Immediately upon filling out the RMA form on our website. If the product is found to be defective upon examination by the Repair Department, the product will be repaired or replaced at no charge. This warranty also includes damage that may have occurred in the regular activities that the pump is designed for (including accidental dropping of the product, as it is designed to withstand considerable damage). Unauthorized repair attempts or modification of the product may result in voiding of the warranty, and should be avoided.

#### RETURN REQUESTS / INQUIRIES

Direct all warranty and repair requests/inquiries to the East Hills Instruments Customer Service Department. Before returning any product(s), purchaser must obtain an RMA number via our website in order to avoid processing delays. The assigned RMA number should then be marked on the outside of the return package and on any correspondence. The purchaser is responsible for any shipping charges, freight, insurance and proper packaging to prevent breakage in transit.