



Perfect for Routine Moisture Testing

The new OHAUS MB32 features a redesigned housing with stronger material, innovative carbon fiber heating technology and an upgraded load cell for enhanced durability and performance. The easy-to-use MB32 is the perfect choice for routine moisture testing.

Unique Features:

- An LCD with second line display, navigation knob, and intuitive operation system makes for convenient routine moisture testing.
- The new carbon fiber heating technology and upgraded loadcell shortens analysis time, saves power and keeps results accurate and consistent.
- Robust, slim design with a strong housing ensures MB32's durability even in harsh environments.

MB32 Moisture Analyzers

Specifications

Model	MB32
Readability	0.01 % / 0.001 g
Repeatability	0.15 % (3 g sample) 0.02 % (10 g sample)
Moisture Range	0.01 % to 100 % (0.01 % to 1000 % in regain mode)
Recommended MC%	0.5 % to 100 %
Minimum Start Weight	0.5 g
Capacity	90 g
Heating Element	Carbon Fiber
Temperature Range	40 - 180 °C (1 °C incremental)
Drying Programs	Standard, Fast
Method Library	2
Result Storage	1
Switch-off Criteria	3 automatic, timed (1 - 480 mins), manual
ID Management	-
Status Light	-
Operation Instruction	Progress indicator On-screen instruction
Display Type	4" LCD with 2 nd line display
Display Results	MC%, DC%, RG%, time, temperature, weight, Method No.
Language	English, French, German, Italian, Spanish, Portuguese, Chinese, Korean, Japanese, Polish, Turkish
Adjustment	Temperature adjustment (100 °C, 160 °C) External weight adjustment (50 g)
Output	RS232, USB device
Power	120 VAC 50/60 Hz
Operating Temperature Range	10 - 40 °C
Pan Size	Ø 3.5 inch / 90 mm
Dimension	210 x 138 x 352 mm / 8.3 x 5.4 x 13.9 inch
Net Weight	4.3 kg / 9.5 lb
Shipping Weight	6.1 kg / 13.4 lb

Compliance

- **Product Safety:** IEC/EN 61010-1; IEC/EN 61010-2-010; CAN/CSA C22.2 61010-1; CAN/CSA C22.2 61010-2-010; UL 61010-1; UL 61010-2-010
- **Electromagnetic Compatibility:** IEC/EN 61326-1 Class B, Basic environments; FCC Part 15 Class A; Canada ICES-003 Class A
- **Compliance Marks:** CSA; CE; RCM; WEEE

Accessories

Pan Handler, MB32 MB62 MB92	30954234
In-Use Cover, MB32 MB62	30954235
Temperature Calibration Kit	11113857
Scoop	30284477
Aluminum Pan (80)	80850086
Glass Fiber Pads (200)	80850087
Cage, Sample	80252477
Reusable Pan, Set (3), 7mm	80252478
Reusable Pan, Set (3), 14mm	80252479
SF40A Impact Printer	30064203

Outline Dimensions [Test Equipment Depot - 800.517.8431 - TestEquipmentDepot.com](http://TestEquipmentDepot.com)

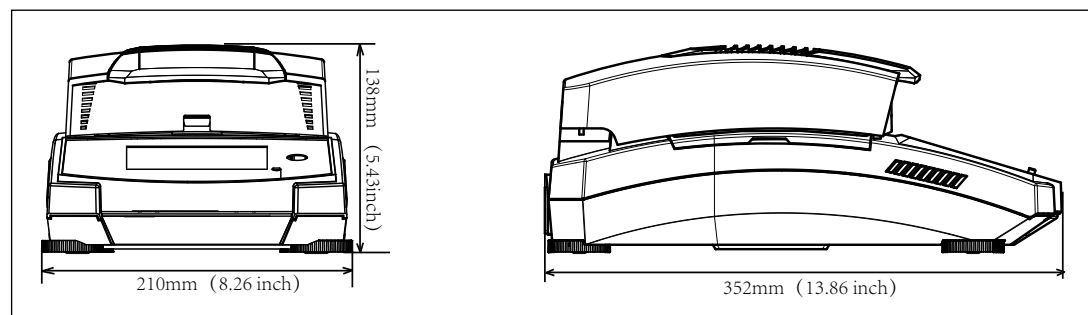

80776942_A 20240618 © Copyright OHAUS Corporation

The management system governing the manufacture of this product is ISO 9001:2015 certified.

