



## ***High Performance Moisture Analysis with Advanced Features for the Most Demanding Application***

The new MB92 features a redesigned housing, innovative carbon fiber heating and upgraded load cell for enhanced durability and performance. Ideal for users demanding a higher level of performance on both the laboratory and production floor, offering greater data security and integrity with password protection.

### ***Unique Features:***

- Robust and durable with the new carbon heating technology and an upgraded full color capacitive touchscreen, MB92 is the perfect choice for users demanding a high level of performance and precision.
- Multiple drying profiles, shut off criteria and methods offer great flexibility in method creation. Enhanced password protection ensures greater data security and integrity.
- A full glass panel and tool-free heating chamber assembly makes cleaning and maintenance easy. Perfect for both the laboratory and the production floor.

# MB92 Moisture Analyzers

## Specifications

Model	MB92
Readability	0.01 % / 0.001 g
Repeatability	0.08 % (3 g sample) 0.015 % (10 g sample)
Moisture Range	0.01 % to 100 % (0.01 % to 1000 % in regain mode)
Recommended MC%	0.5 % to 100 %
Minimum Start Weight	0.5 g
Capacity	90 g
Heating Element	Carbon Fiber
Temperature Range	40 - 200 °C (1 °C incremental)
Drying Programs	Standard, Fast, Ramp, Step
Method Library	20
Result Storage	200
Switch-off Criteria	5 automatic, timed (1 - 480 mins), manual, free
ID Management	Sample Name (Free Defined), Sample ID (Free Defined) and Batch ID (Free Defined)
Status Light	Multi-color status light
Operation Instruction	Live drying curve On-screen instruction
Display Type	4.3" capacitive touch screen
Display Results	MC%, DC%, RG%, time, temperature, weight, method name., drying curve and statistics
Language	English, French, German, Italian, Spanish, Portuguese, Chinese, Korean, Japanese, Polish, Turkish
Adjustment	Temperature adjustment (100 °C, 160 °C) External weight adjustment (50 g)
Output	RS232, USB host, USB device
Power	120 VAC 50/60 Hz
Operating Temperature Range	10 - 40 °C
Pan Size	Ø 3.5 inch / 90 mm
Dimension	210 x 138 x 352 mm / 8.3 x 5.4 x 13.9 inch
Net Weight	4.3 kg / 9.5 lb
Shipping Weight	6.1 kg / 13.4 lb

## Compliance

- **Product Safety:** IEC/EN 61010-1; IEC/EN 61010-2-010; CAN/CSA C22.2 61010-1; CAN/CSA C22.2 61010-2-010; UL 61010-1; UL 61010-2-010
- **Electromagnetic Compatibility:** IEC/EN 61326-1 Class B, Basic environments; FCC Part 15 Class A; Canada ICES-003 Class A
- **Compliance Marks:** CSA; CE; RCM; WEEE

## Accessories

Pan Handler, MB32 MB62 MB92 .....	30954234
In-Use Cover, MB92 .....	30954269
Temperature Calibration Kit .....	11113857
Scoop .....	30284477
Aluminum Pan (80) .....	80850086
Glass Fiber Pads (200) .....	80850087
Cage, Sample .....	80252477
Reusable Pan, Set (3), 7mm .....	80252478
Reusable Pan, Set (3), 14mm .....	80252479
SF40A Impact Printer .....	30064203

## Outline Dimensions [Test Equipment Depot - 800.517.8431 - TestEquipmentDepot.com](http://TestEquipmentDepot.com)

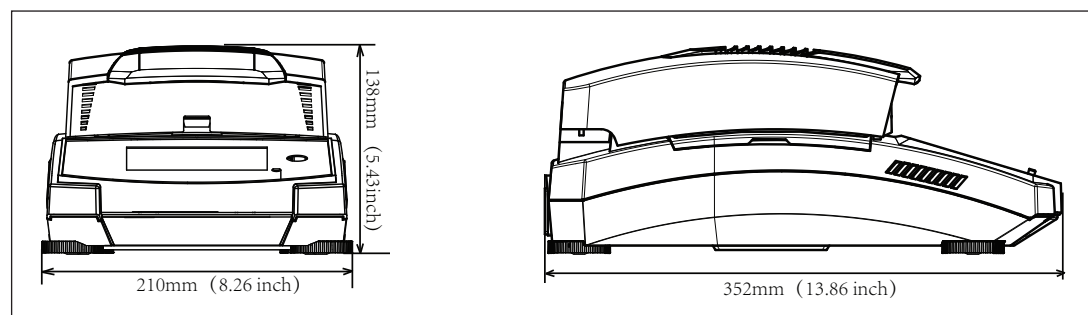

80776918\_A 20240618 © Copyright OHAUS Corporation

*The management system governing the manufacture of this product is ISO 9001:2015 certified.*

