

PB-203A

Powered Proto-Board Instruction Manual

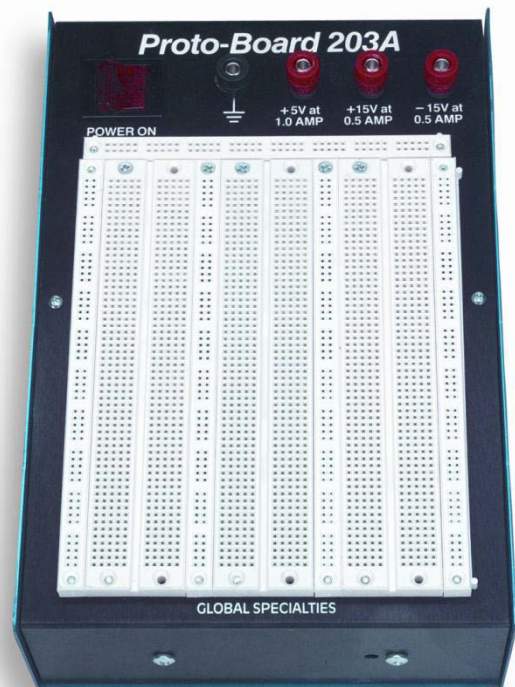



99 Washington Street
Melrose, MA 02176
Phone 781-665-1400
Toll Free 1-800-517-8431

 Visit us at www.TestEquipmentDepot.com

All rights reserved. No Part of this book shall be reproduced, stored in a retrieval system, or transmitted by any means, electronic, mechanical, photocopying recording, or otherwise, without written permission from the publisher. No patent liability is assumed with respect to the use of the information contained herein. While every precaution has been taken in the preparation of this book, the publisher assumes no responsibility for errors or omissions. Neither is any liability assumed for damages resulting from the use of the information contained herein.

Global Specialties specifically warns the user of this instrument that it is intended for use in a classroom or laboratory environment for the purpose of learning and experimentation. When building experimental circuits, it may emit interference that will effect radio and television reception and the user may be required to stop operation until the interference problem is corrected. Home use of this equipment is discouraged since the likelihood of interference is increased by the close proximity of neighbors.

CORRECTIVE MEASURES:

Interference can be reduced by the following practices.

- 1) Install a commercially built RFI power filter in the power line at the point where the cord enters the unit.
- 2) Avoid long wires. They act as antennas.
- 3) If long wires must be used, use shielded cables or twisted pairs which are properly grounded and terminated.

ABOUT GLOBAL SPECIALTIES

Thank you for selecting this Global Specialties product. You won't be disappointed! Since 1973, Global Specialties has been the recognized leader in technical education courses, training equipment and tutorial materials. Our electronics and microcomputer teaching systems have proven to be effective in secondary schools, technical schools, colleges, universities and industrial training departments throughout the world.

We have been leaders in the development of integrated teaching systems and completely packaged courses which include everything required for effective instruction. Comprehensive textbooks and laboratory manuals have been written in a comfortable, non-intimidating style by experienced professional educators, specifically for use with our equipment.

Each course is designed to make selections appropriate for a variety of educational levels and course goals. Instructor's guides, audiovisual aids and other enhancements provide additional teaching efficiency and flexibility.

The central concept upon which we base our entire product line is education through application. We believe that relevant scientific and technical education is best when it involves permitting students to learn by actually doing. Our courses, equipment, instruments and tutorials have been developed with the hands-on approach.

You can count on Global to stand behind every product we sell. We offer a full three-year parts and labor warranty on every assembled product in our line. This means that any Global product which performs improperly can be returned for prompt repair or replacement, with no questions asked. Low per-student cost, durable and trouble-free hardware and proven tutorial materials combine to make technical and scientific courses from Global Specialties the most effective, economical way to upgrade your lab & curriculum.

TABLE OF CONTENTS

Specifications	page 6
Operating Instructions	page 7
Power Supply Description & Schematic Diagram.....	page 9
Using the PB-203A.....	page 10
Service & Warranty Information	page 12

SPECIFICATIONS

Input Power Source	108 to 130VAC @ 60Hz
Power Supplies	<p>Fixed: +5V +/-0.2VDC, 1.0A max, current limited Load Regulation better than 0.8% +/- 0.02%/°C Ripple, <4mVp-p @1A</p> <p>Variable: Factory Set to +15VDC, with internal adjustment +5.5 to 18VDC, 0.5A max@ +15VDC Load Regulation better than 1% +/- 0.04%/°C, Ripple less that 10mVp-p @ 0.5A</p> <p>Variable: Factory Set to -15VDC, with internal adjustment -5.5 to -18VDC, 0.5A max@ +15VDC Load Regulation better than 1% +/- 0.04%/°C Ripple less that 10mVp-p @ 0.5A</p>
Binding Posts	(1) Black: Chassis Ground (3) Red: Power Supply Outputs +5VDC, +15VDC & -15VDC
Breadboards	2250 Tie points with (8) 100 pin and (2) 80 pin power rails and accommodates up to 24 (14 pin) IC's
Weight	5lb, 5oz
Dimensions	9.8" x 6.6" x 3.3"

OPERATING INSTRUCTIONS

Uncoil the power cord and plug the PB-203A into a 115V AC 60 Hz outlet. Push the power switch on. The power supply bank is now active, providing +5 Volts at 1 Amp for digital circuitry, and +15 and -15 Volt supplies at 0.5 Amp for linear and op-amp circuitry. All supplies are regulated and current limited for maximum performance and safety. The black binding post is common ground to all power supplies.

POWER DISTRIBUTION AND JUMPER WIRES

Ten distribution buses (solderless breadboard strips) are provided on each PB-203A. They include two horizontal buses with 40 contacts (80 total tie points) each and eight vertical buses with 50 contacts each (400 total tie points). One possible power distribution scheme for a single power supply is shown in Figure 1.

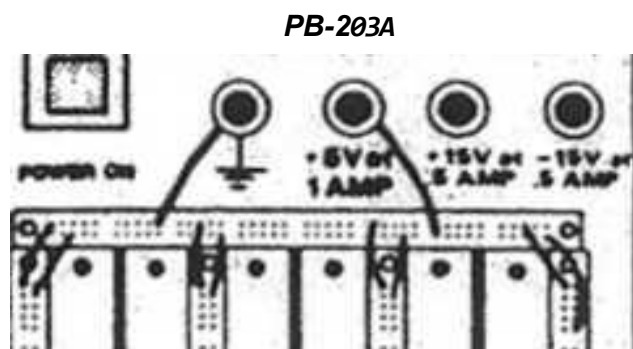

FIGURE 1. Power Distribution

The jumper wires should be #22 gauge solid hook-up wire. Global suggests that the insulation on the jumper wires be stripped 1/2" to 3/8" from each end to ensure easy insertion into the solderless breadboards. After you've built up a few circuits, you'll have a good collection of pre-stripped jumper wires. Pre-formed wires in various sizes are also available from Global Specialties (please visit web site for available options and accessories).

COMPONENT INSERTION

ICs are mounted by lining up the leads with the contact holes on each side of the center of the solderless breadboard, then pressing gently at the center of the IC until it clicks into position. Withdrawing the IC can be tricky. You should use a thin-bladed screwdriver, IC puller. Slide the end of the screwdriver blade under one end of the IC and lift gently. Repeat on the other side, then remove the IC from the socket. By following this procedure, you will not bend the delicate leads of the IC.

T0-5 case ICs can be inserted by pre-forming the leads with a set of long nose pliers, so the leads resemble a DIP pack.

Transistors can be inserted bridging the center of the breadboard or with leads-in-line on one side of the socket.

Diodes, resistors, and capacitors may be inserted in the same manner as jumper wires.

BROKEN WIRES

Sometimes a wire will break off at the surface of a breadboard contact hole. Two ways of solving this problem are as follows:

1. Push the broken wire into the socket. This will not affect the operation of the contact.

2.
 - a) Remove the 4 screws on the bottom of the case
 - b) Remove the 2 flathead screws located on the black top surface of the PB-203A.
 - c) The top and bottom case halves can now come apart.
 - d) Remove the screws holding the sockets to the top cover.
 - e) Unsnap the sockets. Remove the vinyl label from the socket containing the broken wire (a heat gun or hair dryer may be required to remove label).
 - f) Remove the terminal by inserting a round, stiff .025 pin into one of the unblocked holes. (A small paper clip, bent open, will also work.)
 - g) Force the terminal completely out of the socket.
 - h) Remove the broken wire, then replace the terminal. Be sure to press down firmly.
 - i) Replace the vinyl label, snap the sockets together, and remount them on the cover.

NOTE: DO NOT TIGHTEN SCREWS TOO MUCH OR YOU MAY STRIP THE THREADS IN THE PLASTIC BODY.

POWER SUPPLIES

Each power supply of the PB-203A is regulated using a 7805 Integrated Circuit. This circuit provides the plus and minus 15 Volt rail voltages, as well as the 5V supply available for use in breadboard experiments. Resistors R4 and R6 are the programming potentiometers, which are factory-set for 15V outputs. Figure 2 shows the circuit diagram of the PB-203A.

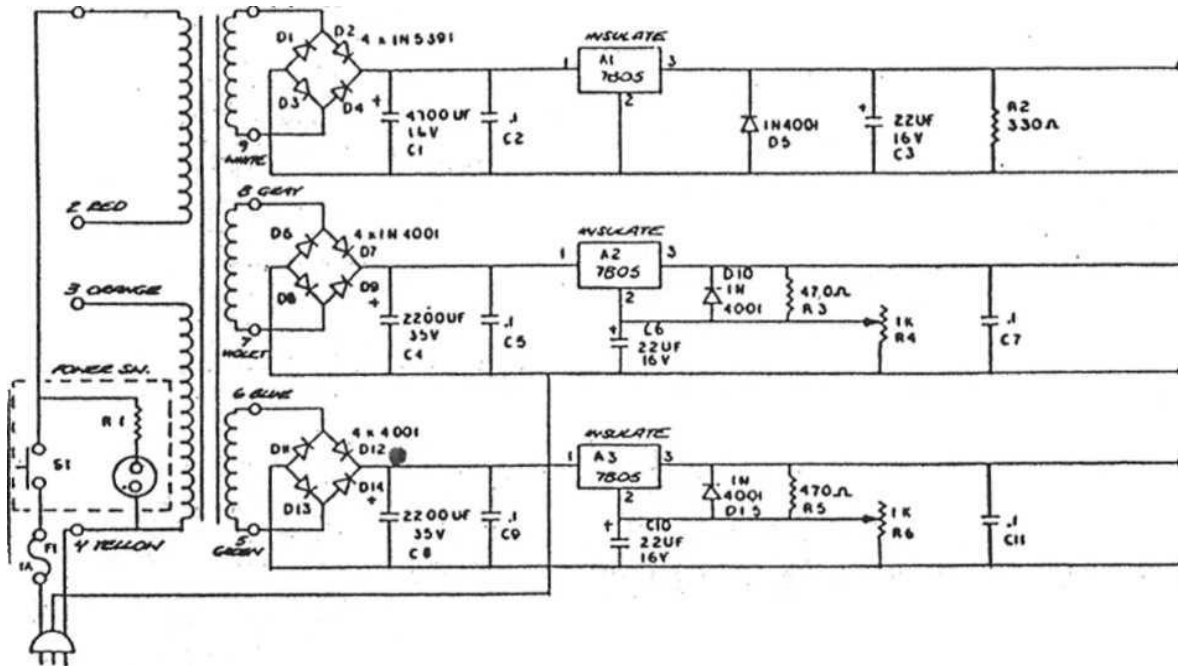

FIGURE 2. Schematic Diagram

USING THE PB-203A

The PB-203A is ideally suited for virtually any type of bread-boarding circuitry, from TTL, CMOS and ECL, to op-amps, audio, comparators, video amps, microprocessor components, phase locks and more. In order to get the most out of your breadboarding experience, the following guidelines and tips should be observed.

Ground Loops: A ground loop is a Voltage drop on a ground bus, caused by a power stage output ground, when entering the ground bus some distance away from the power supply ground binding post. Although this Voltage drop may only be in the millivolts or microvolts, it's part of the output load. If a preamplifier input or circuit ground is connected to a portion of this ground bus, feedback and oscillation can occur. This issue can be resolved by positioning all output stages closest to the ground terminal, with pre-amps further away.

By observing this simple rule, you will save hours of troubleshooting. Many audio ICs have separate input and output grounds to prevent ground loops.

By-Pass Capacitors: Even though the PB-203A's power supplies are tightly regulated, even a short length of power bus can cause a linear IC to break into oscillation at high frequencies due to increased inductance. This increased inductance can be offset by adding simple by-pass capacitors. By-pass capacitors (0.1pF ceramic disk type will be sufficient) should by-pass the power buses as close to the ICs power supply pins as possible. Utilize this technique for each IC.

Do not use electrolytic or paper capacitors as power bus by-pass capacitors. They have high inductances, and become unreliable as by-passes above 1MHz.

Good by-passing should also be used with digital ICs to prevent the inability to reset or clear, and false triggering.

COMBINING POWER SUPPLIES

The PB-203A can be configured in 2 additional voltage configurations beyond the 3 available fixed supply voltages. (See figure 3 below)

1. 30V Supply. By adding the 15 Volt supplies we can produce a 30 Volt supply at 0.25 Amps. This configuration requires that the load be placed across the +15 Volt terminal and the -15 Volt terminal.
2. 20V Supply. The +5 V supply can be added to the -15 V supply to make a 20 V supply. This configuration will require that the load be placed across the -15 Volt terminal and the +5 V terminal.

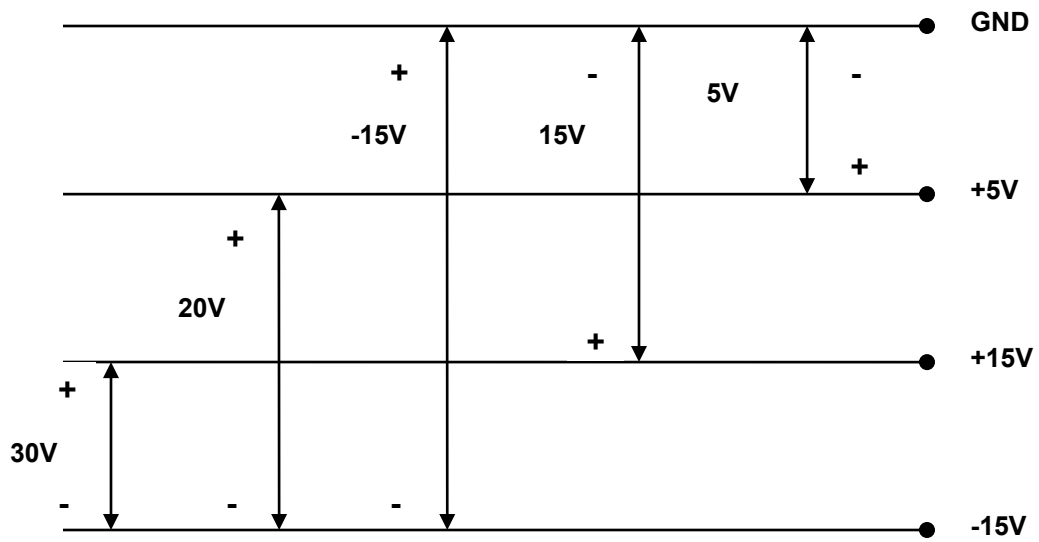

FIGURE 3. Power Supply Combinations

SERVICE AND WARRANTY INFORMATION

WARRANTY

Global Specialties warrants this device to be free from defective material or workmanship for a period of 3 full years from date of original purchase. Under this warranty, Global Specialties is limited to repairing the defective device when returned to the factory, shipping charges prepaid, within 3 full years from date of original purchase.

Units returned to Global Specialties that have been subject to abuse, misuse, damage or accident, or have been connected, installed or adjusted contrary to the instructions furnished by Global Specialties, or that have been repaired by unauthorized persons will not be covered by this warranty.

Global Specialties reserves the right to discontinue models, change specifications, price or design of this device at any time without notice and without incurring any obligation whatsoever.

The purchaser agrees to assume all liabilities for any damages and/or bodily injury which may result from the use or misuse of this device by the purchaser, his employees, or agents.

This warranty is in lieu of all other representations or warranties expressed or implied and no agent or representative of Global Specialties is authorized to assume any other obligation in connection with the sale and purchase of this device.

Specifications subject to change without notice.

Test Equipment Depot - 800.517.8431 - 99 Washington Street Melrose, MA 02176

TestEquipmentDepot.com