



1-800-517-8431

99 Washington Street
Melrose, MA 02176
Phone 781-665-1400
Toll Free 1-800-517-8431



Visit us at www.TestEquipmentDepot.com

DC Electronic Load Booster

PEL-3211(H)

USER MANUAL

VERSION: 1.15

ISO-9001 CERTIFIED MANUFACTURER

GW INSTEK

This manual contains proprietary information, which is protected by copyright. All rights are reserved. No part of this manual may be photocopied, reproduced or translated to another language without prior written consent of Good Will company.

The information in this manual was correct at the time of printing. However, Good Will continues to improve products and reserves the rights to change specification, equipment, and maintenance procedures at any time without notice.

Good Will Instrument Co., Ltd.
No. 7-1, Jhongsing Rd., Tucheng Dist., New Taipei City 236, Taiwan.

Table of Contents

SAFETY INSTRUCTIONS	2
GETTING STARTED	7
PEL-3211 (H) Booster Pack Introduction	8
Accessories	10
Appearance.....	13
First Time Use Instructions	16
OPERATION	27
Connection	28
Operation	33
MAINTENANCE	35
Replacing the Dust Filter	35
APPENDIX	36
Frame Control Connector Contacts	36
Operating Area	38
PEL-3211 (H) Booster Pack	
Specifications	40
Dimensions	41
Declaration of Conformity.....	42
INDEX	44

S SAFETY INSTRUCTIONS

This chapter contains important safety instructions that you must follow during operation and storage. Read the following before any operation to insure your safety and to keep the instrument in the best possible condition.

Safety Symbols

These safety symbols may appear in this manual or on the instrument.



Warning: Identifies conditions or practices that could result in injury or loss of life.



Caution: Identifies conditions or practices that could result in damage to the instrument or to other properties.



DANGER High Voltage



Attention Refer to the Manual



Earth (ground) Terminal



Frame or Chassis Terminal



Do not dispose electronic equipment as unsorted municipal waste. Please use a separate collection facility or contact the supplier from which this instrument was purchased.

Safety Guidelines

General Guideline



CAUTION

- Do not place any heavy object on the instrument. Note: Only two booster units can be stacked vertically.
- Avoid severe impact or rough handling that leads to damaging the instrument.
- Do not discharge static electricity to the instrument.
- Use only crimped wires, not bare wires, for the terminals.
- Do not block the cooling fan opening.
- Do not disassemble the instrument unless you are qualified.
- The equipment is not for measurements performed for CAT II, III and IV.

(Measurement categories) EN 61010-1:2010 specifies the measurement categories and their requirements as follows. The instrument falls under category II.

- Measurement category IV is for measurement performed at the source of low-voltage installation.
 - Measurement category III is for measurement performed in the building installation.
 - Measurement category II is for measurement performed on the circuits directly connected to the low voltage installation.
 - 0 is for measurements performed on circuits not directly connected to Mains.
-

Power Supply**WARNING**

- AC Input voltage range: 100-120VAC/200-240VAC
(90-132VAC/180-250VAC)
 - Frequency: 47-63Hz
 - Power:
PEL-3211(H): 230VA Max
 - To avoid electrical shock connect the protective grounding conductor of the AC power cord to an earth ground.
-

Cleaning

- Disconnect the power cord before cleaning.
 - Use a soft cloth dampened in a solution of mild detergent and water. Do not spray any liquid.
 - Do not use chemicals containing harsh material such as benzene, toluene, xylene, and acetone.
-

Operation Environment

- Location: Indoor, no direct sunlight, dust free, almost non-conductive pollution (Note below)
- Temperature: 0°C to 40°C
- Humidity: 0 to 85% RH
- Altitude: <2000m

(Pollution Degree) EN 61010-1:2010 specifies the pollution degrees and their requirements as follows. The instrument falls under degree 2.

Pollution refers to “addition of foreign matter, solid, liquid, or gaseous (ionized gases), that may produce a reduction of dielectric strength or surface resistivity”.

- Pollution degree 1: No pollution or only dry, non-conductive pollution occurs. The pollution has no influence.
- Pollution degree 2: Normally only non-conductive pollution occurs. Occasionally, however, a temporary conductivity caused by condensation must be expected.
- Pollution degree 3: Conductive pollution occurs, or dry, non-conductive pollution occurs which becomes conductive due to condensation which is expected. In such conditions, equipment is normally protected against exposure to direct sunlight, precipitation, and full wind pressure, but neither temperature nor humidity is controlled.

Storage environment

- Location: Indoor
- Temperature: -20°C to 70°C
- Humidity: <90% RH

Disposal



Do not dispose this instrument as unsorted municipal waste. Please use a separate collection facility or contact the supplier from which this instrument was purchased. Please make sure discarded electrical waste is properly recycled to reduce environmental impact.

Power cord for the United Kingdom

When using the instrument in the United Kingdom, make sure the power cord meets the following safety instructions.

NOTE: This lead/appliance must only be wired by competent persons



WARNING: THIS APPLIANCE MUST BE EARTHED

IMPORTANT: The wires in this lead are coloured in accordance with the following code:

Green/ Yellow:	Earth
Blue:	Neutral
Brown:	Live (Phase)



As the colours of the wires in main leads may not correspond with the coloured marking identified in your plug/appliance, proceed as follows:

The wire which is coloured Green & Yellow must be connected to the Earth terminal marked with either the letter E, the earth symbol \oplus or coloured Green/Green & Yellow.

The wire which is coloured Blue must be connected to the terminal which is marked with the letter N or coloured Blue or Black.

The wire which is coloured Brown must be connected to the terminal marked with the letter L or P or coloured Brown or Red.

If in doubt, consult the instructions provided with the equipment or contact the supplier.

This cable/appliance should be protected by a suitably rated and approved HBC mains fuse: refer to the rating information on the equipment and/or user instructions for details. As a guide, a cable of 0.75mm² should be protected by a 3A or 5A fuse. Larger conductors would normally require 13A types, depending on the connection method used.

Any exposed wiring from a cable, plug or connection that is engaged in a live socket is extremely hazardous. If a cable or plug is deemed hazardous, turn off the mains power and remove the cable, any fuses and fuse assemblies. All hazardous wiring must be immediately destroyed and replaced in accordance to the above standard.

G E T T I N G S T A R T E D

This chapter provides a brief overview of the PEL-3211, the package contents, instructions for first time use and an introduction to the front panel and rear panel.



PEL-3211 (H) Booster Pack Introduction	8
Booster Capacity	8
Main Features	9
Accessories	10
Package Contents	12
Appearance	13
Front Panel	13
Rear Panel	14
First Time Use Instructions	16
Rack Mount Kits	16
Power Up	18
Load Wiring	18
Using the Rear Panel Input Terminals	21
Using the Terminal Cover (PEL-011)	22
Using the Terminal Cover (PEL-013)	25

PEL-3211 (H) Booster Pack Introduction

The PEL-3211(H) Booster is designed to be used with the PEL-3111(H) Electronic Load for parallel load applications to increase the current sinking capacity. Up to 4 booster packs can be connected as slave units to a PEL-3111(H), which acts as the master unit.

Please note that throughout this manual the term “PEL-3000(H)” refers to any one of the models in the series lineup, unless specifically stated otherwise. The term “booster” refers only to the PEL-3211(H). The term “master” or “master unit” refers to the PEL-3111(H) unit that is configured as the master unit when in parallel mode.

Booster Capacity

The table below shows the total current and power capacity by the number of booster packs connected to a PEL-3111(H) master unit.

No. of Boosters	Total Current: Boosters+Master (PEL-3211(H)+PEL-3111(H))	Total Power: Boosters+Master (PEL-3211(H)+PEL-3111(H))
1	630A (420A+210A) (H)157.5A(105A+52.5A)	3150W (2100W+1050W)
2	1050A (840A+210A) (H)262.5A(210A+52.5A)	5250W (4200W+1050W)
3	1470A (1260A+210A) (H)367.5A(315A+52.5A)	7350W (6300W+1050W)
4	1890A (1680A+210A) (H)472.5A(420A+52.5A)	9450W (8400W+1050W)

Main Features

Features

- Up to 4 booster packs can be used in parallel with a PEL-3111(H) master unit.
 - All booster packs are controlled via a master unit.
-

Accessories

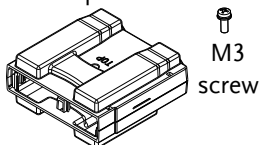
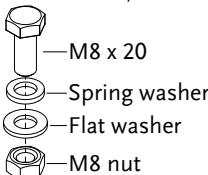
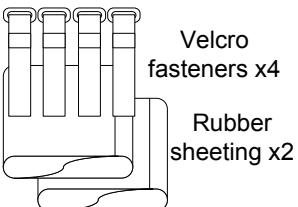
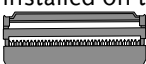
Standard Accessories	Part number	Description
		Booster Quick Start Guide
	Region dependant	Power cord
	PEL-011	Load input terminal Cover
		 <p>M3 screw</p>
	PEL-012	Terminal fittings: 2 sets of bolts/nuts/springs/washers (type: M8), Terminal Cover x1 (only for PEL-3000H series), Monitor Out Cover x 1 (only for PEL-3021H, PEL-3041H, PEL-3111H)
		 <p>M8 x 20 Spring washer Flat washer M8 nut</p>
	PEL-013	Flexible terminal cover: 2x rubber sheeting, 4x Velcro fasteners. (For PEL-3211(H) only)
		 <p>Velcro fasteners x4 Rubber sheeting x2</p>
	PEL-014	J1/J2 Protection plug x2 (It is installed on the device)
		

GTL-255	300mm Frame Link Cable (for linking units that are stacked)
---------	---

Optional Accessories	Part number	Description
	GRA-413	Rack mount bracket for booster PEL-3211(H) (EIA + JIS)
	PEL-010	Dust Filter

Package Contents

Check the contents before using the instrument.

Opening the box

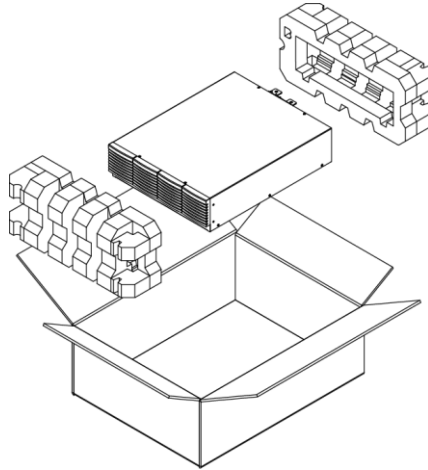

Contents (single unit)

- Main unit
- Booster Quick Start manual
- Terminal fittings
- Power cord x1 (region dependent)
- Calibration certificate
- Frame link cable

Appearance

Front Panel

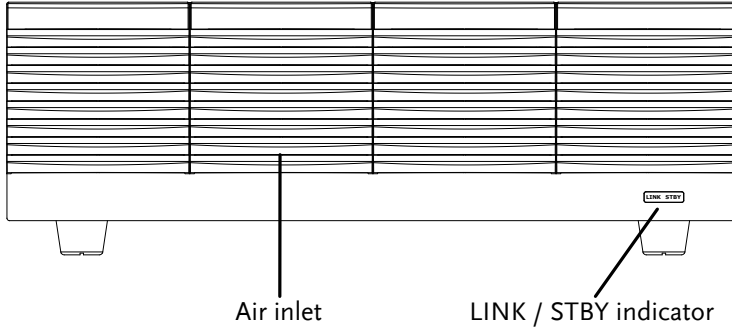

LINK/STBY Indicator

The LINK and STBY indicators indicate when the booster pack is properly connected and when the power has been turned on, respectively.

Power on:



Load on and connected:



Air Inlet

Air Inlet. Contains a dust filter. See the maintenance chapter for details.

Rear Panel

Frame control ports,
J1, J2

Remote sense
inputs

Rear panel
inputs

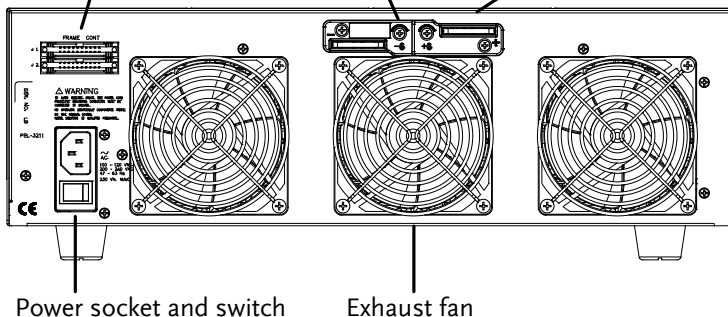

Frame control
ports, J1, J2

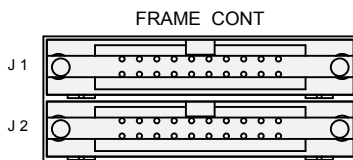

J1: The J1 connector is used for parallel operation. This connector links to the master unit or to the previous slave unit.

J2: The J2 connector is used for parallel operation control. This unit links to the next slave unit.

Exhaust fan

The exhaust fan is used to expel the heat from the unit. Please ensure there is at least 20cm distance between any object and the fan.

Rear Panel Input
terminals

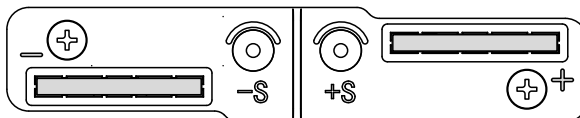

Rear Panel Input Terminals. Electrically connected to the front panel input terminals. Accepts M8 bolts or M4/M3 sized screws. See page 21 for connection details.

Remote Sensing Terminals

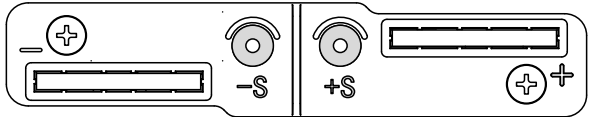

Sensing terminals for remote sense. See page 22.

Accepts M3 sized banana plugs.

Power Socket

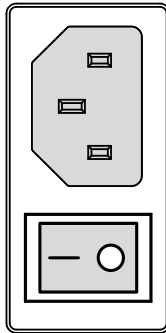

Power Socket:
100-120V, 200-240V
47-63Hz.

Power Switch

Turns the unit on/off.

First Time Use Instructions

Use the procedures below when first using the PEL-3211(H) booster pack to install the rack mount kit and power up the instrument.

Rack Mount Kits

Description The GRA-413 rack mounts are suitable for the PEL-3211(H) booster pack. The GRA-413 rack mounts come in IEA or JIS variants.

For installation details, please see the GRA-413 Rack Mount Assembly Manual.

Please see your distributor for which rack mount is suitable for your application.

GRA-413
(EIA standard)

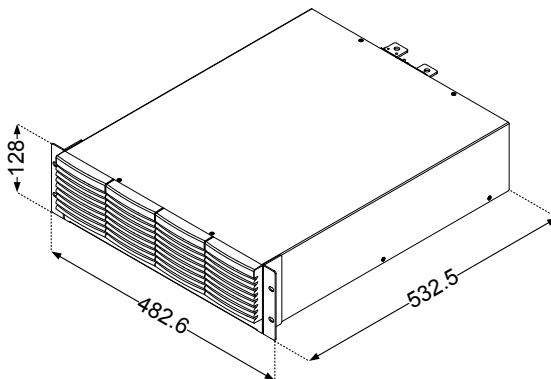
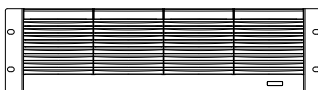

GRA-413
(JIS standard)

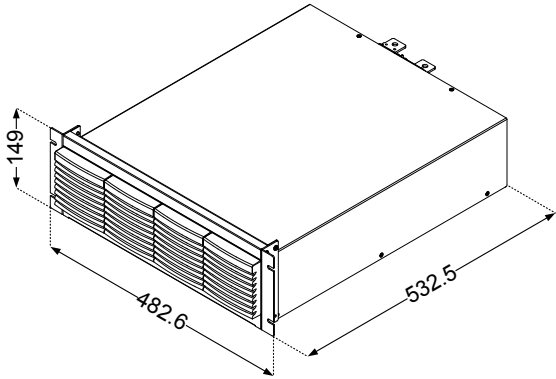

Power Up

Steps

1. Insert the AC power cord into the power socket.

2. Turn the external power switch on.
(O → -)

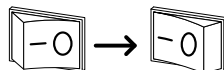

3. When the power is turned on the LINK/STBY indicator will light up.

- STBY indicator on the front panel will become red when the power is on.



Note

If the LINK/STBY indicator fails to light up, please see your local distributor.

Load Wiring

Wire Gauge considerations

Before connecting the booster packs to a DUT, the wire gauge must be taken into account. Load wires must be large enough to resist overheating when a short-circuit condition occurs as well as maintain a good regulation. The size, polarity and length of a wire are all factors in determining if a wire will withstand short circuiting.

Wires that are selected must be large enough to withstand a short circuit and limit voltage drops to no more than 2V per wire. Use the table below to help make a suitable selection.

AWG Gauge	Conduct or Diameter mm	Ohms per km	Max amps for chassis wiring
0000	11.684	0.16072	380
000	10.4038	0.2027	328
00	9.26592	0.25551	283
0	8.25246	0.32242	245
1	7.34822	0.40639	211
2	6.54304	0.51266	181
3	5.82676	0.64616	158
4	5.18922	0.81508	135
5	4.62026	1.02762	118
6	4.1148	1.29593	101
7	3.66522	1.6341	89
8	3.2639	2.0605	73
9	2.90576	2.59809	64
10	2.58826	3.27639	55
11	2.30378	4.1328	47
12	2.05232	5.20864	41
13	1.8288	6.56984	35
14	1.62814	8.282	32

Load Line Inductance Considerations

When using the booster packs, voltage drop and voltage generated due to load line inductance and current change must be taken into account. Extreme changes in voltage may exceed the minimum or maximum voltage limits. Exceeding the maximum voltage limit may damage the booster(s).

To determine the voltage generated, the following equation can be used.

$$E = L \times (\Delta I / \Delta T)$$

E= voltage generated

L=load line inductance

Δ I= change of current (A)

Δ T= time (us)

Load line inductance (L) can be approximated as 1uH per 1 meter of wire. ($\Delta I / \Delta T$) is the slew rate in A/us.

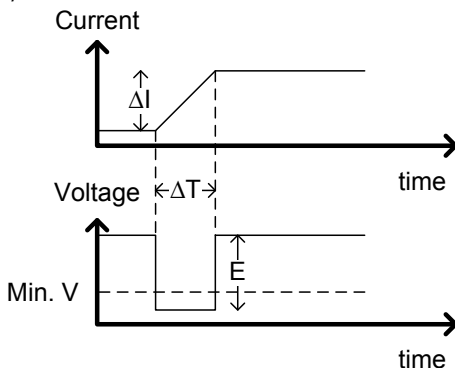

The diagram above shows how changes in current can affect voltage.

Limiting Load line inductance Load line inductance can be reduced in two ways.

1. Ensure load wires are as short as possible and twist the positive and negative load wires together.
2. Current change can be limited by limiting the slew rate or response speed when switching in CR and CC mode.

Using the Rear Panel Input Terminals

Description The rear panel input terminals accept up to M8-sized crimped terminals. The rear terminals come with a load input terminal cover for safety.

- Steps**
1. Turn the power off from the rear panel.
 2. Turn the power off from the DUT.
 3. Connect the load wires to the input terminals:
 - Connect the positive (+) input terminal on the load generator to the high potential output of the DUT.
 - Connect the negative (-) input terminal to the low potential output of the DUT.

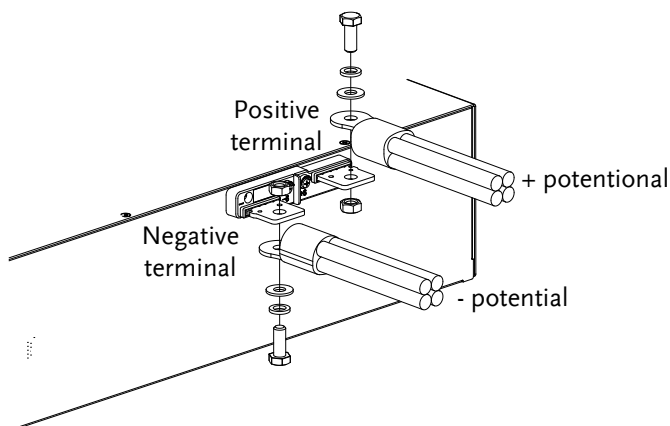

Using the Terminal Cover (PEL-011)

Description The rear panel terminal cover should be used to prevent electric shock. The rear panel terminal covers should always be used when connecting a load to the rear panel terminals.

 **Caution** Ensure the power is off before making any connections to the booster pack.

 **Note** The PEL-013 (flexible terminal cover, see page 25) can be used if the thickness of the load wiring becomes too unwieldy for use with the PEL-012 terminal cover.

 **Note** In the following diagrams, the cable wiring is not shown for clarity.

1. Remove the screw holding the top cover to the bottom cover.

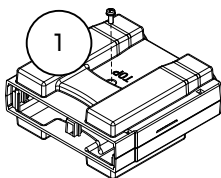

2. Line-up the bottom cover with the notches in the output terminals.
3. Place the top terminal cover over the bottom cover.

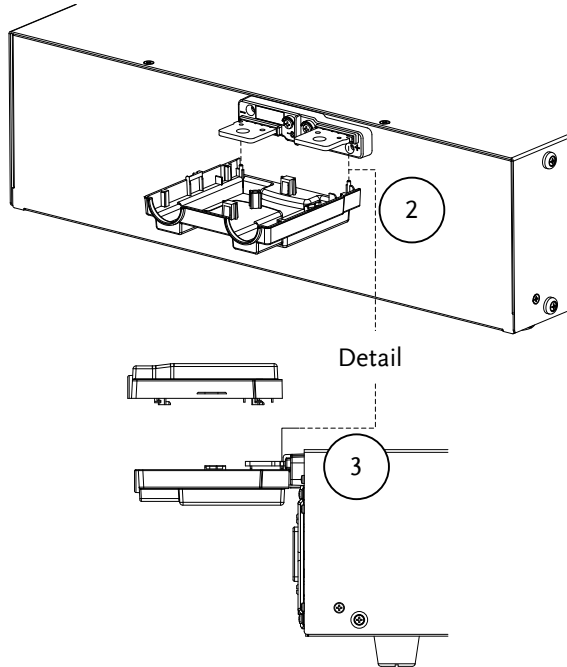

4. Use your thumb to slide the terminal covers shut, as shown in the diagram below.

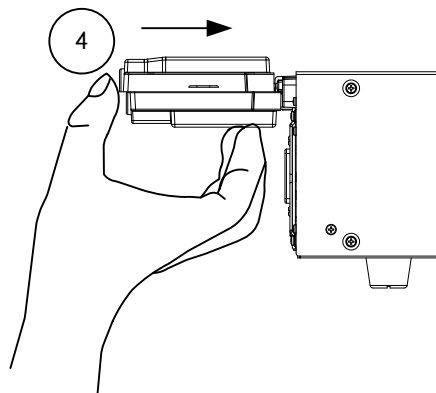

5. When the top and bottom covers are flush, reinsert the screw that was removed in step 1.

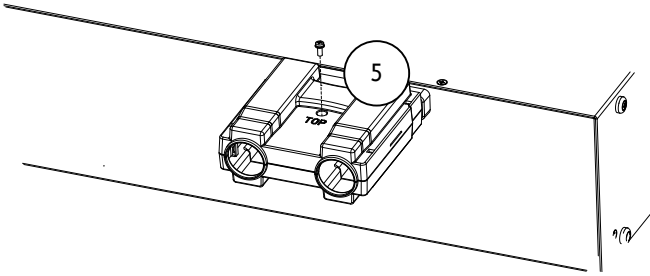

Using the Terminal Cover (PEL-013)

Description The flexible rear panel terminal cover should be used when the load wiring becomes too thick to be used with the PEL-012 terminal cover. This is especially true when using the load generators in parallel. Like the PEL-013 terminal cover, the PEL-012 is used to prevent electric shock. The rear panel terminal covers should always be used when connecting a load to the rear panel terminals.

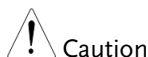

Caution

Ensure the power is off before making any connections to the booster pack.

1. Wrap the insulation sheets around the terminals and load cables, as shown below. Make sure the terminals and any exposed wires are covered by the sheets.

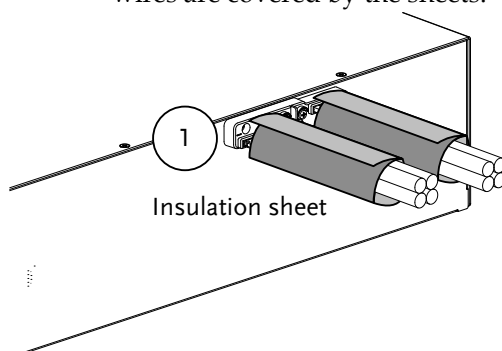

2. Secure the insulation sheets using the supplied velcro fasteners. 2 fasteners should be used for each sheet.

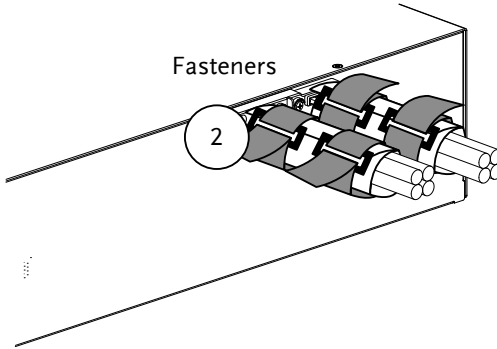

OPERATION

Connection	28
Frame Link Connections.....	28
Load Wire Connections	29
Operation	33
Configuration	33
Turning the Load On.....	34

Connection

The PEL-3111(H) can control up to 4 PEL-3211(H) booster units in parallel. Excluding the master unit, other PEL-3000(H) units cannot be used in parallel with the booster packs.

Master unit settings for response rate, response speed and so on will be adopted by any connected booster packs.

Frame Link Connections

Description	The J1 and J2 connectors on the rear panel are used to control the booster packs for parallel operation. The GTL-255 cable is used to connect the J1 and J2 connectors. The GTL-255 frame link cable is used for units that are stacked vertically.
-------------	---



Note

Ensure that the frame link cables are separated as much as possible from the load cables to prevent unstable operation.

Connection	<ol style="list-style-type: none"> 1. Make sure the master unit and booster packs are turned off. 2. Make sure the DUT is turned off. 3. Connect the Master unit to the booster packs via the J1/J2 connectors*. <ul style="list-style-type: none"> • Use the GTL-255 frame link cables. • Connect from: Master J2 → Slave1 J1 Slave1 J2 → Slave2 J1 and so on. • Remove one ferrite core from the last frame link cable. Remove the ferrite core that is closest to the J1 port on the last slave unit. See the diagram below for details.
------------	--

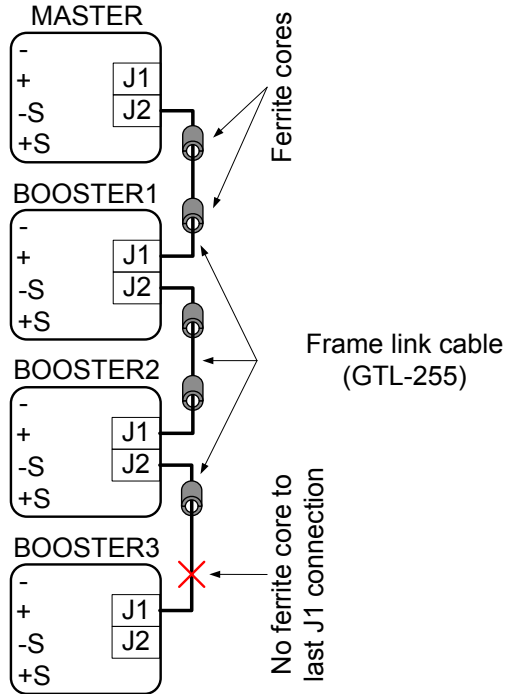

 Caution

*Failing to remove the last ferrite core from the GTL-255 cable may reduce the stability of the units when used in parallel.

Load Wire Connections

 Note

Follow the procedures below for all load connections. Please adhere to the following precautions to ensure your safety and to protect the unit from damage.

 Caution

If the polarity to the input terminals is reversed, the reverse voltage protection function is tripped. The reverse voltage protection function is tripped when reverse voltages greater than -0.3V are detected.



Caution

Ensure that the maximum input voltage is not exceeded. The maximum input voltage is 150(800) volts.



Warning

Do not touch any of the input terminals when the unit is on.



Warning

Connecting the input terminals to the wrong polarity can damage the DUT or the booster packs/master unit.

Load Connection

1. Make sure the master unit and booster packs are turned off.
2. Make sure the DUT is turned off.
3. Connect the load units to the DUT.
 - Ensure the wire gauge is sufficient to handle the increase in current.
 - Connect the *rear* negative terminals on the booster(s) and master unit to the negative potential of the DUT.
 - Connect the *rear* positive terminals on the booster(s) and master unit to the positive potential on the DUT.
 - If possible use the shortest cable length possible.
 - If possible, twist the load cables together to reduce load line inductance.
 - Try to use cables of equal length.
 - Do not coil or loop the load cables.

- Sense Connection
1. Remote sense can be used to help compensate for long cable length. The longer the cable, the higher the potential resistance and inductance, therefore a short cable is best. Twisting the cable can help reduce induced inductance and using the Vsense terminals compensates the voltage drop seen across the load leads, especially leads with higher resistance. This is useful when used in CV, CR or CP mode. Make sure the master unit and booster packs are turned off.
 1. Make sure the DUT is turned off.
 2. Connect the sense cables from the DUT to the master unit
 - Connect a sense cable from the positive sense terminal to the positive potential of the DUT.
 - Connect a sense cable from the negative sense terminal to negative potential on the DUT.
 - Do not connect the sense cables to the booster packs.

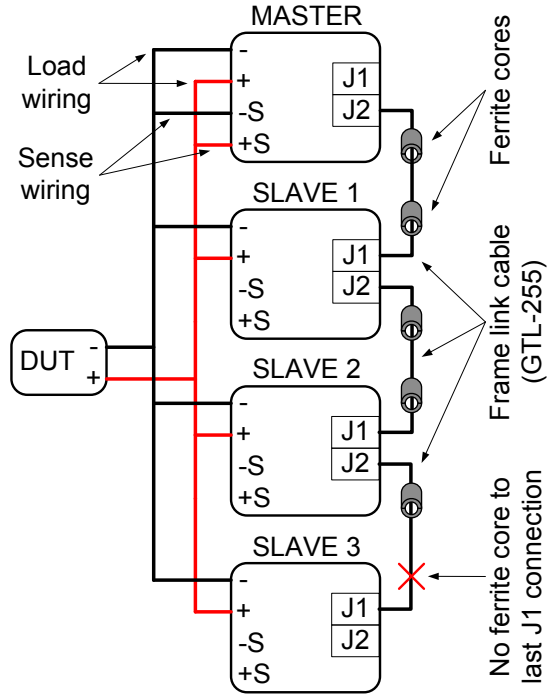

! Cautions

Only the rear terminals on the master can be used for parallel connections.

Make sure all connections are correct before turning on the load. Incorrect connections could damage the units.

The booster packs should not be used with a combination of other PEL-3000(H) units as slaves other than the PEL-3111(H) acting as the master.

Ensure that wiring of sufficient gauge is used when using parallel connections.

If using voltage sense, only connect the master to the voltage sense terminals.

Operation

Configuration

Description When using multiple units in parallel all the basic settings are adopted from the master unit.

- Operation**
1. Ensure the master unit, booster packs and DUT are connected in parallel.
 2. Turn the booster packs and master unit on.
 3. On the master unit, press **Main** > *Configure* [F5] > *Next Menu* [F4] > *Parallel*[F1].
 4. Set the unit to *Master* with the *Operation* setting.
 5. Assign the number of attached booster units with the *Booster* settings.
 - A maximum of 4 booster units can be used in parallel.



6. The electronic loads are now ready for operation.

Turning the Load On



Note

When operating in parallel, the load line inductance could be increased or the stability of the units could be reduced. If necessary, reduce the response speed setting and slew rate setting to increase stability. See the user manual for details.

1. Turn the slave and master units on.
2. Set the operation mode and settings on the master unit.
 - The master's settings will be used by the slave units.
3. Turn the load on from the Master unit.
 - All measurements will be displayed updated on the Master unit only.
4. The LINK indicator will turn green when the load is on and the booster units are connected.

M AINTENANCE

Replacing the Dust Filter

Background The dust filter should be replaced twice a year. Not replacing the filter will reduce performance and may cause the PEL-3211(H) to malfunction.

- Procedure**
1. Turn the PEL-3211(H) off at the rear panel power switch.

Gently lift the grill up from the bottom.

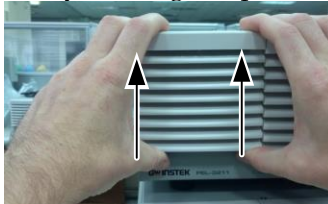

2. Remove the filter from the grill and replace with GW Instek part number:PEL-010.

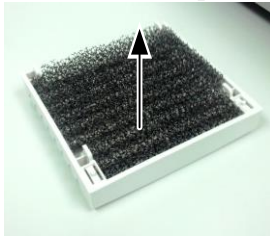

APPENDIX

Frame Control Connector Contacts

J1 Connector Booster

Pin name	Pin number	Description
N.C.	1	Not connected.
N.C.	2	Not connected.
A COM	3	Connected to the negative load input terminal.
SUM I MON	4	Connected to SUM I MON of the J2 connector.
PRL IN+	5	Connected to PRL OUT+ of the J2 connector.
PRL IN-	6	Connected to PRL OUT- of the J2 connector.
LOAD ON/OFF CONT	7	Turns on the load with low (or high) TTL level signal.
N.C.	8	Pulled up by the internal circuit to 5 V using 10 k Ω .
RANGE CONT 0	9	External range switch input*1 *2 Pulled up the internal circuit to 5 V using 10 k Ω .
ALARM INPUT	10	Activates an alarm with high (or low) TTL level signal input. Pulled up by the internal circuit to 5 V.
N.C.	11	Not connected.
A COM	12	Connected to the negative load input terminal on the rear panel.
N.C.	13	Not connected.
N.C.	14	Not connected.
N.C.	15	Not connected.
ALARM STATUS	16	Turns on when an alarm (OVP, OCP, OPP, OHP, REV, or UVP) is activated or when an external alarm is applied. Open collector output by a photocoupler.*3
STATUS COM	17	STATUS signal common for pins 16.
N.C.	18	Not connected.

A COM	19	Connected to the negative load input terminal on the rear panel.
+15V	20	Controls the on/off of the load booster power (cannot be used for multiple purposes).

*1 Valid only when the front panel settings are H range.

*2	RANGE CONT 0	
	H range	1
	M range	1

*3 The maximum applied voltage of the photocoupler is 30 V; the maximum current is 8 mA.

J2 Connector Booster

Pin name	Pin number	Description
N.C.	1	Not connected.
N.C.	2	Not connected.
N.C.	3	Not connected.
SUM I MON	4	Connect to SUM I MON of the J1 connector.
PRL OUT+	5	Used during master/slave operation. Connected to PRL IN+ of the J1 connector.
PRL OUT-	6	Used during master/slave operation. Connected to PRL IN- of the J1 connector.
LOAD ON/OFF CONT	7	
N.C.	8	Not connected.
SLAVE RANGE CONT	9	Used during master/slave operation. Connected to RANGE CONT 0 of the J1 connector.
N.C.	10	Not connected.
N.C.	11	Not connected.
A COM	12	Connected to the negative load input terminal on the rear panel.
N.C.	13	Not connected.
N.C.	14	Not connected.
N.C.	15	Not connected.

ALARM INPUT	16	Activates an alarm with high (or low) TTL level signal input. Pulled up the internal circuit to 5 V.
A COM	17	Connected to the negative load input terminal.
N.C.	18	Not connected.
A COM	19	Connected to the negative load input terminal.
+15V	20	Controls the on/off of the load booster power (cannot be used for multiple purposes).

Operating Area

PEL-3211 Booster Pack

PEL-3211 High Range Chart

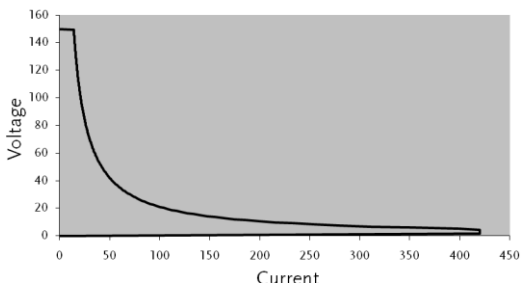

PEL-3211H Booster Pack

High Range Chart

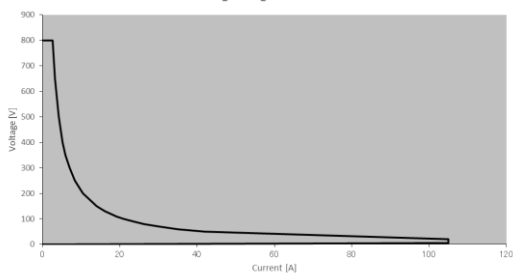

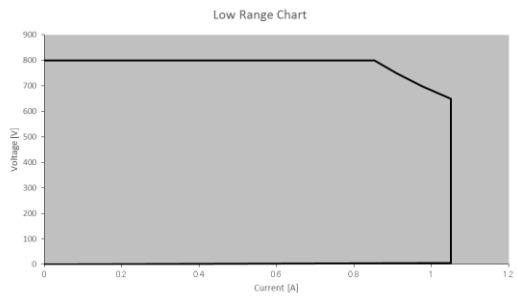
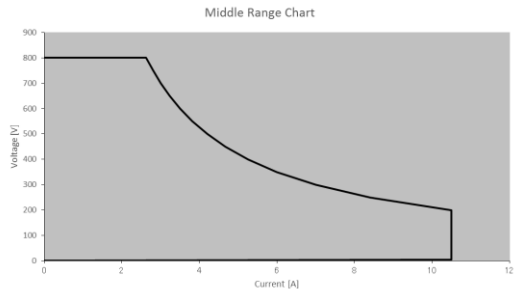

PEL-3211 (H) Booster Pack Specifications

The specifications apply when the PEL-3211(H) is powered on for at least 30 minutes to warm-up to a temperature of 20°C to 30°C, unless specified otherwise.

Rating

Model	PEL-3211 (H)
Voltage	0V-150V (0V-800V)
Current	420A (105A)
Min. Operating Voltage	1.5V at 420A (5V at 105A)
Power	2100W
Current Setting Accuracy	±(1.2% of set + 1.1% of f.s.) M range applies to the full scale of H range
 Note	PEL-3211 only have H or M current ranges.

General

Model	PEL-3211 (H)
Inrush Current	45A Max
Insulation Resistance	Primary to input terminal: 500(1000) VDC, 20MΩ or more. Primary to chassis: 500(1000) VDC, 20MΩ or more.
Withstand Voltage	Primary to input terminal: No abnormalities at 1500 VAC for 1 minute. Primary to chassis: No abnormalities at 1500 VAC for 1 minute.
Dimensions(mm)	427.7(W)x127.8(H)x553.5(D)
Weight	Approx. 23 (28)kg

Dimensions

PEL-3211(H)

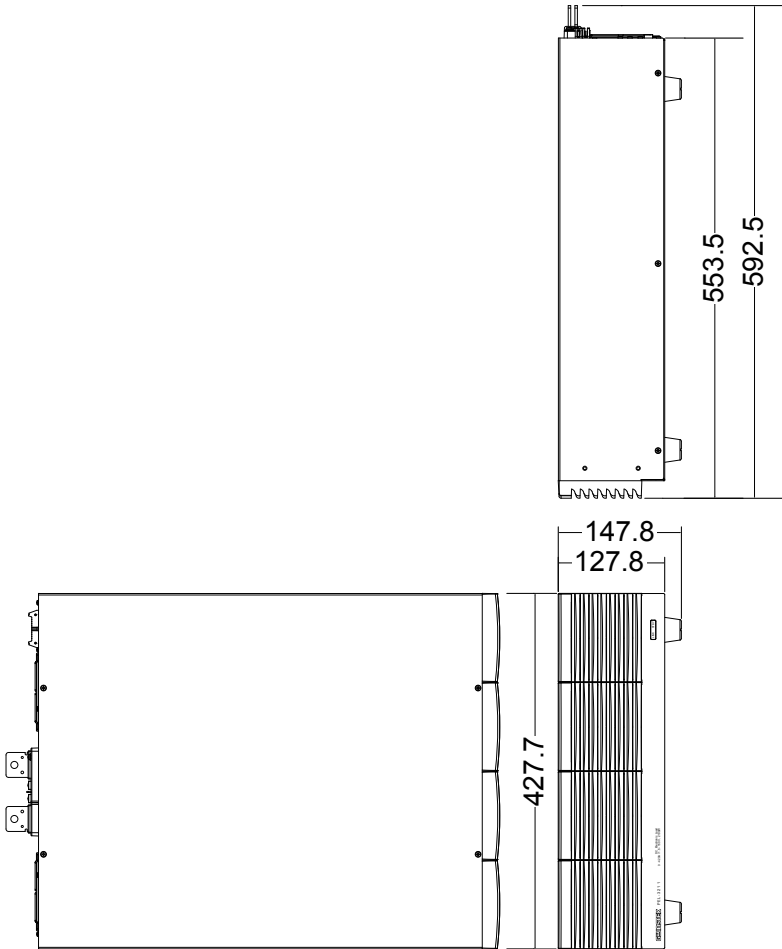

Declaration of Conformity

We

GOOD WILL INSTRUMENT CO., LTD.

declare that the below mentioned product

Type of Product: **Programmable Electronic Load**

PEL-3211

satisfies all the technical relations application to the product within the scope of council:

Directive: 2014/30/EU; 2014/35/EU; 2011/65/EU; 2012/19/EU

The above product is in conformity with the following standards or other normative documents:

◎ **EMC**

EN 61326-1 EN 61326-2-1	Electrical equipment for measurement, control and laboratory use -- EMC requirements (2013)	
Conducted & Radiated Emission EN55011: 2009+A1: 2010	Electrical Fast Transients EN 61000-4-4: 2012	
Current Harmonics EN 61000-3-2: 2014	Surge Immunity EN 61000-4-5: 2006	
Voltage Fluctuations EN 61000-3-3: 2013	Conducted Susceptibility EN 61000-4-6: 2014	
Electrostatic Discharge EN 61000-4-2: 2009	Power Frequency Magnetic Field EN 61000-4-8: 2010	
Radiated Immunity EN 61000-4-3: 2006 +A1:2008+A2:2010	Voltage Dip/ Interruption EN 61000-4-11: 2004	

◎ **Safety**

Low Voltage Equipment Directive 2014/35/EU	
Safety Requirements	EN 61010-1: 2010 EN 61010-2-030: 2010

We

GOOD WILL INSTRUMENT CO., LTD.

declare that the below mentioned product

Type of Product: **Programmable Electronic Load**

PEL-3211H

satisfies all the technical relations application to the product within the scope of council:

Directive: 2014/30/EU; 2014/35/EU; 2011/65/EU; 2012/19/EU

The above product is in conformity with the following standards or other normative documents:

◎ **EMC**

EN 61326-1 EN 61326-2-1	Electrical equipment for measurement, control and laboratory use -- EMC requirements (2013)	
Conducted & Radiated Emission EN55011: 2009+A1: 2017 Class A	Electrical Fast Transients IEC 61000-4-4: 2012	
Current Harmonics EN 61000-3-2: 2014	Surge Immunity IEC 61000-4-5: 2014+AMD1: 2017	
Voltage Fluctuations EN 61000-3-3: 2013	Conducted Susceptibility IEC 61000-4-6: 2013 COR1: 2015	
Electrostatic Discharge IEC 61000-4-2: 2008	Power Frequency Magnetic Field IEC 61000-4-8: 2009	
Radiated Immunity IEC 61000-4-3: 2006 +AMD2: 2010	Voltage Dip/ Interruption IEC 61000-4-11: 2004+AMD1: 2017	

◎ **Safety**

Low Voltage Equipment Directive 2014/35/EU	
Safety Requirements	EN 61010-1: 2010

INDEX

Accessories	10	PEL-3211	38
Caution symbol	2	PEL-3211H.....	38
Cleaning the instrument.....	4	Package contents.....	12
Declaration of conformity ..	42, 43	Parallel operation	
Disposal instructions.....	5	Configuration	33
Disposal symbol	2	Connection.....	28
EN61010		Overview	28
Measurement category	3	Power supply	
Pollution degree	5	Safety instruction	4
Environment		Power up.....	18
Safety instruction	4	Rack mount installation.....	16
FAQ.....	35	Rear panel diagram	14
First time use instructions	16	Replace the dust filter	35
Front panel diagram	13	Service operation	
Ground		About disassembly	3
Symbol.....	2	Specifications	
Input terminals		Dimensions.....	41
Rear.....	21	PEL-3211(H)	40
Terminal cover.....	22, 25	UK power cord.....	6
Load wiring.....	20	Warning symbol	2
Connection.....	28, 29	Wire gauge.....	18
Operating area		Theory	19