



RecoverXL™ and RecoverXLT™ Oil-Less Universal Refrigerant Recovery Systems



Operation and Maintenance Manual

Table of Contents

	Page
General Safety Instructions	2-3
<i>RecoverXL</i> Operation Guide	3-4
Direct Liquid/Vapor Recovery	
<i>RecoverXLT</i> Operating Guide	4-5
Direct Liquid/Vapor Recovery	
Restart Procedure	5
Push-Pull Liquid Recovery	5
Recovering R-410A High Pressure Gas	6
Care and Maintenance - Auto Purge Instructions	7
Recovery Tips & Techniques	7
Component Location and List	8-9
Troubleshooting Guide	9
Technical Data	10
Suction Filter	10
<i>RecoverXL/XLT</i> Wiring Diagrams	11
Important Notice to Purchaser	12
Warranty Information	12

General Safety Instructions

- 1) **Know your equipment.** Read and understand the operation manual and the labels affixed to this unit. Learn the applications and limitations, as well as the specific potential hazards of the *RecoverXL/XLT*.
- 2) **Use the correct hoses.** Use only hoses designed for handling of refrigerants. The hose should be the minimum length required for each job and equipped with a shut-off device (such as the compact ball valve) at the end to reduce the likelihood of refrigerant leaks to the atmosphere. For best performance we recommend using 3/8" hoses. *YELLOW JACKET hoses are made for almost every type of refrigerant. See your local distributor for more information.*
- 3) **Ground all equipment.** Plug the *RecoverXL/XLT* into a properly grounded receptacle using the appropriate plug.
- 4) **If the detachable power cord is damaged,** it must be replaced by a cord assembly available from the manufacturer or distributor where purchased.
- 5) **If the attached power socket is damaged,** it must be replaced by the manufacturer or its authorized service center in order to avoid hazard.
- 6) **Do not pressure test with compressed air.** Some mixtures of air and refrigerant have been shown to be combustible at elevated pressures.
- 7) **Avoid dangerous environments.** To keep operator exposure to a minimum, use the *RecoverXL/XLT* only in areas with sufficient ventilation.

Recovery should always be performed in well ventilated areas. Use the *RecoverXL/XLT* only in locations where mechanical ventilation which provides at least four air changes per hour is present, or place the unit 18" above the floor during use.

The *RecoverXL/XLT* should not be used near open containers of gasoline or any other flammable liquid. Do not allow refrigerants to come in contact with open flame. Refrigerant decomposition in flame results in phosgene gas. Breathing phosgene gas can be fatal.
- 8) **Always wear safety goggles and gloves.** Personal protective equipment should be worn to protect operator from frostbite.
- 9) **Use caution when connecting or disconnecting.** Improper usage may result in refrigerant burns (frostbite). If a major leak occurs, proceed immediately to a well ventilated area.
- 10) **Disconnect recovery machine from power before servicing.** An electrical shock hazard is present when the unit is disassembled.
- 11) **Repair damaged parts.** Do not operate the *RecoverXL/XLT* if there is a defective part. Repair the unit to proper operating conditions before further use.

- 12) **Use recommended accessories.** Follow the instructions that accompany all accessories. Improper use may damage equipment or create a hazard.
- 13) **Use the *RecoverXL/XLT* only with the proper refrigerants.** (See specifications for a complete list of compatible refrigerants.)
- 14) **Operate the *RecoverXL/XLT* within the design parameters only.** The *RecoverXL/XLT* was designed to operate within a temperature range of **40° (4° C) to 120°F (49°C)**. Do not operate in a wet location.

Caution: All refrigerant hoses, recovery tanks, refrigerant lines, other vessels containing refrigerants

and the *RecoverXL/XLT* should be handled as if under high pressure. When opening a tank containing refrigerant, open valves slowly to prevent release of refrigerant, especially if the valves might be damaged.

To prevent the risk of fire DO NOT use an extension cord longer than 25' (7.6 m) and a minimum of 16 AWG (1.276 mm²).

RecoverXL Operating Guide

Direct Liquid/Vapor Recovery

The *RecoverXL* is used to pull liquid or vapor refrigerant out of the system and transfer it into a recovery cylinder.

Liquid recovery is accomplished by connecting to the high pressure system discharge service port (liquid port) side of the system being serviced with a manifold (to regulate refrigerant flow).

Vapor recovery can be done by connecting to the system suction service port (low pressure) side of the system.

Because the *RecoverXL* is capable of recovering liquid, it is more efficient to recover all of the liquid, followed by the vapor.

Ensure you have the capacity to recover all the refrigerant in the system. In the USA the recovery cylinders can only be filled to 80% capacity and in the EU it is only 60% capacity.

Refer to the following instructions and the diagram on page 4:

Liquid Recovery

1. Know the type and quantity of refrigerant present before servicing any system.
2. Turn off power to the system being serviced. Turn the selector knob to off.
3. Connect your manifold to the system being serviced. High Side to liquid port and Low Side to vapor port as shown in diagram on page 4.
4. Connect the Utility port of your manifold to the 1/4" SUCTION port of the *RecoverXL*.
5. Connect one hose from the recovery cylinder (liquid side) to the 1/4" DISCHARGE port of the *RecoverXL*.

Note: Be sure to connect hose ends with shut-off to suction and discharge ports of recovery machine. (For best performance use 3/8" hoses.)

6. **Purge all hoses** of non-condensables before recovering refrigerant into recovery cylinder.
7. Open the liquid valve on the recovery tank.
8. Turn the *RecoverXL* on.
9. Turn the selector VALVE on the *RecoverXL* to LIQUID RECOVERY position.
10. Open the High Side and Utility valves on your manifold and use them to regulate the refrigerant pressure to 80 psi maximum.
11. The *RecoverXL* will recover the liquid refrigerant. When you have removed all the liquid in the system switch to vapor recovery procedure step 9 to reduce your recovery time.

Vapor Recovery

1. Know the type and quantity of refrigerant present before servicing any system.
2. Turn off power to the system being serviced. Turn the selector knob to off.
3. Connect your manifold to the system being serviced. High Side to liquid port and Low Side to vapor port as shown in diagram on page 4.
4. Connect the Utility port of your manifold to the 1/4" SUCTION port of the *RecoverXL*.
5. Connect one hose from the recovery cylinder (liquid side) to the 1/4" DISCHARGE port of the *RecoverXL*.

Note: Be sure to connect hose ends with shut-

off to suction and discharge ports of recovery machine. (For best performance use 3/8" hoses.)

6. **Purge all hoses** of non-condensables before recovering refrigerant into recovery cylinder.
7. Open the liquid valve on the recovery tank.
8. Turn the *RecoverXL* on.
9. Turn the selector VALVE on the *RecoverXL* to VAPOR RECOVERY position.
10. Slowly open the valves on your manifold and use them to regulate the refrigerant pressure to 80 psi maximum.
11. The *RecoverXL* will recover the vapor refrigerant. When the suction gauge indicates

the appropriate vacuum, turn the selector valve OFF.

12. Turn selector valve to PURGE position.
13. When the suction gauge again indicates the appropriate vacuum the recovery and purge cycles are complete. Turn the selector valve to OFF and turn the *RecoverXL* off.

Note: If the machine is not recovering, refer to the troubleshooting guide on page 9. Restart procedures are on the side of the machine and on page 5.

Liquid or Vapor Recovery Diagram

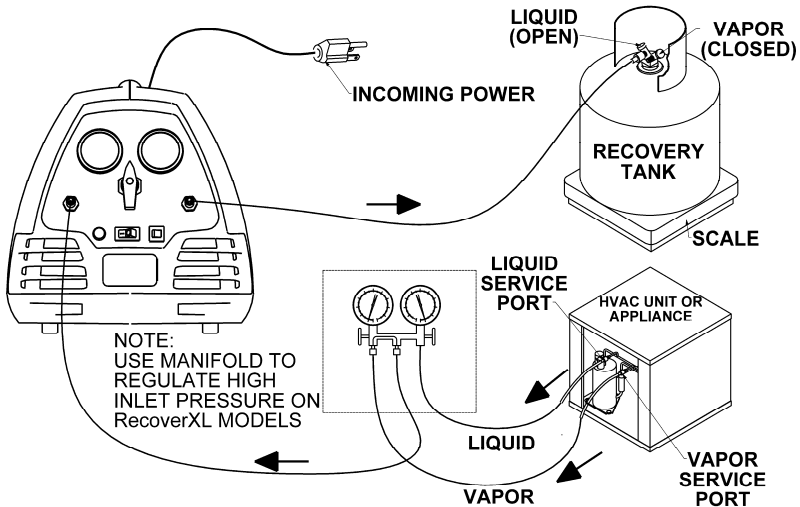

RecoverXLT Operating Guide

Direct Liquid/Vapor Recovery

The *RecoverXLT* is used to pull liquid or vapor refrigerant directly out of the system and transfer it into a recovery cylinder.

Liquid recovery is accomplished by connecting to the high pressure system discharge service port (Liquid Port) side of the system being serviced.

Vapor recovery can be done by connecting to the system suction service port (low pressure) side of the system.

Because the *RecoverXLT* is capable of recovering

direct liquid, it is best to first recover all of the liquid, followed by the vapor. This will make your job easier and faster. Refer to the following instructions and the above diagram:

1. Know the type and quantity of refrigerant present before servicing any system.
2. Turn off power to the system being serviced. Turn the selector knob to off.
3. Connect your manifold to the system being serviced. High Side to liquid port and Low Side

to vapor port as shown in diagram on page 4.

4. Connect the Utility port of your manifold to the 1/4" SUCTION port of the *RecoverXLT*.
5. Connect one hose from the recovery cylinder (liquid side) to the 1/4" DISCHARGE port of the *RecoverXLT*.
Note: Be sure to connect hose ends with shut-off to suction and discharge ports of recovery machine (for best performance use 3/8" hoses.)
6. Purge all hoses of non-condensables before recovering refrigerant into recovery cylinder.
7. Open the liquid valve on the recovery tank.
8. Turn the *RecoverXLT* on.
9. Turn the selector VALVE on the *RecoverXLT* to either the LIQUID or VAPOR position.
10. Open the Utility and either High Side or Low Side valves on the manifold. Remember it is more efficient to recover the liquid refrigerant

first. **Caution: do not over-pressure low side gauge.**

11. The *RecoverXLT* will continue to recover until it reaches and sustains the appropriate vacuum at which point the LOW PRESSURE SWITCH shuts down the unit and the lamp indicates **Recovery Complete**.
12. Turn the system switch off. Turn the selector valve clockwise to OFF. Turn the system switch on. Turn selector valve to PURGE position.
13. When the unit again shuts down and the lamp indicates **Recovery Complete**, the recovery and purge cycles are complete.

Note: If the machine is not recovering, refer to the troubleshooting guide on page 9. Restart procedures are on the side of the machine and below.

Restart Procedure

If the recovery unit was stopped during operation, it may be necessary to balance the internal pressures before the unit will start.

To balance the internal pressure:

- 1) Turn the system switch off.
- 2) Rotate selector clockwise to the OFF position. Allow pressures to balance.
- 3) Turn the recovery machine ON.
- 4) Turn the selector valve counter-clockwise to the previous RECOVER position.

Push-Pull Liquid Recovery

The **Push-Pull Liquid Recovery** mode is used for transferring large volumes of liquid refrigerant. The *RecoverXL/XLT* "pulls" vapor from the recovery cylinder and produces high pressure discharge gas that "pushes" liquid out of the HVAC system and into the recovery cylinder. The auto purge feature makes the reconfiguration to vapor recovery easier and faster to do.

Some HVAC systems will not allow for the push-pull recovery method. If any of the following conditions apply, do not use push-pull method, but follow the instructions on page 3 for the *RecoverXL* and page 4 for *RecoverXLT*.

- System contains less than 10 pounds of refrigerant.
- System is a heat pump or other unit with a reversing valve.
- System has an accumulator between the service ports used in liquid recovery.

- The refrigerant system does not allow for the formation of a solid column of liquid.

For push-pull recovery, a sight glass is monitored during recovery. When liquid is no longer visible, stop recovery and finish recovering using the VAPOR recovery process for *RecoverXL* or *RecoverXLT* as described on page 3 or 4.

When push-pull recovery is complete, a small amount of refrigerant remains in the system. For complete recovery, the system must be pulled into a vacuum as required by EPA standards. This process requires:

- 1) An extra hose for the push-pull recovery.
- 2) A recovery cylinder with about 5 lbs. of refrigerant.
- 3) A sight glass (**Note: Make sure sight glass is rated for the pressure of the refrigerant being recovered**).

Follow these steps:

- 1) Turn off power to the system to be serviced.
- 2) Hook up the **RecoverXL/XLT**, the system to be recovered, and the recovery tank as shown in the diagram below.
- 3) **Purge all hoses** of non-condensables before recovering refrigerant into recovery cylinder.
- 4) Open valves on the recovery tank.
- 5) Turn the selector valve to VAPOR position.
- 6) Turn the **RecoverXL/XLT** on.
- 7) Monitor the sight glass. When the passing liquid is no longer visible through the sight glass, the push-pull method of recovery is complete.
- 8) Close the VAPOR valve on the recovery tank

- and let the recovery continue.
- 9) Turn the selector valve clockwise to the PURGE position and follow procedures for purging the **RecoverXL/XLT**.
- 10) Turn the **RecoverXL/XLT** off.
- 11) Close LIQUID valve on recovery tank.
- 12) Reconnect the hoses per the procedure for the **RecoverXL/XLT** instructions.
- 13) Rotate the selector valve to the VAPOR position.
- 14) Continue recovery until the unit shuts off or reaches the appropriate level of vacuum.

Note: See pages 3-4 for a detailed set of instructions on Vapor Recovery.

Push-Pull Recovery Diagram

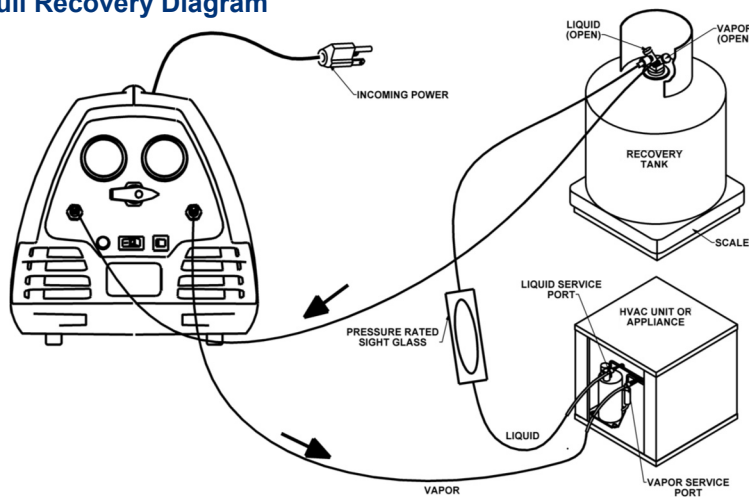

Recovering R-410A High Pressure Gas

IMPORTANT!!! Some equipment should not be used with this refrigerant. Take time to read the safety instructions that came with the device you are servicing as well as any material that came with your refrigerant.

WARNING!!! USE ONLY D.O.T. RECOVERY CYLINDERS APPROVED FOR R-410A.

Overfilling the tank may cause it to rupture!

The **RecoverXL/XLT** will recover R-410A provided the following instructions are followed:

- 1) Set-up for recovery as per diagram on page 4 for normal recovery or page 6 for push-pull recovery.

model.

- 3) Continue recovery until:
RecoverXL - suction gauge indicates the appropriate level of vacuum.
RecoverXLT - Low Pressure Switch has shut the unit off and lamp indicates **Recovery Complete**.
- 4) Turn system switch off.
- 5) Purge the machine (see page 7 for more details).

Technical Support: Call 800-769-8370 for additional information.

Care and Maintenance

Auto Purge Instructions

Purging or evacuating the **RecoverXL/XLT** is one of the simplest and most important functions. Reduce the risk of cross contamination and prolong the life of the **RecoverXL/XLT** by purging after *every* service.

Note: The purge process must be done before disconnecting the discharge hose from the RecoverXL/XLT.

For RecoverXL Models

- 1) The **Low Pressure Switch** will shut the unit off and the lamp will indicate **Recovery Complete** when the unit reaches appropriate vacuum levels. After the unit shuts down, turn the system switch to off, then rotate the selector valve clockwise to OFF to equalize then to PURGE. Turn the system switch on.

Note: The low side gauge should read an increase in suction pressure, indicating the refrigerant that was trapped in the machine. Wait until the **Low Pressure Switch** again shuts the unit off at the appropriate vacuum.

- 2) Close the valve to the recovery tank and shut

the **RecoverXL** off.

For RecoverXL Models

- 1) Monitor the recovery of the system until the suction gauge indicates the appropriate level of vacuum. Turn off and rotate selector valve to OFF to equalize then to PURGE. After the unit shuts down, turn the system switch to off, then rotate the selector valve clockwise to OFF to equalize then to PURGE. Turn the system switch on.

- 2) Turn the system switch on.

Note: The low side gauge should read an increase in suction pressure, indicating the refrigerant that was trapped in the machine. Wait until the suction gauge indicates the appropriate vacuum.

- 3) Turn the selector system switch off
- 4) Close the valve to the recovery tank and shut the **RecoverXL** off.

RECOVERY TIPS AND TECHNIQUES

- 1) To assure the fastest and quickest recovery possible, use the shortest hoses possible and avoid hoses with Schrader depressors.
- 2) Know what kind and the amount of refrigerant that is going to be recovered. This is critical to avoid contamination and know how much refrigerant will be recovered. The first job of the day usually means a fresh, empty tank and no cause for worry about over-filling. However, the last job of the day means there is already liquid in the tank and over-filling can be a concern. Over-filling a recovery cylinder can have disastrous results.
- 3) Refrigerant responds to heat. Therefore, a significant increase in the speed of the recovery process will be obtained if a heat gun is used, specifically to any spots where liquid may have accumulated.
- 4) Always try to recover liquid first. This is the preferred method of recovery for the **RecoverXL/XLT**, which pumps liquid 5 to 7 times faster in standard liquid mode than vapor.
- 5) If recovering large amounts of refrigerant (20 lbs or more), the push-pull method is recommended. (**Note: This process requires the hoses to be switched before recovery of the remaining vapor.**)
- 6) Recovery can often be speeded up by simultaneous recovery from both the high and low side of the system. Attach short hoses to both the high and low side of the system and join them with a BRUTE™ II Manifold or Y connector to the hose going to the Suction Port of the **RecoverXL/XLT**.
- 7) Protect the **RecoverXL/XLT** by keeping the built-in suction filter **IN THE MACHINE**. Failure to use the suction filter in the **RecoverXL/XLT** will void the warranty.
- 8) Recovery machines are not vacuum pumps. For proper evacuation, use a YELLOW JACKET SuperEvac™ vacuum pump. To speed up the evacuation process, use the SuperEvac vacuum pump and a core removal tool (Part #18975). For more information contact your YELLOW JACKET wholesaler.

Components

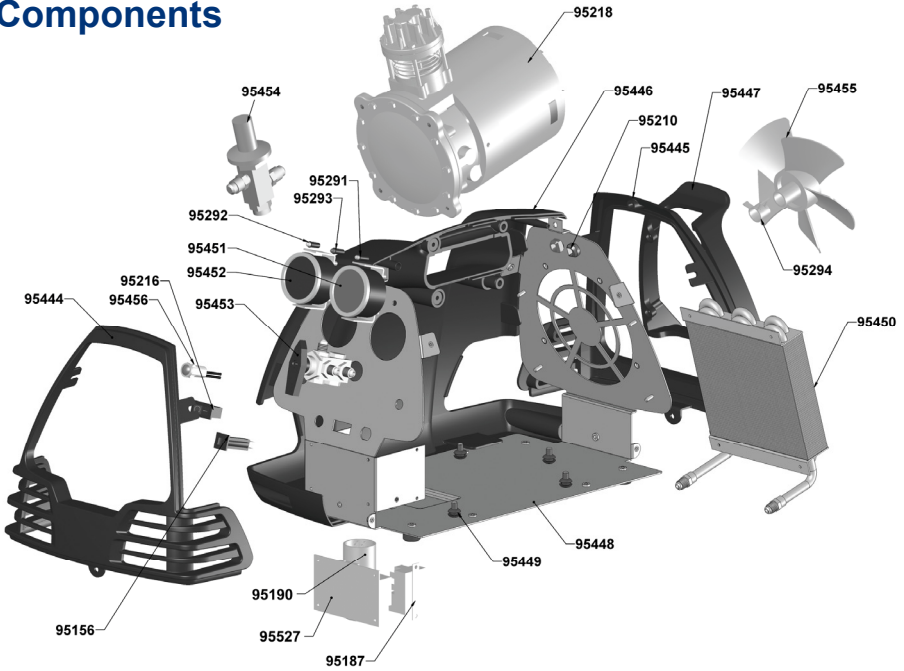

RecoverXL/XLT Parts

Part#	Description	Part#	Description
95444	Case, Front	95216	Rocker Switch
95445	Case, Rear	95453	Manifold Assembly
95446	Case Half (both halves)	95228	CPR Valve
95447	Case, Cord Wrap	95455	Fan Blade
95448	Aluminum Frame	95294	Fan Clip
95449	Compressor Bracket Grommet	95451	High Pressure Gauge
95450	Condenser Coil	95452	Low Pressure Gauge
95325	High Pressure Switch (XLT w/ TOS)	95210	Large Cord Strain Relief Bushing
95547	High Pressure Switch (XL/XLT w/o TOS)	95190	Capacitor
95338	Low Pressure Switch (XLT Only)	95457	Replacement Filter Screen



RecoverXLT w/TOS Parts Only

Part#	Description
95477	TOS LED Strip Assembly
95478	TOS LED Connection Cable
95527	TOS Board for <i>RecoverXLT</i> (board, LED strip and cable)
95248	Umbilical Cord Overfill Sensor
95188	Shorting Cap for Umbilical Cord

Troubleshooting Guide

Condition	Possible Problem	Possible Solution
No power to unit	Power cord not plugged in	Plug power cord in
	Outlet not energized	Reset breaker
Compressor will not start	Compressor under unequalled conditions	See restart procedure
	Compressor thermal overload is tripped	Thermal overload will reset in approx. 15-30 minutes
	Unit is shut down on Recovery Complete.	Low pressure switch resets at atmospheric pressure, rotate selector valve to either the Vapor or Liquid Recovery position.
	Unit is shut down on tank full or high pressure.	Check tank pressure, check for restrictions, check shorting cap or umbilical connection, and check high gauge pressure to see if unit is under high pressure.
Unit runs but shuts off after short time	Restriction on discharge side tripping the high pressure switch	Check for restrictions 1) Tank valves 2) Schrader cores
		Selector valve in correct position
Unit trips breaker upon start up	Compressor is under unequalled conditions	See restart procedure
Unit runs but does not recover refrigerant	Suction filter clogged	Clean or replace suction filter
	Selector valve in wrong position	Put selector valve in liquid or vapor recovery position
Unit will not pull a vacuum	Hoses are not tight	Tighten hoses
	Leak in HVAC/R system	Find and repair leak in system
Unit running sluggish	Low voltage to unit	Check power supply
Vacuum switch won't reset	Switch needs to reset	Pressurize inlet port

Components, cont.

	Domestic Models 115 V		International Models 230 V
Part#	Description	Part#	Description
95218	Oil-less Compressor 115V, 60Hz	95264	Oil-less Compressor 230V, 50Hz
95156	Circuit Breaker - 12 AMP	95429	Circuit Breaker - 6 AMP
95215	Power Cord, Domestic**	95430	230V Amber Lamp (<i>RecoverXLT</i> only)
95456	Neon Lamp, 115V (<i>RecoverXLT</i> only)	95266	Compressor Relay, 230V
95187	Compressor Relay, 115V	95459	IEC 320 Power Socket **
		95431	Power Cord, 230V CE*
		95432	Power Cord, 230V UK*

*If the detachable power cord is damaged (95431 or 95432), it must be replaced by a cord assembly available from the manufacturer or distributor where purchased.

**If the attached power cord or socket is damaged (95215 or 95459), it must be replaced by the manufacturer or its authorized service center in order to avoid hazard.

TECHNICAL DATA

Compressor:		1/2 HP Reciprocating Oil-Less	
Power Source:		115V AC 60 Hz 1 Phase	230V AC 50 Hz 1 Phase
Amperage:	Run Load Amps:	9.3	3.7
	Full Load Amps:	11.0	11.0
	Locked Rotor Amps:	30.0	18.0
Size:	Height:	12.50"	
	Width:	12.50"	
	Depth:	19.25"	
	Weight:	29.90"	

**UL Certified Rates to ARI Standard 740-98*

RecoverXL	R-12	R-134a	R-22	R-500	R-502	R-410A
Vapor lbs./min	.31	.31	.31	.31	.55	.42
Liquid lbs./min	1.68	1.68	1.68	1.68	2.29	1.41
Push-Pull lbs./min	13.12	13.12	13.12	13.12	13.18	11.6
Vacuum Level	15 inHg	15 inHg	15 inHg	15 inHg	15 inHg	15 inHg
RecoverXLT	R-12	R-134a	R-22	R-500	R-502	R-410A
Vapor lbs./min	.37	.37	.37	.37	.66	.42
Liquid lbs./min	1.98	1.98	1.98	1.98	2.65	1.68
Push-Pull lbs./min	12.81	12.81	12.81	12.81	12.9	11.6
Vacuum Level	15 inHg	15 inHg	15 inHg	15 inHg	15 inHg	15 inHg

Other Refrigerants - The *RecoverXL/XLT* is approved for use with the following refrigerants which have not been certified for a particular recovery rate: R401B, R-402A, R-402B, R-404A, R-406A, R-407A, R-407B, R-407C, R-407D, R-408A, R-409A, R-411A, R-411B, R-500 and R-502.

Suction Filter

The *RecoverXL/XLT* is equipped with a built-in particulate strainer located behind the suction port. Unscrew the suction port by using a 11/16 wrench to unscrew the hex head port to remove. This prevents contaminants, copper shavings, carbon, and other foreign objects from making their way to the *RecoverXL/XLT* compressor and causing permanent damage.

Like a filter drier, this strainer **MUST** be cleaned or replaced often. Failure to do this can cause the strainer to become too clogged for refrigerant to flow freely. A sure sign that the straining device is

clogged is the freezing of the suction port and the filter cover.

Before replacing, check the condition of the o-ring. Replace if necessary.

Note: Make sure to use a strainer in the RecoverXL/XLT for every job! Filter strainers and o-rings are available from your supplier.

Filter Strainer and O-Ring - Part #95457

Wiring Diagrams

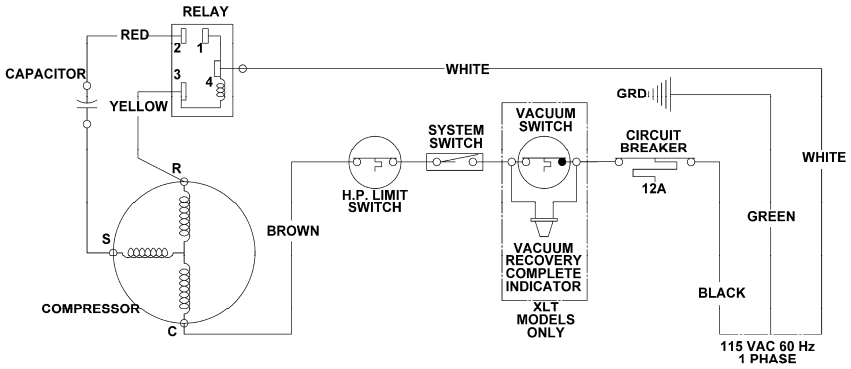

Domestic RecoverXL/RecoverXLT

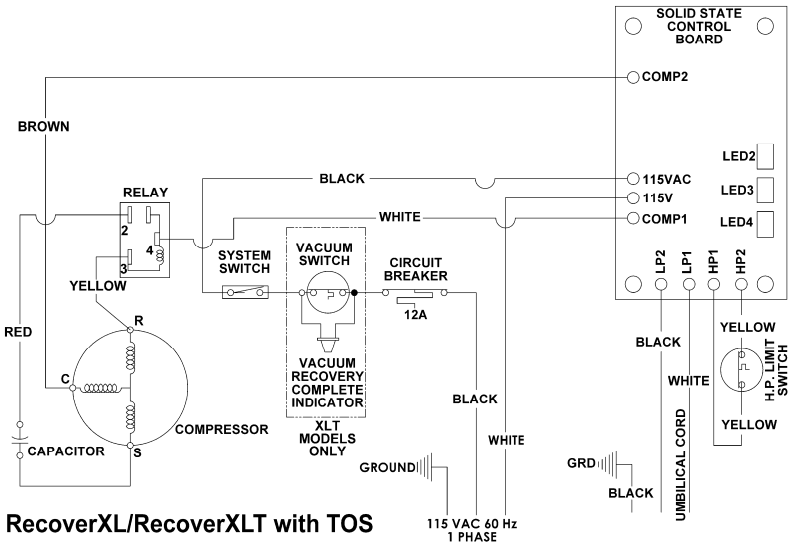

RecoverXL/RecoverXLT with TOS

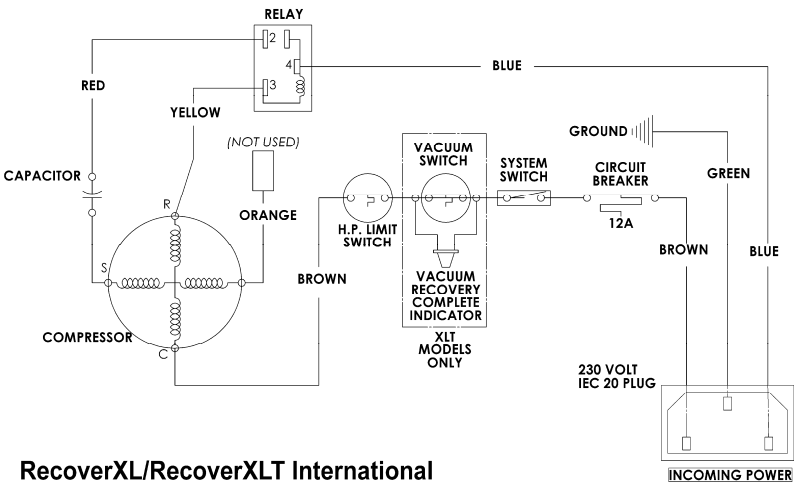

RecoverXL/RecoverXLT International

IMPORTANT NOTICE TO PURCHASER

Check for damage immediately. Prior to shipment, all YELLOW JACKET *RecoverXL/XLT* Refrigerant Recovery Systems are completely tested and inspected to assure compliance with Ritchie Engineering factory specifications.

If the recovery system carton is damaged, check contents immediately. Note damage on shipper's Bill of Lading and have shipper sign statement. Notify carrier immediately of the damage to arrange inspection of the recovery system and packaging. The CARRIER ALONE is responsible for handling and settling your claim. Ritchie Engineering will cooperate in assessing damage if

the recovery system is returned to the factory prepaid.

Carton contents include:

- *RecoverXL or RecoverXLT* Refrigerant Recovery System
- Owner's manual
- Warranty registration card

To validate warranty, mail registration card within 10 days.

WARRANTY INFORMATION

Ritchie Engineering guarantees YELLOW JACKET products to be free of defective material and workmanship which could affect the life of the product when used for the purpose for which it was designed. Warranty does not cover items that have been altered, abused or returned solely in need of field service maintenance.

YELLOW JACKET recovery products (UPC 957xx) are covered by a one year warranty for parts and labor. The 115V recovery products (UPC 95760 and 95762) have an extended three year compressor warranty if the warranty card is returned and on file. The warranty also allows for a one year over-the-counter exchange, when applicable. To receive this over-the-counter exchange, call Ritchie Engineering Customer Service at (800)769-8370 and get the required authorization number. Failure to get the required authorization number could result in a denial of the over-the-counter exchange.

Note: All units must be shipped to the Bloomington, MN plant for repair. If at any time after the warranty period you have problems with your YELLOW JACKET recovery unit, call

The following exceptions will not be covered under this warranty: Recovery products that have been altered, misused, or improperly maintained.

The following must be done before returning unit:

- 1) Call our technical service personnel at (800) 769-8370 to assess if the problem can be resolved over the phone.
- 2) Obtain an RGA number from Ritchie Engineering for the return of the product.
- 3) Fax a copy of the original invoice to (800) 322-8684.

our technical service department for help in selecting the correct replacement parts, or to arrange for its repair at reasonable costs.

