

RH/RHT Series

Relative Humidity and Temperature Transmitters



The Relative Humidity (RH) and Temperature transmitters are designed for continuous monitoring of relative humidity (RH) or relative humidity and temperature (RHT). They provide accurate and reliable measurement for building automation and environmental control systems. The units feature very low profile sensor enclosures that are virtually unnoticeable in most installations.

The RH and RHT transmitters are available with $\pm 2\%$, $\pm 3\%$, and $\pm 5\%$ RH accuracy (20% to 95% RH). For monitoring and controlling in critical environments, the units can be precision calibrated to 1% accuracy within a specified RH range.

The RH and RHT transmitters provide a linear output of 4-20 mA corresponding to 0 to 100%RH. The RHT transmitter also provides a 4-20 mA signal corresponding to any of the selected standard temperature ranges specified.

Features

- Space, Duct, and Outside Air Configurations
- Durable Industrial Enclosures
- Low Profile
- Compact
- Replaceable, Plug-in Bulk Polymer Resistance RH Sensor
- Resistant to Contamination
- Temperature Compensation



Sensor Enclosure

The relative humidity and temperature sensors are housed in heavy duty, compact, locking enclosures. Enclosures may be removed and painted, which further helps blend them into any environment.

Sensor

The RH sensor incorporates a bulk polymer resistive element. The polymer is impervious to most contaminants and, since it is a bulk resistance device, surface contamination such as dust will not alter the accuracy of the readings. Imbedded in the polymer is an interdigitated grid which senses resistance change as the polymer absorbs or emits molecules of water.

Transmitter

The electronics are contained in a rugged pressure-cast aluminum weatherproof housing designed for maximum protection. Continuous temperature compensation adjusts for temperature-induced change in the RH sensor output. The compensation provides high measurement accuracy over the entire operating range of the instrument.

Dimensions and Mounting

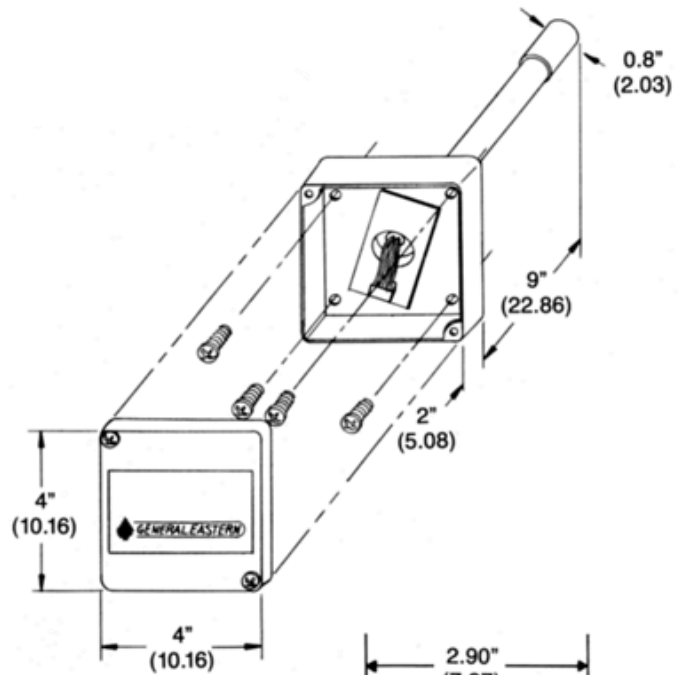

Mounting Template

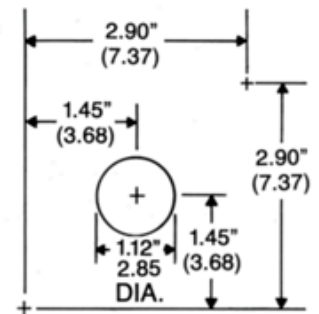

RH and RHT Duct Mount

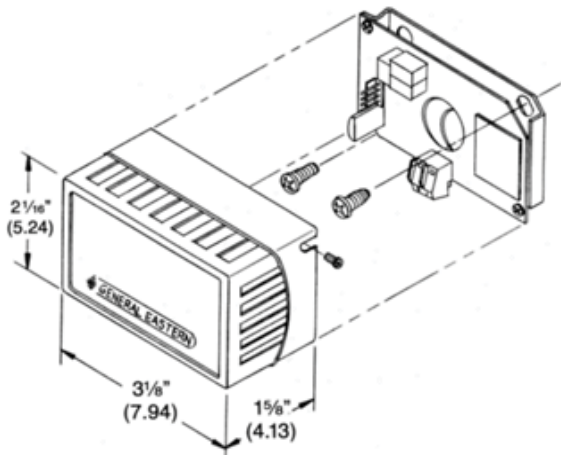

Mounting Template (Side View)

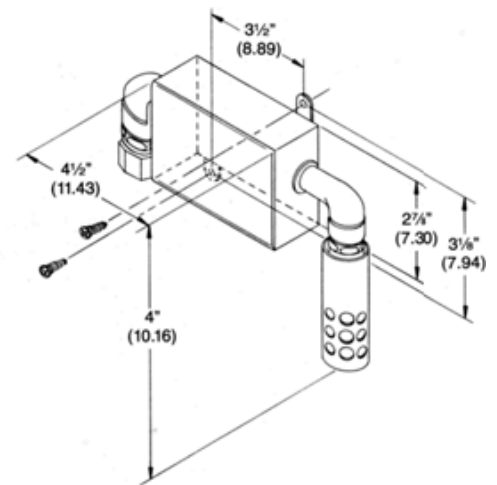
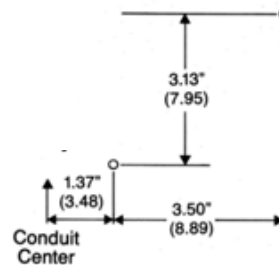

RH and RHT Outside Air Mount

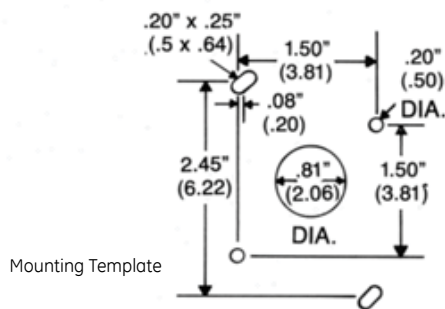

Mounting Template

RH Space Mount

Wiring Guidelines

Outputs: Relative Humidity

4-20 mA Current Output

The 4-20 mA transmitters will provide a linear proportional signal with 4 mA corresponding to 0% RH and 20 mA to 100% RH. These are loop powered devices; therefore, only two wires are required.

0-5 Volt Voltage Output

The 0 to 5 volt transmitters provide a linear proportional output at terminal "O" with 0 volts equivalent to 0% RH and 5 volts to 100% RH.

The voltage output transmitters can be wired as a three wire transmitter or as a four wire transmitter to eliminate the effects of wire length. The output voltage is with respect to Terminals "N" (power supply return) and/or "G" (signal ground) which are common at the transmitter.

Output: Temperature (Optional)

The temperature option (if ordered) is a separate circuit board but mounted in the same housing along with the relative humidity transmitter.

The 4-20 mA transmitters output is linear and proportional to the range specified when the transmitter was ordered. The low range temperature (4 mA) is marked on the ZERO pot and the high range temperature (20 mA) is marked on the SPAN pot. Standard range is - 20° to 140°F (this range is supplied when no range is specified at time of ordering).

The temperature transmitters are entirely separate circuits from the RH transmitters. Transmitters are loop powered devices. Therefore, only two wires are required. One wire may be common with the RH transmitter.

Wiring

Wiring for the transmitter should be twisted pair(s) 16-22 AWG approximately 2 turns per inch. In installations near electric motors or sensitive electronic equipment, use shielded cable. Wiring should be run through conduit using the 1/2" EMT compression fitting supplied on the unit.

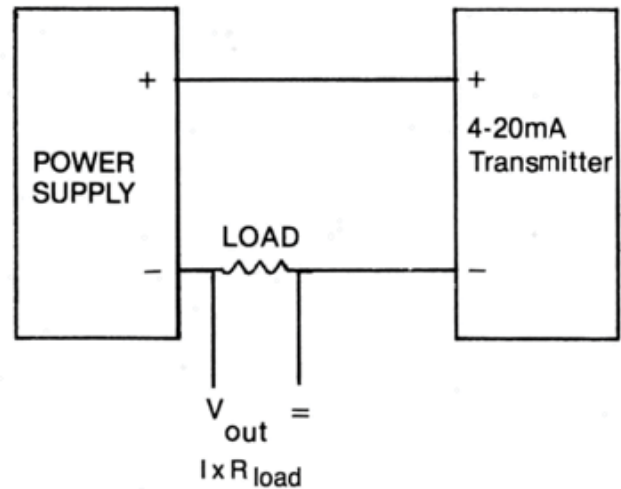

Wiring Diagram Current Unit

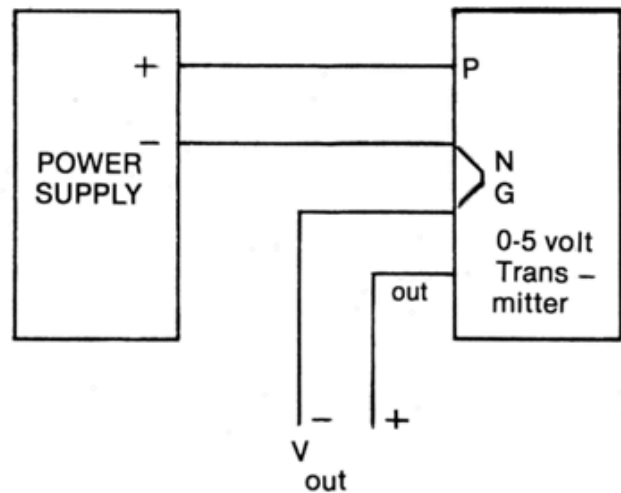

Wiring Diagram Voltage Unit

RH/RHT Specifications

Humidity

Sensing Element

Resistance change of bulk polymer sensor

Performance

Accuracy at 77°F (25°C)

±2% RH, 20-95% RH

±3% RH,, 20-95% RH

±5% RH, 20 -95% RH

including hysteresis, linearity and repeatability

Mechanical: Case Material

Space: ABS Flame Retardant

Duct: Galvanized Steel

Outside Air: Pressure Cast Aluminum and Galvanized Steel

Mounting Configurations

Space, Duct, Outside Air

Temperature Effect

Less than 0.06% per °F (0.11% per °C)

Sensitivity

0.1% RH

Repeatability

0.5% RH

Linearity

See Accuracy

Hysteresis

Less than 1%

Sensor Interchangeability

±3% nominal

Operating Range

RH Sensor: 0%-99%, RH, non-condensing.

-40°F to +170°F (-40°C to +76°C)

Electronics: 0%-95% RH, non.condensing.

-40°F to +130°F (-40°C to +54°C)

Max. Air Velocity

10,000 ft/min

Output Range

2-wire. isolated loop, powered 4-20 mA, 0-100% RH (standard)

Adjustment

Zero: ±20%, non-interactive

Span: ±10%, non-interactive

Long Term Stability: Less than 1 % drift/year typical

Power

Supply Voltage

12-36 VDC

Max Load

$$\Omega = \frac{\text{Supply} \cdot 10 \text{ VDC}}{0.02 \text{ A}}$$

Storage Temperature

-85°F to +158°F (-65°C to +70°C)

RH/RHT Specifications

Temperature

Sensing Element

Platinum RTD, 4 wire measurement

Performance

Accuracy at 77°F (25°C)

±0.5°F (±0.3°C)

Temperature Effect

Less than 0.01% per °F (0.02% per°C)

Sensitivity

0.1% RH

Repeatability:

0.1% RH

Linearity

Better than 0.1 %

Hysteresis

Less than 0.01%

Sensor Interchangeability

±0.5°F (±0.03°C)

Output Ranges

4-20 mA

- 20°F to + 140°F (-29°C to +60°C)

Optional

0°F to +150°F (-18°C to +66°C)

0°F to +100°F (-18°C to +38°C)

+32°F to +132°F (0°C to +55°C)

+50°F to +130°F (+7°C to +54°C)

-40°F to + 140°F (-40°C to +60°C)

Custom range

Adjustment

Zero: ±10%. non-interactive

Span: ±10%. non-interactive

Long Term Stability: Less than 1% drift per year, typical

Humidity affects you and your operations. Our local representative is ready to help in your application. Call to discuss the proper selection of a humidity device from the world's largest selection.

Specifications are subject to change without notice.

Ordering Information

Model RH

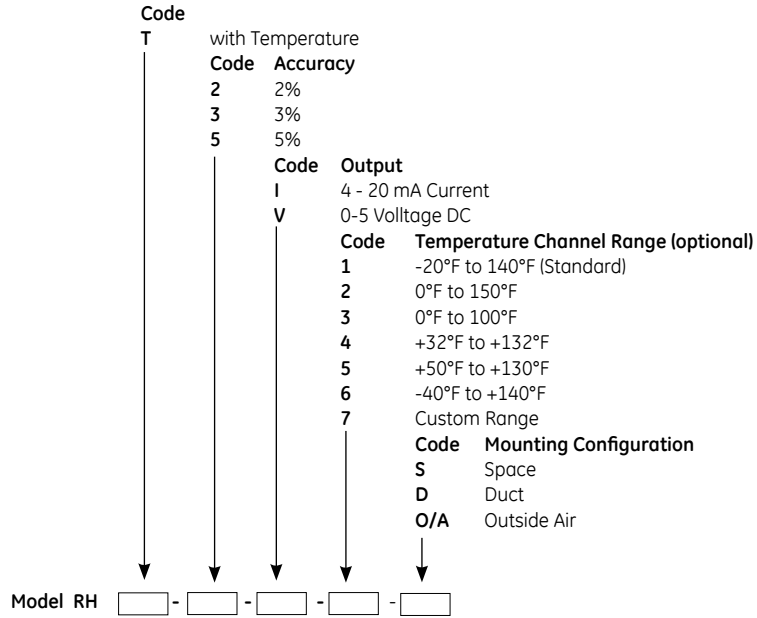

Example 1: To specify an RH transmitter, order: **RH-2-I-S**.

Example 2: To specify an RH transmitter with optional temperature sensor with standard range (-20°F to + 140°F), order: **RHT-2-I-S**.

Options

Special calibration to $\pm 1\%$ accuracy (20% RH span in 20%-- 95% RH range)



Test Equipment Depot
1-800-517-8431

99 Washington Street
Melrose, MA 02176
Phone 781-665-1400
Toll Free 1-800-517-8431

Visit us at www.TestEquipmentDepot.com

920-509A