

RXW Pulse Input Sensor (RXW-UCx-xxx) Quick Start

Adding a Sensor Node to the HOBOnet® Wireless Sensor Network

Important: Keep the sensor node near the station while completing these steps.

If you are setting up a new station, follow the instructions in the station quick start guide before setting up this sensor node (go to www.onsetcomp.com/manuals/24500-rx2105-and-rx2106-manual for RX2105 and RX2106 stations or www.onsetcomp.com/manuals/rx3000-qsg for RX3000 stations).

1

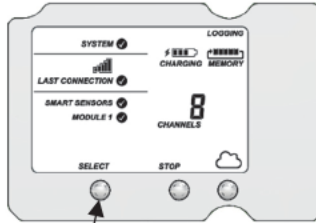

Press the Select button on the station to switch to the module with the manager (module 2 on RX2105 or RX2106 stations).

2

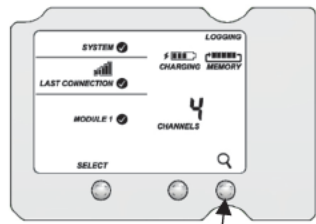

Press the Search button. The magnifying glass icon blinks while the station is in search mode waiting for sensor nodes to join the network.

3

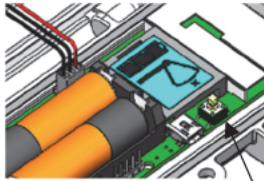

Open the sensor node door and install the rechargeable batteries. Press this button on the sensor node for 3 seconds.

4

Watch the sensor node LCD during the process of joining the network:

a.



This signal strength icon blinks while searching for a network.

b.



Once a network is found, the icon stops blinking and the bars cycle from left to right.

c.



This network connection "x" icon blinks while the sensor node completes the registration process, which may take up to five minutes.

d.



Once the sensor node has finished joining the network, the "x" icon is no longer displayed and the channel count on the station LCD increases by two (one for the pulse input sensor and one for the sensor node battery).

5

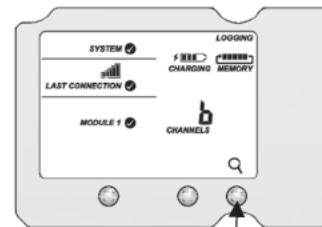

Press the Search button on the station again to stop the search for sensor nodes.

6



Go to www.hobolink.com to monitor sensor node status and health. See the HOBOLink Help for details.

Installing the Bracket and Sensor Node

1

Orient the bracket so the text TOP is facing upwards.

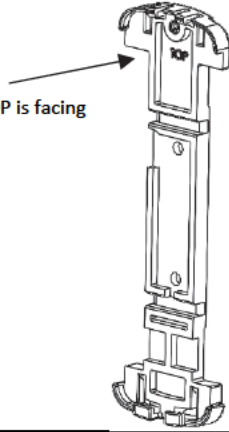

2

To install the bracket onto a wall, use the two long screws included in the package. Screw the bracket to a wall using the two holes on the mid-section of the bracket.

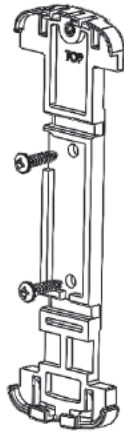

3

To install the bracket onto a pole, slip a cable tie through each of the channels on the bracket and fasten the tie around the pole.

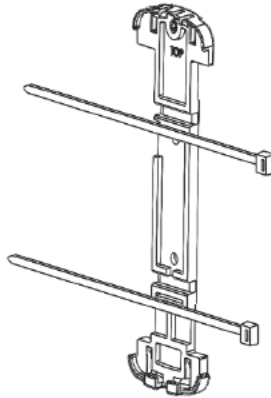

4

Insert the bottom of the sensor node into the retaining clips on the bottom of the bracket then press the top of the sensor node into the clips at the top of the bracket.

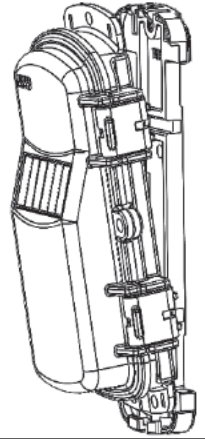

5

Use the short screw included in the package to fasten the sensor node to the bracket.

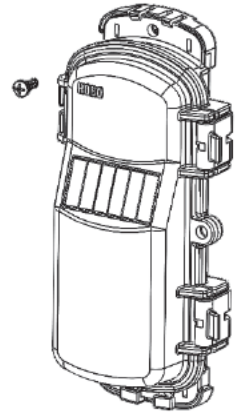

6

Close the sensor node and use a padlock to keep it secure. **Note:** Ensure that the node seal is clean from foreign debris.

Mounting and Positioning the Sensor Node

- Position the sensor node towards the sun, making sure the solar panel is oriented so that it receives optimal sunlight throughout each season. It may be necessary to periodically adjust the sensor node position as the path of the sunlight changes throughout the year or if tree and leaf growth alters the amount of sunlight reaching the solar panel.
- Make sure the sensor node is mounted a minimum of 1.8 m (6 feet) from the ground or vegetation to help maximize distance and signal strength.
- Consider using plastic poles such as PVC to mount the sensor node as certain types of metal could decrease the signal strength.
- Place the sensor node so there is full line of sight with the next sensor node. Use a repeater if there is an obstruction between sensor nodes.
- There should not be more than five sensor nodes in any direction from a repeater or the manager. Data from sensor nodes travels or “hops” across the network and may not reach the station if the sensor node is more than five hops away.

Input Connections

The pulse input sensor has two input connections. The white wire (+) is powered at 3.3 V through a 100 K Ω resistor. This power is supplied from the sensor node battery. The black wire (-) is connected to the sensor node’s ground connection. The input cable can be connected directly to screw terminals on the sensor or to sensor cables with the included wire nuts.

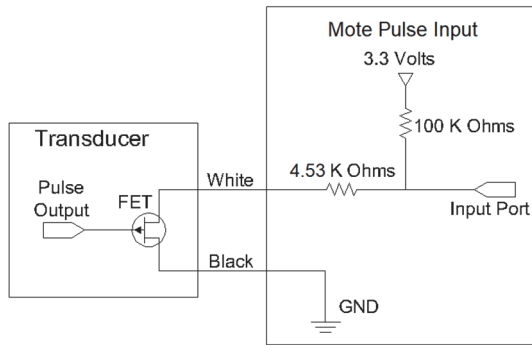

Wiring for RXW-UCC Pulse Input

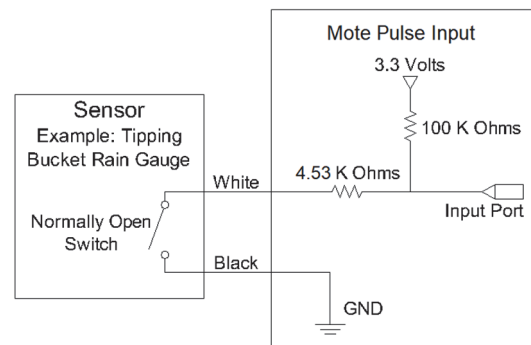

Wiring for RXW-UCD Pulse Input

Connection Using Wire Nuts

Important: If using wire nuts, make sure the connection is protected from the elements.

1. Strip 1 cm (0.39 in.) of insulation from the end of wires, taking care not to nick the metal conductors.
2. Twist the stripped wires together clockwise and then screw on the wire nut clockwise.
3. Check the connection by gently pulling on the wires to verify a solid mechanical connection. Always strain-relief the connection to make sure that the connection is not broken by being jerked or repeatedly worked back and forth.

Pulse Input Sensor Mounting Guidelines

- Coil and secure excess cable with cable ties.
- If cable is on the ground, use a conduit to protect against such things as animals, lawn mowers, and exposure to chemicals.
- When making a connection to a third-party sensor, take time to make sure that the connection is reliable and protected from rain, dirt, and direct exposure to the elements. Refer to the manufacturer’s product documentation for additional information on system configuration.