

SGD 24-M-IP

Waterproof PanelPilot-Compatible Smart Graphics Display



Features

- 2.4" colour TFT screen
- IP-67 and NEMA 6 rated
- Rugged and scratch resistant Corning® Gorilla® Glass window
- Supplied with free Windows design software, to setup and customise the display. Compatible with Windows 7, 8.1 and 10.
- Download meter applications from the ever expanding online library
- Programmable with the USB interface
- Simple and easy panel mounting solution
- IP-67 12-way connection
- Wide operating voltage of 4V – 30V d.c.
- 0 – 40V d.c. measurement range
- 2 analogue inputs & 2 alarm outputs
- SPI and I²C
- 4-20mA version available (SGD 24-M-IP420)



The SGD 24-M-IP is a PanelPilot Compatible IP-67 graphics display with a 320 x 240 pixel (QVGA) colour display and USB programming interface.

Using the PanelPilot software (available for Windows 7, 8.1 and 10), users are able to choose from an ever-increasing number of configurations which can then be customised to their needs. The additional voltmeter types and other functions are available online.

Colours, text labels, splash screen and input voltage scaling can all be customised by the user through the software and then uploaded to the SGD 24-M-IP through the USB connection. When setup is complete, the settings can be saved and then uploaded to the meter using the supplied USB cable. Panel or enclosure installation of the finished module is simple, using the 32mm nut and the IP67 connector supplied with the unit.

Specifications

	Minimum	Typical	Maximum	Unit
Accuracy		0.05	0.1	%
Linearity			±1*	Count
Sample rate		3		Samples/ second
Operating temperature range	0 (+32)		+40 (+104)	°C (°F)
Supply voltage	4		30	V d.c.
Measurement voltage (single ended only) **	0		40	V d.c.
Measurement current (4-20mA version)	4		20	mA
Supply current ***	35		190	mA

* Depending on user calibration settings

** The SGD 24-M-IP uses a programmable gain amplifier. There are 8 different voltage ranges, to optimise the resolution. See page 2 for details.

*** Voltage dependent. See graph on Page 2.

Ordering Information

Standard Display (Panel meter, fixing kit, IP-67 connector, quick start guide)	SGD 24-M-IP
Current Loop Display (Panel meter, fixing kit, IP-67 connector, quick start guide)	SGD 24-M-IP420
USB Cable (Type A to mini-B)	CABLE USB A-MF
2m Rightangle cable with IP-67 connector	CABLE IP-12W-RA



99 Washington Street
Melrose, MA 02176
Phone 781-665-1400
Toll Free 1-800-517-8431



Issue 6 04/2018 Page 1 of 6

SGD 24-M-IP

Waterproof PanelPilot-Compatible
Smart Graphics Display



IP67 Connection

Connector Pin Functions

- | | | |
|----|-----------|---|
| 1 | ESPI-CS2 | - SPI chip select |
| 2 | ESPI-MISO | - SPI master input, slave output |
| 3 | ESPI-CLK | - SPI serial clock |
| 4 | ESPI-MOSI | - SPI master output, slave input |
| 5 | SDA | - Serial data |
| 6 | SCL | - Serial clock |
| 7 | ALM2 | - Alarm output 2 |
| 8 | ALM1 | - Alarm output 1 |
| 9 | IN1 | - Analogue voltage input 1 (maximum of 40V d.c. w.r.t 0v) |
| 10 | IN2 | - Analogue voltage input 2 (maximum of 40V d.c. w.r.t 0v) |
| 11 | 0V | - 0V power supply input |
| 12 | V+ | - Positive power supply input (4V – 30V d.c.) |

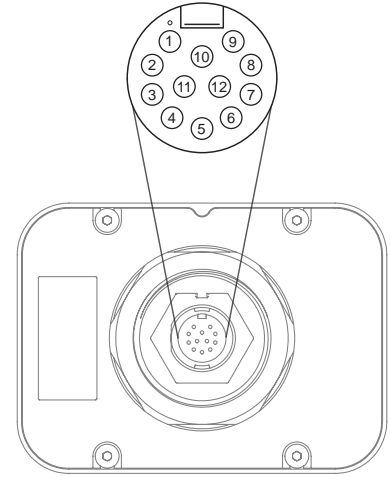

Connector plug options

Twist lock, field installable connector with solder bucket pins.
Seals for Cable OD=4.5mm~7.0mm

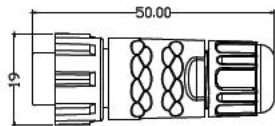

Twist lock connector with right angle overmoulded strain relief.
Cable length 2m.

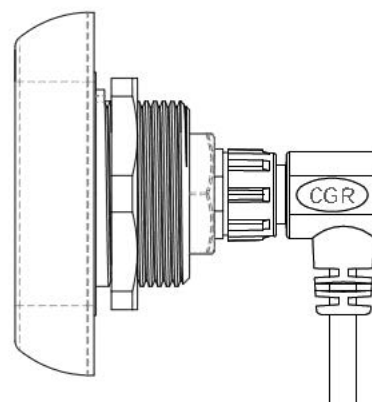
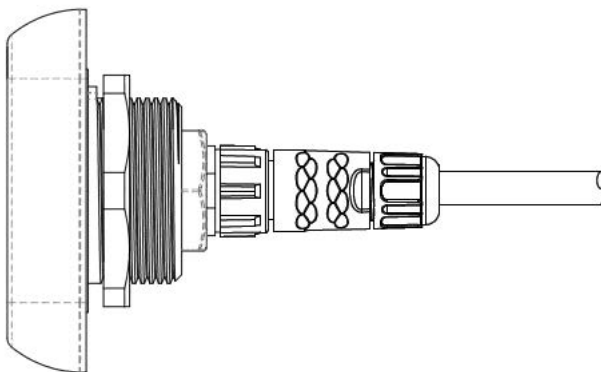
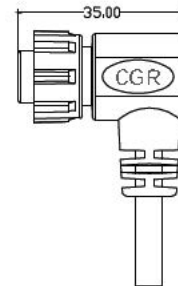

SGD 24-M-IP

Waterproof PanelPilot-Compatible
Smart Graphics Display



Voltage Input

The SGD 24-M-IP features 2 voltage inputs, which use a Programmable Gain Amplifier (PGA) to make the best use of available resolution (the smallest voltage range offers the highest resolution)*. Each channel can be programmed independently, with the option of eight different input voltage ranges:

Voltage Range (V)	Resolution (mV)
0 - 1.25	0.3
0 - 2.5	0.6 (4-20mA)
0 - 4	1.0
0 - 5	1.2
0 - 8	2.0
0 - 10	2.4
0 - 20	4.9
0 - 40	9.8

The input voltage range is decided using the two voltages that the user enters in the scaling section of the Panel Pilot software. The software uses the smallest range available, which can accommodate both of the voltages entered by the user. The absolute maximum voltage input is 40V d.c.

For example:

Entering a voltage scale of 0 – 30V in the software will use the 0 – 40V range.

Entering a voltage scale of 0 – 3V in the software will use the 0 – 4V range.

Entering a voltage scale of 5 – 15V in the software will use the 0 – 20V range.

Note: V+, IN1 and IN2 share a common ground (i.e. not floating or isolated from each other).

*For the 4-20mA model, the 0-2.5 range is used.

Typical Supply Current

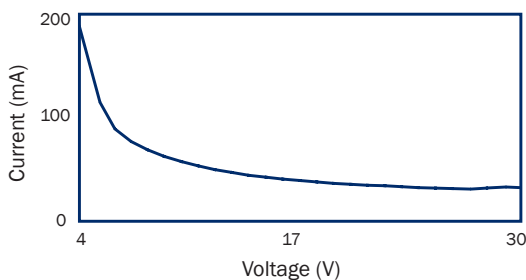

USB Connection

A 'Type A to Mini-B' USB cable is required to program and customise the SGD 24-M-IP by unscrewing the 4xM3 screws and removing the back cover. The packing tray supplied can be used as a jig to hold the module and to avoid disconnecting the 12 way connector from the PCB inside.

The device will be powered for programming via USB.

It typically takes between 10 and 30 seconds to send a configuration, with an additional 5 seconds needed for the hardware to reset.

Display

The display is a 2.4" TFT panel, with a resolution of 320 x 240 pixels and a 16-bit colour depth. Any graphics that are uploaded to the meter are automatically converted to this specification.

SGD 24-M-IP

Waterproof PanelPilot-Compatible Smart Graphics Display



Panel Mounting

The SGD 24-M-IP can be fitted into panels of up to 10.5mm deep. A rubber seal is included to seal the mounting hole when the 32mm nut is fully tightened. Panel mounting hole cut-out is DIA 33mm.

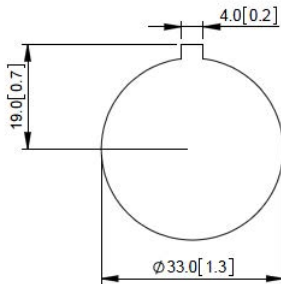
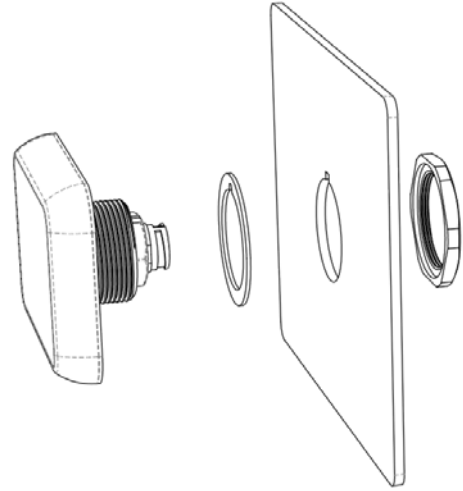

PANEL CUT OUT DIMENSIONS

Dimensions

All dimensions in mm (inches)

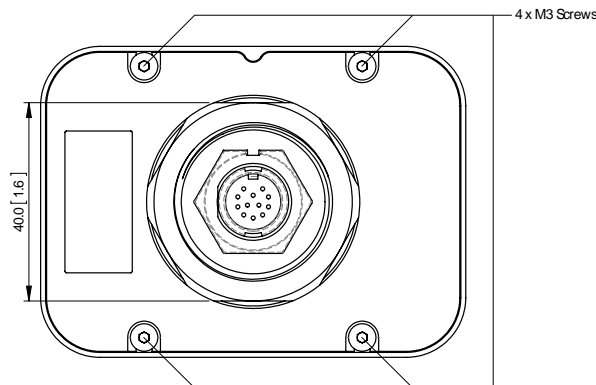
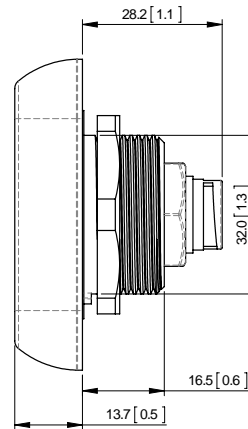
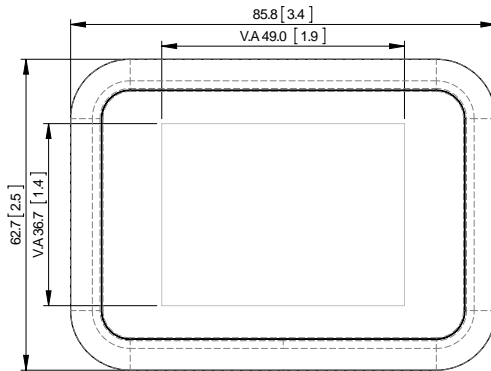

SGD 24-M-IP

Waterproof PanelPilot-Compatible
Smart Graphics Display



Various Operating Modes

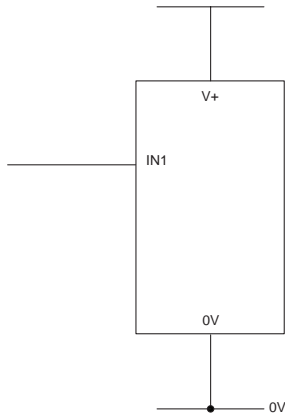

MEASURING A VOLTAGE SOURCE

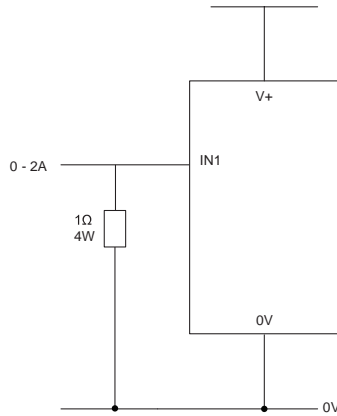

MEASURING 0-2 AMPS CURRENT RANGE

Use a 1Ω resistor, with a 4W rating.
Setup scaling in software: 0V = 0.00 and 2V = 2.00

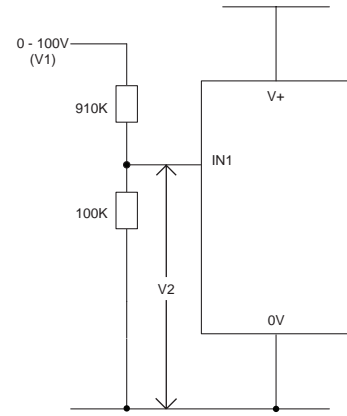

MEASURING 0-100V (d.c. only)

Input a known voltage of between 0 and 100V (V1)
Measure the voltage between IN1 and 0V (V2)
Setup scaling in software: 0V = 0.0
V2 = V1 (Enter with the same number of decimal points, i.e 50.0)

Various Operating Modes (4-20mA version)

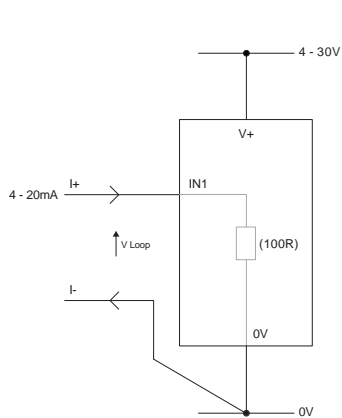

MEASURING 4-20mA

Power supply to meter must be fully floating
(isolated from the 4-20mA current loop)

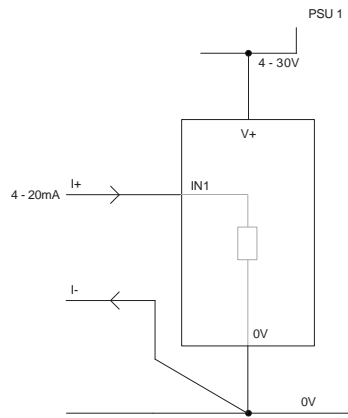

USING TWO SGD DISPLAYS IN SAME INSTALLATION

Each SGD must be powered from a separate,
fully floating, power supply

SGD 24-M-IP

Waterproof PanelPilot-Compatible
Smart Graphics Display



Various Operating Modes (4-20mA version) continued

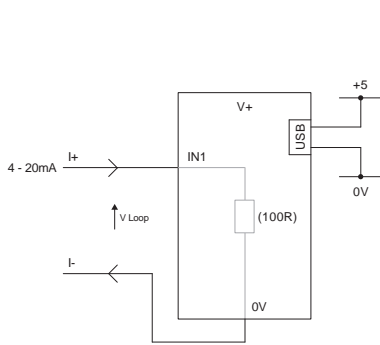

MEASURING 4-20mA
USING A USB POWER SUPPLY

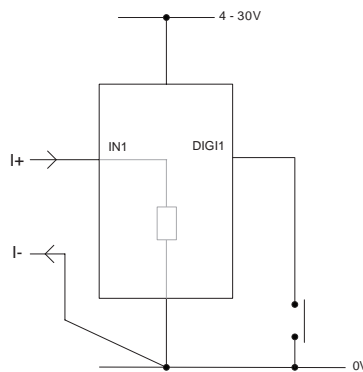

DIGITAL HOLD
DIGI1 will hold the display

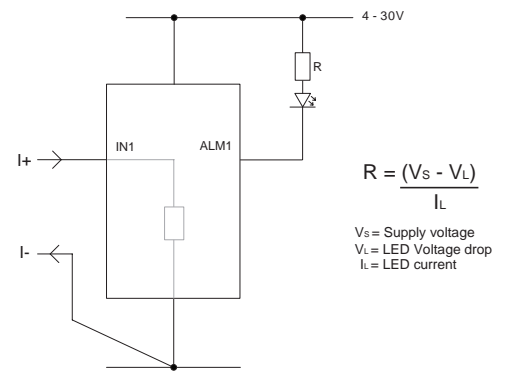

$$R = \frac{(V_s - V_L)}{I_L}$$

V_s = Supply voltage
 V_L = LED Voltage drop
 I_L = LED current

Applications that feature an alarm can be connected as above.
ALM1 must not sink more than 10mA maximum each. If supply voltage varies, use an appropriate voltage regulator.

PanelPilot Software

Lascar's PanelPilot software is available for download free of charge. Easy to install and use, the control software runs under Windows 7, 8.1 and 10. The software is used to setup the appearance and operation of the meter and then upload these settings to the meter.

Multiple types of voltmeter are supplied with the software.

The software allows the following parameters to be configured:

- Meter type
- Text labels (including units and graph labels)
- Background, graph segment and text colors
- Input scaling / calibration (at two points)
- Decimal points (entered during scaling)
- Splashscreen image selection (to display a user image, such as a logo, when the meter is powered up)



Test Equipment Depot
1-800-517-8431

99 Washington Street
Melrose, MA 02176
Phone 781-665-1400
Toll Free 1-800-517-8431

