



Scout™ SJX Series Balances

Instruction Manual



**Test Equipment
Depot**
1-800-517-8431

99 Washington Street
Melrose, MA 02176
Phone 781-665-1400
Toll Free 1-800-517-8431

 Visit us at www.TestEquipmentDepot.com

1. INTRODUCTION

This manual contains installation, operation and maintenance instructions for the Scout SJX and SJX/E Series Balances. Please read the manual completely before using the balance.

1.1 Definition of Signal Warnings and Symbols

Safety notes are marked with signal words and warning symbols. These show safety issues and warnings. Ignoring the safety notes may lead to personal injury, damage to the instrument, malfunctions and false results.

Signal Words

WARNING	For a hazardous situation with medium risk, possibly resulting in injuries or death if not avoided.
CAUTION	For a hazardous situation with low risk, resulting in damage to the device or the property or in loss of data, or injuries if not avoided.
Attention	For important information about the product.
Note	For useful information about the product.

Warning Symbols



General Hazard



Electric Shock Hazard

1.2 Safety Precautions



CAUTION: Read all safety warnings before installing, making connections, or servicing this equipment. Failure to comply with these warnings could result in personal injury and/or property damage. Retain all instructions for future reference.

- Verify that the local AC power supply is within the input voltage range printed on the AC adapter's data label.
- Only connect the AC adapter to a compatible grounded electrical outlet.
- Do not position the scale such that it is difficult to disconnect the AC adapter from the power receptacle.
- Make sure that the power cord does not pose a potential obstacle or tripping hazard.
- This equipment is intended for indoor use and should only be operated in dry locations.
- Operate the equipment only under ambient conditions specified in the user instructions.
- Do not operate the equipment in hazardous or unstable environments.
- Do not drop loads on the pan.
- Only use approved accessories and peripherals.
- Disconnect power from the equipment before cleaning or servicing.
- Service should only be performed by authorized personnel.

2. INSTALLATION

2.1 Installing Components

Refer to the illustrations and instructions below to identify and assemble your Scout balance with its components. All components must be assembled before using the balance.

2.1.1 Releasing the Transportation Lock

Release the red transportation lock by turning the red pointer 90 degrees counter-clockwise to unlock.

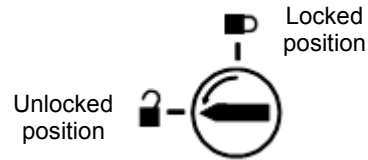

Figure 2-1. Transportation Lock

Note:

For SJXN models, the shipping lock needs to be removed (by pulling it out) before installing the pan.

2.1.2 Installing the Weighing Pan

For SJX/E

Balances with a rectangular pan are placed into the sub-platform as shown and rotated counter-clockwise until it locks. Round pans are placed straight down on sub-pan.

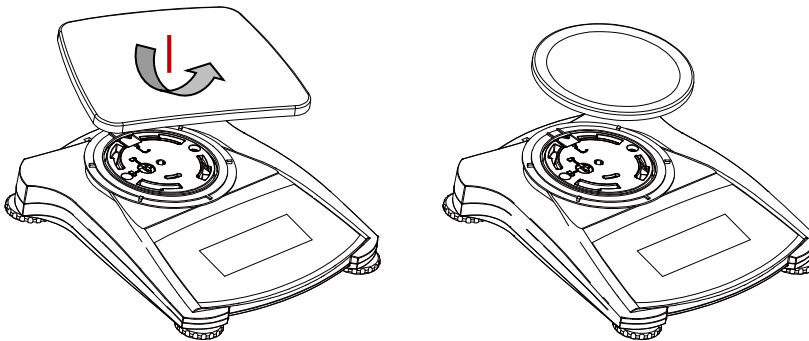

Figure 2-2. Pan Installation (for SJX/E)

For SJX

Install the stainless steel pan directly on the subplatform.

2.1.3 Security Slot

A security slot is provided at the rear of the balance allowing the balance to be secured by an optional cable and lock accessory.

2.2 Selecting the Location

For best performance, the Scout balance should be used in a clean, stable environment. Do not use the balance in environments with excessive drafts, with rapid temperature changes, near magnetic fields or near equipment that generates magnetic fields, or vibrations.

2.3 Leveling the Balance

The Scout has an illuminated level indicator as a reminder that the balance should be leveled for accurate weighing. There is a level bubble in a small round window on the front of the Balance. To level the balance, adjust the feet at each corner until the bubble is centered in the circle. Be sure the equipment is level each time its location is changed.

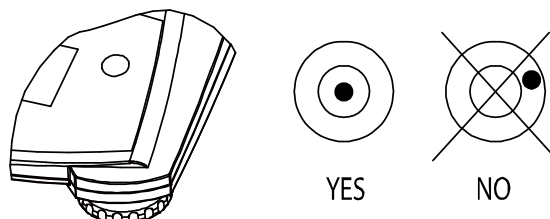

Figure 2-3. Level indicator

2.4 Connecting Power

AC Adapter Installation

AC power is used to power the scale when battery power is not needed. First, connect the AC Adapter (supplied) to the AC Adapter Input Jack at the rear of the balance then connect the AC plug to an electrical outlet.

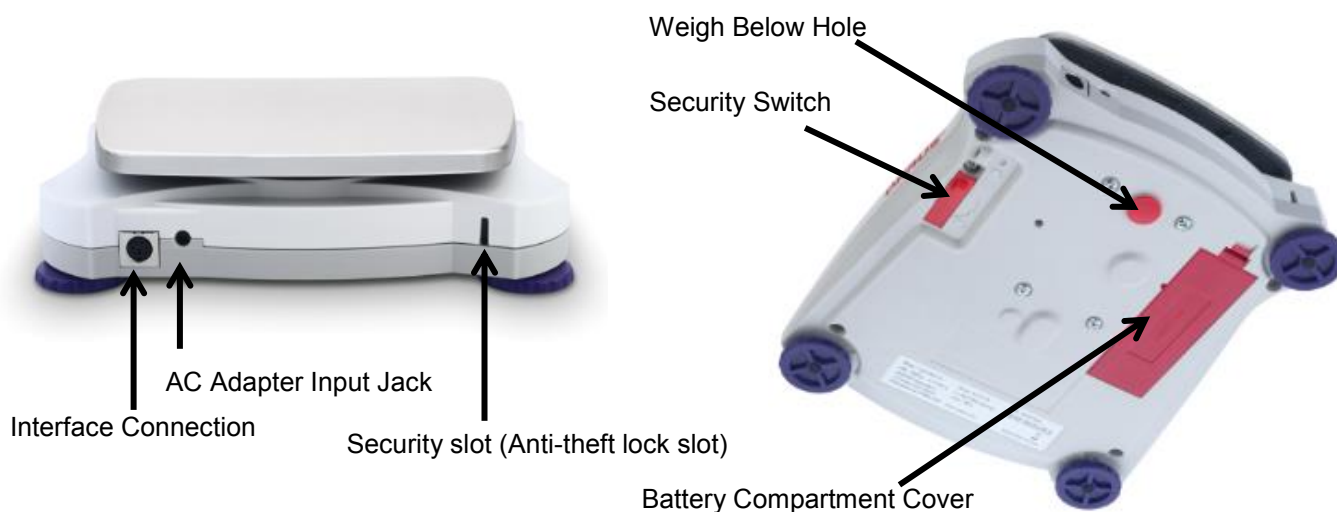

Figure 2-4. Rear and bottom view of balance

Battery Installation

Install the four “AA” batteries with polarity as shown in the battery compartment.

Note:

After power on, it is recommended to let the balance warm for at least 5 minutes before using it.

2.5 Initial Calibration

When the Balance is first installed, and when it is moved to another location, it must be calibrated to ensure accurate weighing results.

For SJX/E models, the balances must be calibrated by using the external calibration weights. For SJX models, the balances have built in internal calibration system which can calibrate the balance without the need for external calibration masses. Alternately, the SJX balances can be manually calibrated with external masses.

Have the appropriate calibration masses available before beginning calibration. Refer to the Calibration Section for masses and calibration procedure.

3. OPERATION

3.1 Controls

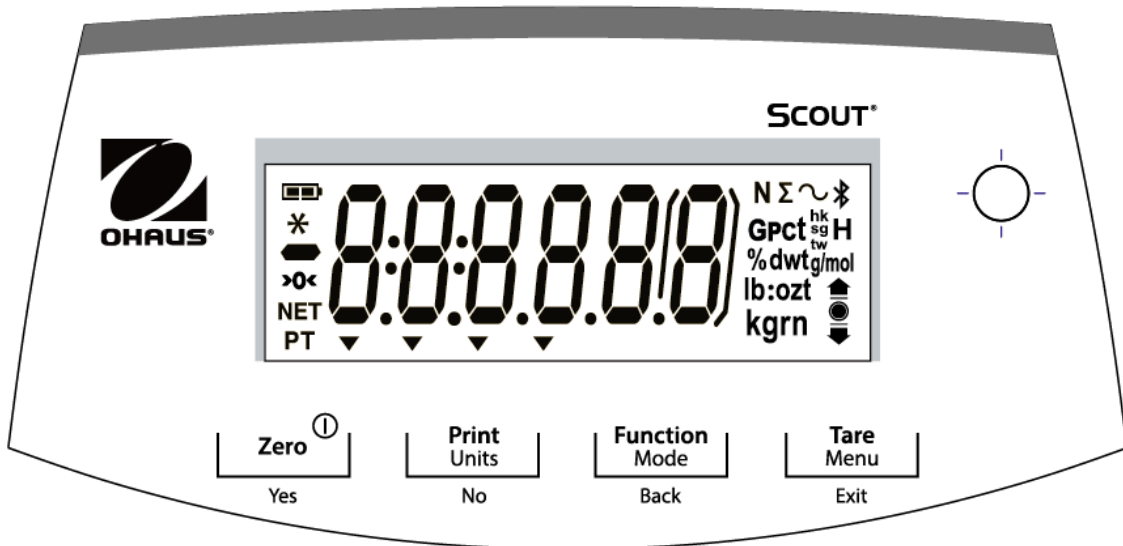

Figure 3-1. Scout Control Panel

TABLE 3-1. Button Functions

Button	Zero ^① Yes	Print Units No	Function Mode Back	Tare Menu Exit
Primary Function (Short Press)	Zero/On Turns the balance on If balance is On, sets Zero	Print Sends the current value to the selected COM ports if AUTOPRINT is set to Off.	Function Initiates an application mode.	Tare Enter/clear a tare value.
Secondary Function (Long Press) (Extended Press)	Zero/Off Turns the balance Off. None	Units Changes the weighing unit. None	Mode Allows changing the application mode. None	Menu Enter the User menu. View the preset Tare value
Menu Function (Short Press)	Yes Accepts the current setting on the display.	No Advances to the next menu or menu item. Rejects the current setting on the display and advances to the next available setting.	Back Moves Back to previous menu item.	Exit Exits the User menu. Aborts the calibration in progress.

- Notes:**
- ¹ Short Press: Press less than 1 second.
 - ² Long Press: Press and hold for more than 2 seconds.
 - ³ Extended Press: Press and hold for more than 5 seconds.

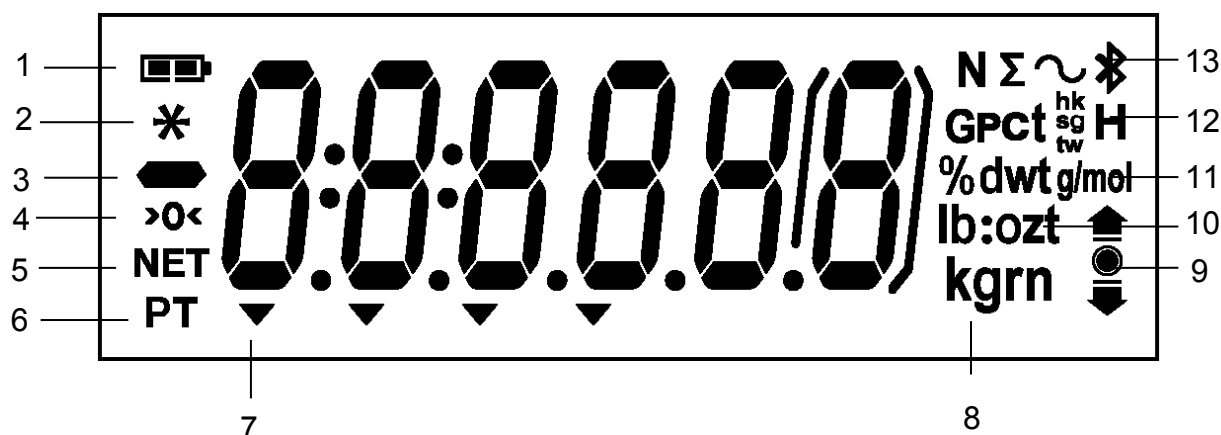

Figure 3-2. Scout Display

TABLE 3-2. Display Symbols

Item	Description	Item	Description
1	Battery charge symbol	8	Kilogram, grain symbols
2	Stable weight symbol	9	Check Weighing symbols
3	Negative symbol	10	Pound, Ounce, Pound:Ounce symbols
4	Center of Zero symbol	11	Percent, dwt, g/mol symbols
5	NET symbol	12	G (Gravity), Pieces, t hk, t sg, t tw, H (Hold) symbols
6	Preset Tare symbol	13	Newton, Totalization, Dynamic, Bluetooth symbols
7	Pointer symbols		Point

3.2 Turning Balance On/Off

To turn the balance on, press and hold the **On/Zero Off** button for 1 second. The balance performs a display test, momentarily displays the software version, and then enters the active weighing mode.

To turn the balance off, press and hold the **On/Zero Off** button until OFF is displayed.

3.3 Calibration Operation

When the balance is operated for the first time, a span calibration is recommended to ensure accurate weighing results. Before performing the calibration, be sure to have the appropriate calibration weights. Ensure that the Security switch is set to unlocked position.

SJX/E:

Press and hold **Menu** until [MENU] (Menu) is displayed. When the button is released, the display will show [C.R.L.]. Press **Yes** to accept. [SPAN] will then be shown. Press **Yes** to begin the span calibration.

[--E--] will be displayed while zero reading is stored. Next, the display shows the calibration weight value. Press the **No** key toggle the value. Place the specified calibration mass on the pan. [--E--] will be displayed while the reading is stored. The display will show [done] if the calibration was successful. The balance returns to the previous application mode and is ready for use.

SJX (Internal Calibration Mode):

Press and hold **Menu** until [MENU] (Menu) is displayed. Release the button, the display will show [CAL]. Press **Yes** to accept. [In.CAL] will then be shown. Press **Yes** to begin the Internal calibration. The zero reading is stored automatically. Pull the InCal handle while the display show [PULL]. Push the InCal handle while the display show [PUSH]. Repeat the Pull and Push steps one more time. The display will show [done] if the calibration was successful. The balance returns to the previous application mode and is ready for use.



3.4 Weighing Mode

This mode is the factory default setting.

1. If needed, press and hold **Mode** until [WEIGH] (Weigh) is displayed.
2. If required, place an empty container on the pan and press **Tare**.
3. Add sample to the pan or container. The display shows the weight of the sample.

3.5 Counting Mode

This mode counts large numbers of items based on the weight of a reference count.

1. If required, place an empty container on the pan and press **Tare**.
2. Press and hold **Mode** until [Count] (Count) is displayed. [CLR.PW] (Clear Average Piece Weight, APW) will then display.
If no APW exists, the balance will display [PUL. 0], proceed to step 5.
3. Press **No** to use the stored APW. Proceed to step 7.
4. Press **Yes** to establish an APW.
5. The balance will then display the sample size, i.e. [PUL. 0]. Press **No** or **Back** to toggle the choices (5, 10, 20, 50 or 100).
6. Put the indicated number of pieces on the pan then press **Yes** to calculate the APW. The display shows the piece count.
7. Add additional pieces until the desired count is reached.
8. To clear the stored APW press and hold **Mode** until [Count] is displayed. Press **Yes** when [CLR.PW] is displayed.

Note: Press **Function** to view the current APW.

3.6 Percent Mode

This mode measures the weight of a sample as a percentage of a reference weight.

1. If required, place an empty container on the pan and press **Tare**.
2. Press and hold **Mode** until [PERCENT] is displayed. [CLR.REF] (clear reference) will then display. If no reference weight exists, the balance will display [PUL.REF], proceed to step 5.
3. Press **No** to use the stored reference weight and proceed to step 6.
4. Press **Yes** to establish a new reference. Balance will now display [PUL.REF].
5. Add the desired reference material to the pan or container. Press **Yes** to store the reference weight. The display shows 100%.
6. Replace the reference material with the sample material. The display shows the percentage of the sample compared to reference weight.
7. To clear the stored reference press and hold **Mode** until [PERCENT] is displayed. Press **Yes** when [CLR.REF] is displayed.

Note: Press **Function** to view the current reference weight.



3.7 Check Mode

Use this mode to compare the Weight to a target weight range. The balance supports positive, negative and zero check weighing.

3.6.1 Check Weighing

Use this mode to compare the weight of items to a target weight range.

1. Press and hold **Mode** until [**CHECK**] (Check) is displayed. [**CLRF**] (clear check limits) will then display.
2. Press **No** to use the stored check limits and proceed to step 5.
3. Press **Yes** to establish new check limits. The balance will then display [**Set. Lo**]. Press **Yes** to view the “Low” limit value. Press **Yes** to accept or **No** to edit the “Low” limit value. The stored value then displays with the first digit highlighted [**000.000** kg]. Repeatedly press **No** until the desired number appears. Press **Yes** to accept and highlight the next digit. Repeat until all the digits are correct. Press **Yes** to accept the “low” limit value, [**Set. Hi**] will be displayed.
4. Repeat the same procedure to accept or edit the “high” value.
5. If required, place an empty container on the pan and press **Tare**.
6. Place sample material on the pan or in the container. If the sample weight is under the target weight range, the under icon  will light.

If the sample is within the target weight range, the accept symbol  will light. If the sample is over the target weight range, over icon  will light.

Note: Press **Function** to view the low and high check limits.

Positive Check

Positive check is used to determine when the material added to the balance is within the target range. In this case the UNDER and OVER limits must be positive values. (The OVER limit must be greater than the UNDER limit.)

Add material to the balance until it is within the ACCEPT () range.

Negative Check

Negative check is used to determine when the material removed from the balance is within the target range. In this case the UNDER and OVER limits are both negative values. (The UNDER limit must be greater than the OVER limit.)

Place the item to be weighed on the balance and press **TARE**.

Remove a portion of the item until it is within the ACCEPT range.

Zero Check

Zero check is used when comparing subsequent samples to an initial reference sample. In this case, the UNDER limit must be a negative value and the OVER limit must be a positive value. Place the reference item on the balance and press **TARE**. Remove the reference sample and place the item to be compared on the balance to determine if it is within the ACCEPT range.

3.8 Totalize Mode

This mode allows the user to store a series of weight measurements. Totalize mode has been initiated when the symbol “Σ” is displayed and the current unit is displayed.

Notes: Only positive numbers are totalized.

1. Press and hold **Mode** until [Totalize] (Totalization) is displayed. [Clear] will then be displayed.
2. Press **Yes** or **No** key to clear the current totalized data or not. When a weight is added to the scale the value is displayed.
3. If required, place an empty container on the pan and press **Tare**. Add the first item, its weight is displayed.
Press **Function** to store the weight, the “Σ” symbol will flash and the display will show the total weight.
4. Press **Tare** (or remove the weight in previous operation) and add the next item. The scale will display its weight.
Press **Function** to store its weight. The “Σ” symbol will flash and the new total weight will be displayed.
5. Repeat step 4 for all of the items to be accumulated.
6. To clear the stored total press and hold **Mode** until [Totalize] is displayed. When [Clear] is displayed, press **Yes**.

3.9 Density Mode

This mode allows the user to calculate the specific gravity of a sample when using the density kit. Density mode has been initiated when “G” and the current unit is displayed.

The sample is weighed in air suspended from the hook and then weighed in water. The formula is

$$\frac{\text{dry weight}}{\text{dry weight} - \text{wet weight}}$$

Preparation

Prepare the balance as shown below. Remove the balance pan, insert the hook and install the beaker stand (beaker is not supplied). Then press the **Zero/On** button to turn the balance on.

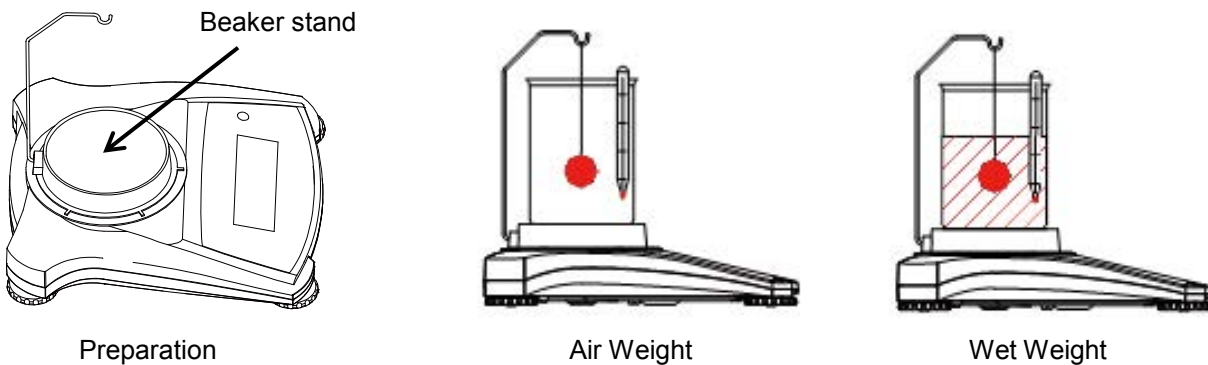

Figure 3-3. Density Setup

Density setup

1. Press and hold **Mode** until [SPEC.Gr] is displayed. [Air Weigh] will then be displayed.
2. Place the sample on the hook as described above and press **Yes** to store the dry weight value. [Wet Weigh] will then be displayed.
3. Suspend the sample in water and press **Yes** to store the wet weight value. The specific gravity value is now displayed and “G” is blinking while the unit icon is turned off.

Notes: Specific Gravity has no unit of measure.

For large samples it is recommended to use the weighing below feature instead of the hook.

3.10 Hold Mode

There are two modes for the display hold:

- Peak Hold: allows the user to capture and store the highest stable weight value ($\geq 5d$).
- Display Hold (default): allows the user to capture and store the first stable weight value ($\geq 5d$).

Start

If no weight value is held on the display, press **Function** key to begin. The [**rEAAdy**] (Ready) will be displayed until a weight is added on the pan.

When the stable value is being held on the display, the Hold icon (**H**) will blink and the displayed weight will not change.

Reset

If the pan is empty and a weight value was held on the display, a single short press of the **Function** key will clear the held value and show the new weight on the pan.

1. Press and hold **Mode** until [**HoLd**] is displayed.
2. If required, place an empty container on the pan and press **Tare**. Zero value will then display.
3. Press **Function** key to begin. The [**rEAAdy**] (Ready) will be displayed.
4. Place samples to be weighed on the pan.
5. The stable value will be held on the display, the Hold icon (**H**) will blink.





4. MENU SETTINGS

The User Menu allows the customizing of balance settings.

Note: Additional Sub-Menus may be available if Interface Options are installed. See Interface User Manual for the additional setting information.

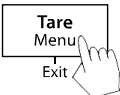
4.1 Menu Navigation

User Menu:

<u>Sub-Menus</u>	<u>C.a.l</u>	<u>S.E.t.U.P</u>	<u>M.o.d.E</u>	<u>U.n.i.t**</u>	<u>E.n.d</u>
<i>User Menu Items:</i>	<i>In.CAL *</i>	<i>Reset</i>	<i>Reset</i>	<i>Reset</i>	
 Long press - Enter menu	<i>A.CAL *</i>	<i>Filter</i>	<i>Weighing</i>	<i>g</i>	
Yes 	<i>On/Off</i>	<i>Low/Med/High</i>	<i>On/Off</i>	<i>kg</i>	
No/Back 	<i>CAL.Adj*</i>	<i>AZT</i>	<i>Counting</i>	<i>ct</i>	
Exit 	<i>-100</i>	<i>0.5/1/3/Off</i>	<i>On/Off</i>	<i>ozt</i>	
	<i>0</i>	<i>StableRange</i>	<i>Percent</i>	<i>dwt</i>	
	<i>100</i>	<i>0.5/1/2//5</i>	<i>On/Off</i>	<i>lb</i>	
	<i>Span</i>	<i>Backlight</i>	<i>Check</i>	<i>grn</i>	
	<i>Lin</i>	<i>Off/On/Auto</i>	<i>On/Off</i>	<i>hkt</i>	
		<i>Auto Tare</i>	<i>Totalize</i>	<i>sgt</i>	
		<i>Off/On/On-acc</i>	<i>On/Off</i>	<i>twt</i>	
		<i>Auto Off</i>	<i>Density</i>	<i>t</i>	
		<i>Off/1/5/10</i>	<i>On/Off</i>	<i>tola/tical</i>	
			<i>Hold</i>		
			<i>Disp/Peak/Off</i>		
	<i>End</i>	<i>End</i>	<i>End</i>	<i>End</i>	

Note:

* These sub-menus are not available in SJX/E models.

** Available Units may vary by local regulations.

When the Security Switch is in locked position, see figure below, the menu settings are affected as follows:

- External calibration function is hidden
- The readability will be reduced by a factor of 10 or brackets will be displayed around the last digit, depending on the model
- Units are locked to the current setting
- Stable range locked to 1d
- AZT locked to 0.5d
- Zero range forced to 2%
- Filter Level is locked to current setting.
- Stable only in Print menu locked to ON
- Continuous/Interval print cannot be selected (SJX...N/E models only)

Security switch:

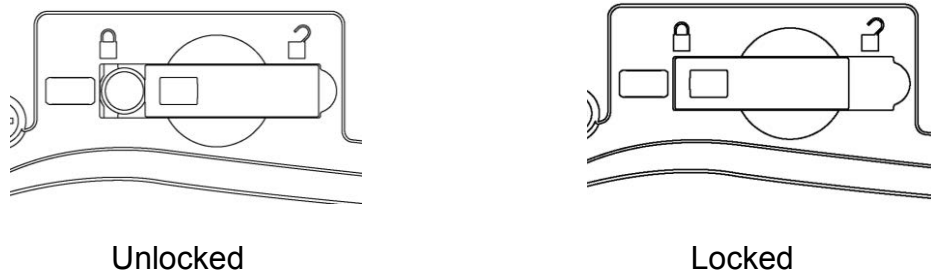

Figure 4-1. Security switch.

4.2 Calibration Menu

Enter this menu to perform calibrations.

Internal Calibration*	Perform
Automatic Calibration*	Off, On
Calibration Adjustment*	-100...0...100
Span:	Perform
Linearity:	Perform
End Calibration:	Exit menu

Notes: * These sub menus are not available in SJX/E models. The settings vary with model.

Internal Calibration [In.CAL]

Initiates an internal calibration procedure.

Automatic Calibration [A.CAL]

Initiates an automatic calibration procedure.

- OFF = disabled
- ON = enabled

Calibration Adjustment [CAL.Adj]

Set the calibration adjustment factor for the internal calibration mass.

-100...0...100

Span [SPAN]

Initiates a span calibration procedure (zero and span)

Lin [L IN]

Initiates a linearity calibration procedure (zero, mid-point and span).

End Cal [End]

Advance to the next menu or return to the top of the current menu.

4.3 Setup Menu

Enter this menu to set balance parameters.

Reset:	no, yes
Filter:	Low, Med , High
Auto Zero Tracking:	off, 0.5d , 1d, 3d
Stable:	0.5d, 1d , 2d, 5d
Backlight:	off, on, auto
Auto Tare:	off , on, on-acc
Auto Off:	off , 1, 5, 10
End Setup:	Exit menu

Note: Bold always represents factory default value.

Reset [rE5E5]

Reset the Setup menu to factory defaults.

NO = not reset
YES = reset

Filter [F .LLEr]

Set the amount of signal filtering.

LOW = less stability, faster stabilization time
MED = normal stability, stabilization time
HI = greater stability, slower stabilization time

AZT [A2E]

Set the automatic zero tracking functionality.

OFF = disabled
0.5d = the display will maintain zero until a change of 0.5 divisions per second has been exceeded.
1d = the display will maintain zero until a change of 1 divisions per second has been exceeded.
3d = the display will maintain zero until a change of 3 divisions per second has been exceeded.

Stable Range [5LEBLE]

Set the amount the reading can vary while the stability symbol remains on.

0.5d = 0.5 balance division
1d = 1 balance division
2d = 2 balance division
5d = 5 balance division

Back Light [b.L .9hE]

Sets backlight functionality.

OFF = always off
ON = always on
AUTO = turns on when a button is pressed or the displayed weight changes.

Note: When connected with power pack, the backlight is always on.

Auto Tare [A.EArE]

Set the automatic tare functionality.

OFF = Automatic Tare is disabled
ON = the first stable gross weight is tared
ON-ACC = stable gross loads within the accept limits are tared (in Check weighing mode)

Auto off [A.OFF]

Set the automatic shut off functionality.

- OFF = disabled
- 1 = powers off after 1 minute of no activity
- 5 = powers off after 5 minutes of no activity
- 10 = powers off after 10 minutes of no activity

End Setup [End]

Advance to the next menu or return to the top of the current menu.

4.4 Mode Menu

This menu activates modes so they will be available for use with the Mode button.

Reset:	no, yes
Weigh:	off, on
Count:	off, on
Percent:	off, on
Check:	off, on
Totalization:	off, on
Density:	off, on
Hold:	Disp, Peak, Off
End Mode:	Exit menu

Reset [rESEt]

Reset the Mode menu to factory defaults.

- NO = not reset
- YES = reset

Weigh [WEIGH]

Set the status.

- OFF = disabled
- ON = enabled

Count [Count]

Set the status.

- OFF = disabled
- ON = enabled

Percent [PERcent]

Set the status.

- OFF = disabled
- ON = enabled

Check [CHECK]

Set the status.

- OFF = disabled
- ON = enabled

Totalization [tOTAL]

Set the status.

- OFF = disabled
- ON = enabled

Density [SPEC.Gr]

Set the status.

OFF = disabled

ON = enabled

Hold [HoLd]

Set the sub-mode.

OFF = disabled

Peak Hold = allows the user to capture and store the highest stable weight value (>=5d).

Display Hold = allows the user to capture and store the first stable weight value (>=5d).

When the stable value is being held on the display, the “Hold” icon will blink and the displayed weight will not change.

Advance to the next menu or return to the top of the current menu.

End Mode [End]**4.5 Unit Menu**

This menu activates units so they will be accessible with the **Units** button. The units in the menu must be turned “on” to be active.

Note: Available units vary by model and local regulations.

g:	off, on
kg:	off , on
ct:	off, on
oz:	off , on
ozt:	off , on
dwt:	off , on
lb:	off , on
grn:	off , on
hkt:	off , on
sgt:	off , on
twt:	off , on
t:	off , tola, tical
End Unit:	Exit menu

4.6 Additional Features

Weigh Below Hook

The Scout Balance is equipped with a weigh below hook for weighing below the balance. The weigh below hook on SJX/E models is located at the reverse side of the battery cover as shown below (on SJX models it is located in the subplatform). To use this feature, remove the red protective cover underneath for the weigh below opening.

Attention: Before turning the balance over, remove the Pan and Pan Support (if present) and then set the transportation lock to “locked” position.

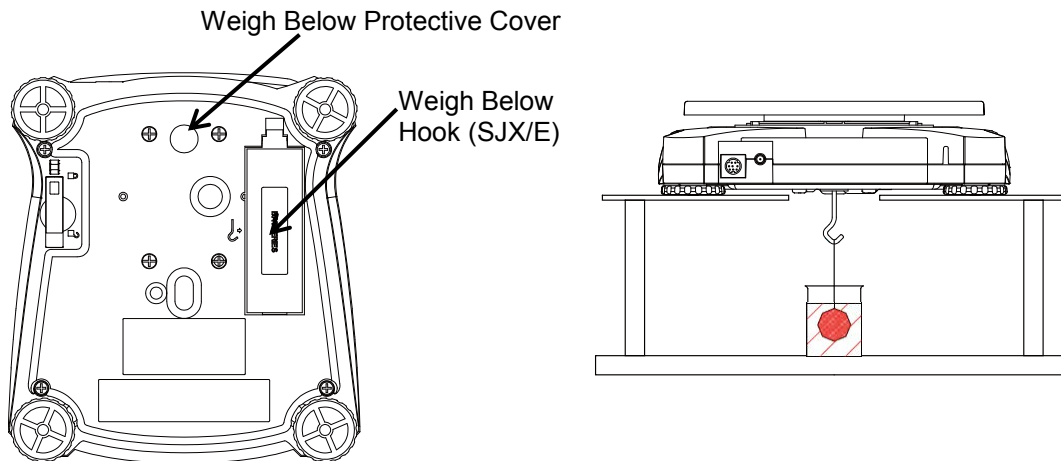

Figure 4-2. Weigh below

The balance can be supported using lab jacks or any other convenient method. Ensure the balance is level and secure and that the transportation lock has been released. Power on the Balance, then use a string or wire to attach items to be weighed.

Connecting the Interface

Use an optional interface connectivity kit to connect the balance either to a computer, printer or OHAUS auxiliary display.

Below Interface kit accessories are available:

RS232, USB Host, USB Device, Ethernet, Bluetooth®.

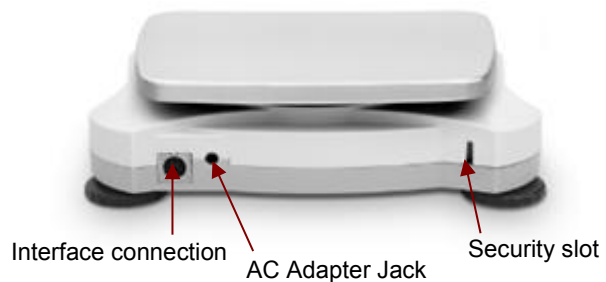

Figure 4-3. Rear of the balance

* Interface kits may vary according to local regulations

The Bluetooth® word mark and logos are registered trademarks owned by Bluetooth SIG, Inc. and any use of such marks by OHAUS is under license.

5. MAINTENANCE

5.1 Cleaning



WARNING: Electric Shock Hazard. Disconnect the equipment from the power supply before cleaning.

The housing may be cleaned with a cloth dampened with a mild detergent if necessary.



Attention: Do not use solvents, chemicals, alcohol, ammonia or abrasives to clean the housing or control panel.

5.2 Troubleshooting

The following table lists common problems and possible causes and remedies. If the problem persists, contact OHAUS or your authorized dealer.

TABLE 5-1

Symptom	Possible Cause
Cannot turn on	No power to balance
Poor accuracy	Improper calibration Unstable environment
Cannot calibrate	Security switch in locked position
Err B.1	Weight exceeds power on zero range.
Err B.2	Weight below power on zero range.
Err B.3	Over load (weight exceeds rated capacity)
Err B.4	Under load (pan removed)
Err B.5	Tare out of range
Err B.6	Displayed value exceeds 999999 (possible in Totalization mode)
Err B.7	Unknown internal weight position
rEF.Err	Parts counting or percentage error – sample weight <1d. Balance shows error then exits parts counting or goes to [CLr.APU].
Lo.rEF	Percent Reference weight or APW is too low for accurate results
CAL E	Fail to do calibration.
USb.Err	Cannot find menu or app file in U-disk.

5.3 Service Information

If the troubleshooting section does not resolve or describe your problem, contact your authorized OHAUS service agent. An OHAUS product service specialist will be available to provide assistance.

5.4 Accessories

TABLE 5-2. ACCESSORIES

DESCRIPTION	Item Number	DESCRIPTION	Item Number
RS232 kit	30268982	Stacking Kit, x1	30268988
USB Host kit	30268983	Specific Gravity kit	30269020
USB Device Kit	30268984	Auxiliary Display Kit	30269019
Bluetooth Kit*	30268985	Carrying Case	30269021
Ethernet Kit	30268986	In-Use Cover	30269022
Stacking Kit, x6	30268987	Printers and Cables	Contact OHAUS

Note: * Bluetooth kit is only available in certain regions according to the local regulations.

6. LEGAL FOR TRADE

When the balance is used in trade or a legally controlled application it must be set up, verified and sealed in accordance with local weights and measures regulations. It is the responsibility of the purchaser to ensure that all pertinent legal requirements are met.

6.1 Settings

Before verification and sealing, perform the following steps in Order:

1. Verify that the menu settings meet the local weights and measures regulations.
2. Units menu should be reviewed. Verify the units turned **On** meet the local weights and measures regulations.
3. Perform a calibration as explained in Section 4.2.
3. Set the position of the Security Switch to the locked position.

6.2 Sealing

After the Balance has been verified, it must be sealed to prevent undetected access to the legally controlled settings. Before sealing the device, ensure that the security switch is in the Locked position.

If using a wire seal, pass the sealing wire through the holes in the security switch and Bottom Housing as shown.

If using a paper seal, place the seal over the security switch and Bottom Housing as shown.

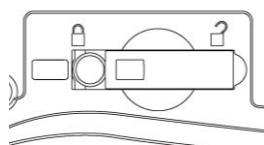

Unlocked

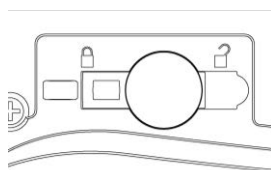

Locked with Paper Seal

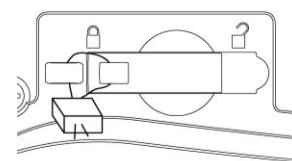

Locked with Wire Seal

7. TECHNICAL DATA

The technical data is valid under the following ambient conditions:

Indoor use only

Operating temperature range: +5 °C to +40 °C

Relative humidity: 10% to 80% at 31°C , decreasing linearly to 50% at 40°C, non-condensing

Altitude: Up to 2000 m

Power: AC power adaptor input 100-240V 50/60 Hz and output 5 V DC 1 A, or 4 AA batteries

Pollution degree: 2

Installation category: refer to the tables below

Main supply voltage fluctuations: up to ± 10% of the nominal voltage

7.1 Specifications

General Models:

Model	SJX323	/	SJX622	SJX1502	/	/	SJX6201	/
	SJX323/E	SJX322/E	SJX622/E	SJX1502/E	SJX621/E	SJX3201/E	SJX6201/E	SJX8200/E
Capacity	320 ct (64 g)	320 g	620 g	1500 g	620 g	3200 g	6200 g	8200 g
Readability	0.005 ct (0.001 g)	0.01 g	0.01 g	0.01 g	0.1 g	0.1 g	0.1 g	1 g
Repeatability (Std. Dev.)	0.002 g	0.01 g	0.01 g	0.02 g	0.1 g	0.1 g	0.1 g	1 g
Linearity	0.003 g	0.01 g	0.02 g	0.03 g	0.1 g	0.1 g	0.2 g	1 g
Span Calibration Mass*	50 g	200 g	300 g	1.5 kg	300 g	3 kg	5 kg	8 kg
Linearity Calibration Mass	30, 60 g	200, 300 g	300, 600 g	1 kg, 1.5 kg	300, 600 g	1.5 kg, 3 kg	3 kg, 6 kg	4 kg, 8 kg
Capacity x Readability (kg)	/	/	/	1.5 x 0.00001	/	3.2 x 0.0001	6.2 x 0.0001	8.2 x 0.001
Capacity x Readability (ct)	320 x 0.005	1600 x 0.05	3100 x 0.05	7500 x 0.05	3100 x 0.5	16000 x 0.5	31000 x 0.5	41000 x 5
Capacity x Readability (oz)	2.25750 x 0.00005	11.2880 x 0.0005	21.8700 x 0.0005	52.9110 x 0.0005	21.870 x 0.005	112.880 x 0.005	218.700 x 0.005	289.25 x 0.05
Capacity x Readability (ozt)	2.05765 x 0.00005	10.2880 x 0.0005	19.9335 x 0.0005	48.2260 x 0.0005	19.930 x 0.005	102.880 x 0.005	199.335 x 0.005	263.60 x 0.05
Capacity x Readability (dwt)	41.153 x 0.001	205.76 x 0.01	398.67 x 0.01	964.52 x 0.01	398.7 x 0.1	2057.6 x 0.1	3986.7 x 0.1	5270 x 1
Capacity x Readability (lb)	/	/	1.36690 x 0.00005	3.30690 x 0.00005	1.3670 x 0.00005	7.0550 x 0.00005	13.6685 x 0.00005	18.080 x 0.005
Capacity x Readability (grm)	987.66 x 0.02	4938.4 x 0.2	9568.0 x 0.2	23148.4 x 0.2	9570 x 2	49380 x 2	95680 x 2	126540 x 20
Stabilization Time (s)	1.5	1	1	1.5	1	1	1	1
Construction	ABS plastic housing with 304 stainless steel (SST) pan							
Draftshield	Yes	No						
Calibration	SJX/E: User-selectable external span or linearity calibration SJX: Manual Internal Calibration / User-selectable external span or linearity calibration							
Tare Range	Full Capacity by subtraction							
Weighing Units**	g, kg, ct, oz, ozt, dwt, lb, gm, hkt, sgt, twt, tical, tola							
Application Modes**	Weighing, Parts Counting, Percent Weighing, Check Weighing, Totalization, Density Determination, Display Hold							
Typical Battery Life	80 hours			120 hours		80 hours		120 hours
Specified Temperature Range	10°C (50°F) to 40°C (104°F) at 10% to 80% relative humidity, non-condensing							
Storage Conditions	-20°C (-4°F) to 55°C (131°F) at 10% to 90% relative humidity, non-condensing							
Communication	RS232, USB Host, USB Device, Ethernet or Bluetooth*** (all available as accessory)							
Display Type	Backlit LCD: 6-digit 7-segment with white LED backlight							
Display Size	20 mm digits / 0.78 in							
Pan Size (W x D)	Ø93 mm / 3.7 in	Ø120 mm / 4.7 in		170 x 140 mm / 6.7 x 5.5 in				
Scale Dimensions - SJX/E (W x D x H)	202 x 222 x 103 mm / 8 x 8.7 x 4.1 in	202 x 224 x 54 mm / 8 x 8.8 x 2.1 in						
Scale Dimensions - SJX (W x D x H)	202 x 230 x 114 mm	202 x 230 x 68 mm						
Shipping Dimensions - SJX/E (W x D x H)	300 x 250 x 129mm / 11.8 x 9.8 x 5.1 in	300 x 250 x 86 mm / 11.8 x 9.8 x 3.4 in						
Shipping Dimensions - SJX (W x D x H)	300 x 250 x 129mm							
Net Weight (SJX/E)	1 kg / 2.2 lb							
Net Weight (SJX)	1.1 kg							1.6 kg
Shipping Weight (SJX/E)	1.5 kg / 3.3 lb							
Shipping Weight (SJX)	1.7 kg							2.2 kg

Notes:

* Span calibration weight and scoop are included with 64g model

** Available Weighing Units and Application Modes vary by local regulations.

*** Bluetooth kit is only available in certain regions according to the local regulations

EC Type Approved Models:

Model	SJX323M	SJX622M	SJX1502M	SJX6201M
Capacity	320 ct (64 g)	620 g	1500 g	6200 g
Readability	0.01 ct (0.001 g)	0.01 g	0.01 g	0.1 g
Verification Interval e	0.1 ct (0.01 g)	0.1 g	0.1 g	1 g
Class	II			
Repeatability (Std. Dev.)	0.002 g	0.01 g	0.02 g	0.1 g
Linearity	0.003 g	0.02 g	0.03 g	0.2 g
Span Calibration Mass*	50 g	300 g	1.5 kg	5 kg
Linearity Calibration Mass	30, 60 g	300, 600 g	1 kg, 1.5 kg	3 kg, 6 kg
Capacity x Readability (kg)	/	/	1.5 x 0.00001	6.2 x 0.0001
Capacity x Readability (ct)	320 x 0.01	3100 x 0.5	7500 x 0.5	31000 x 5
Stabilization Time (s)	1.5	1	1.5	1
Construction	ABS plastic housing with 304 stainless steel (SST) pan			
Draftshield	Yes	No		
Calibration	Manual Internal Calibration			
Tare Range	Full Capacity by subtraction			
Weighing Units**	g, kg, ct			
Application Modes**	Weighing, Parts Counting, Percent Weighing, Check Weighing, Totalization, Density Determination, Display Hold			
Typical Battery Life	80 hours			
Specified Temperature Range	10°C to 30°C at 10% to 80% relative humidity, non-condensing			
Storage Conditions	-20°C to 55°C at 10% to 90% relative humidity, non-condensing			
Communication	RS232, USB Host, USB Device, Ethernet or Bluetooth*** (all available as accessory)			
Display Type	Backlit LCD: 6-digit 7-segment with white LED backlight			
Display Size	20 mm digits			
Pan Size (W x D)	Ø93 mm	Ø120 mm	170 x 140 mm	
Scale Dimensions (W x D x H)	202 x 230 x 114 mm		202 x 230 x 68 mm	
Shipping Dimensions (W x D x H)	300 x 250 x 129mm			
Net Weight	1.1 kg	1.6 kg		
Shipping Weight	1.7 kg	2.2 kg		

Notes:

* Span calibration weight and scoop are included with 64g model

** Available Weighing Units and Application Modes vary by local regulations.

*** Bluetooth kit is only available in certain regions according to the local regulations

NTEP and Measurement Canada Approved models:

Model	SJX323N/E	SJX622N/E	SJX1502N/E	SJX6201N/E
Capacity	320 ct (64 g)	620 g	1500 g	6200 g
Readability	0.01 ct (0.001 g)	0.1 g	0.01 g	1 g
Verification Interval e	0.1 ct (0.01 g)	0.1 g	0.1 g	1 g
Class	II	III	II	III
Span Calibration Mass*	50 g	300 g	1.5 kg	5 kg
Linearity Calibration Mass	30, 60 g	300, 600 g	1 kg, 1.5 kg	3 kg, 6 kg
Capacity x Readability (kg)	/	/	1.5 x 0.00001	6.2 x 0.001
Capacity x Readability (ct)	320 x 0.01	3100 x 0.5	7500 x 0.5	31000 x 5
Capacity x Readability (oz)	2.2575 x 0.0005	21.870 x 0.005	52.910 x 0.005	218.70 x 0.05
Capacity x Readability (ozt)	2.0575 x 0.0005	19.935 x 0.005	48.225 x 0.005	199.35 x 0.05
Capacity x Readability (dwt)	41.153 x 0.001	398.7 x 0.1	964.52 x 0.01	3987 x 1
Capacity x Readability (lb)	/	1.3670 x 0.0005	3.3070 x 0.0005	13.670 x 0.005
Capacity x Readability (grm)	987.6 x 0.2	9568 x 2	23148 x 2	95680 x 20
Stabilization Time (s)	1.5	1	1.5	1
Construction	ABS housing & Stainless steel pan			
Draftshield	Yes	No		
Calibration	User-selectable external span or linearity calibration			
Tare Range	Full Capacity by subtraction			
Weighing Units**	g, kg, ct, oz, ozt, dwt, lb, gm			
Application Modes**	Weighing, Parts Counting, Percent Weighing, Check Weighing, Totalization, Density Determination, Display Hold			
Typical Battery Life	80 hours			
Specified Temperature Range	Class II: 10°C (50°F) to 30°C (86°F) at 10% to 80% relative humidity, non-condensing Class III: 10°C (50°F) to 40°C (104°F) at 10% to 80% relative humidity, non-condensing			
Storage Conditions	-20°C (-4°F) to 55°C (131°F) at 10% to 90% relative humidity, non-condensing			
Communication	RS232, USB Host, USB Device, Ethernet or Bluetooth*** (all available as accessory)			
Display Type	Backlit LCD: 6-digit 7-segment with white LED backlight			
Display Size	0.78 in / 20 mm digits			
Pan Size (W x D)	Ø93 mm / 3.7 in	Ø120 mm / 4.7 in	170 x 140 mm / 6.7 x 5.5 in	
Scale Dimensions (W x D x H)	202 x 222 x 103 mm / 8 x 8.7 x 4.1 in	202 x 224 x 54 mm / 8 x 8.8 x 2.1 in		
Shipping Dimensions (W x D x H)	300 x 250 x 129mm / 11.8 x 9.8 x 5.1 in	300 x 250 x 86 mm / 11.8 x 9.8 x 3.4 in		
Net Weight	2.2 lb / 1 kg			
Shipping Weight	3.3 lb / 1.5 kg			

Notes:

* Span calibration weight and scoop are included with 64g model

** Available Weighing Units and Application Modes vary by local regulations.

*** Bluetooth kit is only available in certain regions according to the local regulations





7.2 Drawings

Figure 7.1 Dimensions

Model		A	B	C
SJX/E	with draftshield	202 mm / 8.0 in.	222 mm / 8.7 in.	103 mm / 4.1 in.
	w/o draftshield	202 mm / 8.0 in.	224 mm / 8.8 in.	54 mm / 2.1 in.
SJX	with draftshield	202 mm / 8.0 in.	230 mm / 9.1 in.	114 mm / 4.5 in.
	w/o draftshield	202 mm / 8.0 in.	230 mm / 9.1 in.	68 mm / 2.7 in.

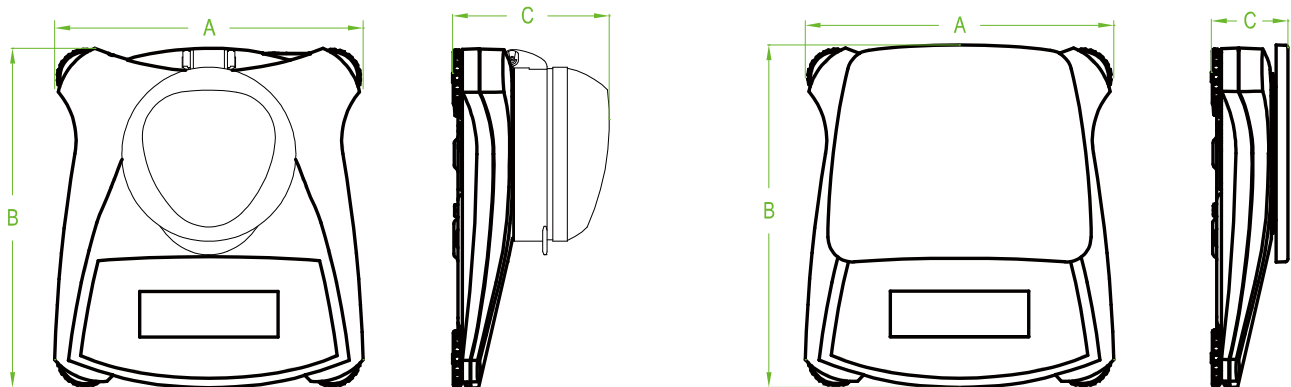
7.3 Compliance

Compliance to the following standards is indicated by the corresponding mark on the product.

Mark	Standard
	EN 61010-1, EN 61326-1 Refer to the declaration of conformity online.
	This product complies with the EU Directive 2002/96/EC (WEEE). Please dispose of this product in accordance with local regulations at the collecting point specified for electrical and electronic equipment.
	AS/NZS 61000.6.1, AS/NZS 61000.6.3
	CAN/CSA-C22.2 No. 61010-1, UL Std. No. 61010-1

	Important notice for verified weighing instruments Weighing instruments verified at the place of manufacture bear one of the preceding marks on the packing label and the green 'M' (metrology) sticker on the descriptive plate. They may be put into service immediately.
	Weighing instruments to be verified in two stages have no green 'M' (metrology) on the descriptive plate and bear one of the preceding identification marks on the packing label. The second stage of the initial verification must be carried out by the approved service organization of the authorized representative within the EC or by the national weights and measures (W+M) authorities. The first stage of the initial verification has been carried out at the manufacturer's work. It comprises all tests according to the adopted European standard EN45501:1992, paragraph 8.2.2. If national regulations limit the validity period of the verification, the user of the weighing instrument must strictly observe the re-verification period and inform the respective W+M authorities.

Disposal

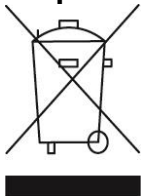

In conformance with the European Directive 2002/96/EC on Waste Electrical and Electronic Equipment (WEEE) this device may not be disposed of in domestic waste. This also applies to countries outside the EU, per their specific requirements.

Please dispose of this product in accordance with local regulations at the collecting point specified for electrical and electronic equipment. If you have any questions, please contact the responsible authority or the distributor from which you purchased this device.

Should this device be passed on to other parties (for private or professional use), the content of this regulation must also be related.

Thank you for your contribution to environmental protection.

FCC Note

This equipment has been tested and found to comply with the limits for a Class B digital device, pursuant to Part 15 of the FCC Rules. These limits are designed to provide reasonable protection against harmful interference in a residential installation. This equipment generates, uses and can radiate radio frequency energy and, if not installed and used in accordance with the instructions, may cause harmful interference to radio communications. However, there is no guarantee that interference will not occur in a particular installation. If this equipment does cause harmful interference to radio or television reception, which can be determined by turning the equipment off and on, the user is encouraged to try to correct the interference by one or more of the following measures:

- Reorient or relocate the receiving antenna.
- Increase the separation between the equipment and receiver.
- Connect the equipment into an outlet on a circuit different from that to which the receiver is connected.
- Consult the dealer or an experienced radio/TV technician for help.

Industry Canada Note

This Class B digital apparatus complies with Canadian ICES-003.

ISO 9001 Registration

In 1994, OHAUS Corporation, USA, was awarded a certificate of registration to ISO 9001 by Bureau Veritas Quality International (BVQI), confirming that the OHAUS quality management system is compliant with the ISO 9001 standard's requirements. On June 21, 2012, OHAUS Corporation, USA, was re-registered to the ISO 9001:2008 standard.

LIMITED WARRANTY

OHAUS products are warranted against defects in materials and workmanship from the date of delivery through the duration of the warranty period. During the warranty period OHAUS will repair, or, at its option, replace any component(s) that proves to be defective at no charge, provided that the product is returned, freight prepaid, to OHAUS. This warranty does not apply if the product has been damaged by accident or misuse, exposed to radioactive or corrosive materials, has foreign material penetrating to the inside of the product, or as a result of service or modification by other than OHAUS. In lieu of a properly returned warranty registration card, the warranty period shall begin on the date of shipment to the authorized dealer. No other express or implied warranty is given by OHAUS Corporation. OHAUS Corporation shall not be liable for any consequential damages.

As warranty legislation differs from state to state and country to country, please contact OHAUS or your local OHAUS dealer for further details.