

# SW1001

# SW1002

# HIOKI

Test Equipment  
Depot  
1-800-517-8431

99 Washington Street  
Melrose, MA 02176  
Phone 781-665-1400  
Toll Free 1-800-517-8431

Visit us at [www.TestEquipmentDepot.com](http://www.TestEquipmentDepot.com)

## Instruction Manual

# SWITCH MAINFRAME

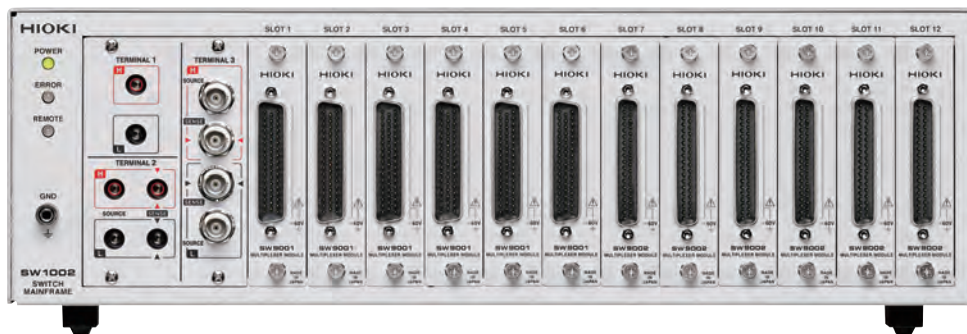

Be sure to read this manual  
before using the device

Safety Information

▶ p. 4



When using the device for the  
first time

Part Names and Functions ▶ p. 8

Measurement Flowchart ▶ p. 12

Preparation for Measurements ▶ p. 13



Troubleshooting

Troubleshooting ▶ p. 125

Error display and troubleshooting ▶ p. 126

# EN

# Contents

|                                  |   |
|----------------------------------|---|
| Introduction.....                | 1 |
| Confirming Package Contents..... | 2 |
| Safety Information .....         | 4 |
| Usage Notes.....                 | 4 |

## 1 Overview 7

|                                     |    |
|-------------------------------------|----|
| 1.1 Overview of Product.....        | 7  |
| 1.2 Features.....                   | 7  |
| 1.3 Parts Names and Functions ..... | 8  |
| 1.4 Block Diagram.....              | 10 |
| 1.5 Glossary.....                   | 11 |
| 1.6 Measurement Flowchart.....      | 12 |

## 2 Preparation for Measurements 13

|  |    |
|--|----|
| 2.1 Connecting Instruments and Controlling the Device..... | 13 |
| 2.2 Installing the Module .....                            | 15 |
| 2.3 Removing the Module.....                               | 16 |
| 2.4 Connecting the Measurement Cable.....                  | 18 |
| 2.5 Connecting the Connection Cable .....                  | 19 |
| TERMINAL 1 .....   | 20 |
| TERMINAL 2 .....   | 20 |
| TERMINAL 3 .....   | 21 |
| 2.6 Setting the Communication Setting Mode .....           | 22 |
| 2.7 Connecting the Power Cord.....                         | 23 |
| 2.8 Turning on/off the Power .....                         | 23 |
| 2.9 When the Power is Turned on .....                      | 24 |

## 3 Channel Switching 25

|   |    |
|---|----|
| 3.1 Inspection before Measurement.....            | 25 |
| Inspecting the device and peripheral devices..... | 25 |
| Checking for relay contact welding .....          | 26 |
| 3.2 Overview of Channel Switching.....            | 27 |
| 3.3 Procedure for Switching the Channel.....      | 28 |
| Selecting the connection method.....              | 28 |
| Switching the shield .....                        | 29 |
| Selecting the channel.....                        | 30 |
| 3.4 Channel Switching Operation .....             | 31 |
| 3.5 Measurement between Two Instruments.....      | 32 |
| 3.6 Precautions for Measurement .....             | 35 |
| 3.7 Channel Delay Function .....                  | 37 |

## 4 Scan Function 39

|  |    |
|--|----|
| 4.1 Overview of the Scan Function .....                | 39 |
| 4.2 Setting the Scan Channel .....                     | 40 |
| 4.3 Setting the Trigger Source for Scan Operation..... | 40 |
| 4.4 Scan Operation.....                                | 41 |
| 4.5 Resetting Scan Operation .....                     | 42 |
| 4.6 Scan Measurement Example .....                     | 43 |

## 5 Other Functions 45

|                                     |    |
|-------------------------------------|----|
| 5.1 Checking the Device Status..... | 45 |
|-------------------------------------|----|

## 6 Initialization 47

|                                   |    |
|-----------------------------------|----|
| 6.1 Initialization Settings ..... | 47 |
|-----------------------------------|----|

## 7 External Control (EXT. I/O) 49

|   |    |
|---|----|
| 7.1 External Control Flow .....   | 49 |
| 7.2 Switching between Sinking Current (NPN) and Sourcing Current (PNP)..... | 50 |
| 7.3 Connection .....  | 51 |
| Device connector and compatible connectors.....                             | 51 |
| Signal Functions .....  | 52 |
| Connection to the instrument.....   | 52 |
| 7.4 Timing Chart.....   | 53 |
| Channel switching operation and scan operation reset.....                   | 53 |
| 7.5 Internal Circuit Configuration .....                                    | 55 |
| Electrical specification .....  | 56 |
| Connection examples .....   | 57 |

## 8 Communication Function 59

|  |    |
|--|----|
| 8.1 Interface Overview and Features .....        | 59 |
| 8.2 Setting the Communication Setting Mode ..... | 59 |
| 8.3 LAN Interface .....                          | 60 |
| Communication condition settings .....           | 61 |
| Setting LAN communications .....                 | 62 |
| Connecting the LAN cable.....                    | 63 |
| 8.4 USB Interface.....                           | 64 |
| Installing the USB driver.....                   | 64 |
| Connecting the USB cable .....                   | 65 |

|      |  |     |
|------|--|-----|
| 8.5  | RS-232C Interface.....                       | 66  |
|      | Connecting the RS-232C cable .....           | 66  |
|      | Setting RS-232C communications .....         | 68  |
|      | Setting the controller (PC, PLC, etc.) ..... | 68  |
| 8.6  | Communication Command                        |     |
|      | Forwarding Function .....                    | 69  |
| 8.7  | Communication Method.....                    | 71  |
|      | Message format .....                         | 71  |
|      | Output queue and input buffer .....          | 76  |
|      | Status Byte Register .....                   | 77  |
|      | Event Registers .....                        | 79  |
|      | Initialization items .....                   | 86  |
|      | Remote state .....                           | 86  |
| 8.8  | Message List .....                           | 87  |
| 8.9  | Message Reference .....                      | 90  |
|      | Standard commands .....                      | 91  |
|      | Device-specific commands.....                | 94  |
| 8.10 | Sample Programs.....                         | 107 |
|      | Using Visual Basic® 5.0 or 6.0 .....         | 107 |
|      | Using Visual Basic® 2013 .....               | 111 |

## **9 Specification** 119

|     |                            |     |
|-----|----------------------------|-----|
| 9.1 | SW1001, SW1002 General     |     |
|     | Specification .....        | 119 |
| 9.2 | SW1001, SW1002 Input       |     |
|     | Specifications/Output      |     |
|     | Specifications/Measurement |     |
|     | Specification .....        | 120 |
|     | Basic specification .....  | 120 |
| 9.3 | SW1001, SW1002 Functional  |     |
|     | Specification .....        | 121 |
| 9.4 | SW1001, SW1002 Interface   |     |
|     | Specification .....        | 123 |
|     | LAN.....                   | 123 |
|     | USB .....                  | 123 |
|     | RS-232C .....              | 123 |
|     | EXT. I/O.....              | 124 |

## **10 Maintenance and Service** 125

|      |  |     |
|------|--|-----|
| 10.1 | Troubleshooting .....                      | 125 |
|      | Before sending the device for repair ..... | 125 |
|      | Error display and troubleshooting .....    | 126 |
| 10.2 | List of Device Error Numbers.....          | 127 |
| 10.3 | Repair and Inspection.....                 | 128 |

## **11 Multiplexer Module** 129

|      |                                      |     |
|------|--------------------------------------|-----|
| 11.1 | SW9001 Multiplexer Module            |     |
|      | (2-wire/4-wire) .....                | 129 |
|      | Features .....                       | 129 |
|      | Specification .....                  | 129 |
|      | Switching wiring diagram.....        | 132 |
|      | Connector wiring diagram .....       | 133 |
|      | Acquiring the number of relay on/off |     |
|      | cycles .....                         | 134 |
| 11.2 | SW9002 Multiplexer Module            |     |
|      | (4-terminal pair) .....              | 135 |
|      | Features .....                       | 135 |
|      | Specification .....                  | 135 |
|      | Switching wiring diagram.....        | 138 |
|      | Connector wiring diagram .....       | 139 |
|      | Acquiring the number of relay on/off |     |
|      | cycles .....                         | 140 |
| 11.3 | Accuracy Calculation Example.....    | 141 |

## **12 Appendix** 143

|      |                                      |     |
|------|--------------------------------------|-----|
| 12.1 | Measurement cable.....               | 143 |
| 12.2 | Measuring Object Short Circuit       |     |
|      | due to Relay Contact Welding .....   | 145 |
| 12.3 | Rack Mount .....                     | 147 |
|      | Rack mount bracket .....             | 148 |
|      | L-shape bracket (For installing the  |     |
|      | module in automated equipment) ..... | 151 |
| 12.4 | Outline Drawings .....               | 152 |
|      | SW1001 .....                         | 152 |
|      | SW1002 .....                         | 153 |

## **Index** 155

## **Warranty Certificat**

# Introduction

Thank you for purchasing the Hioki SW1001, SW1002 Switch Mainframe. To obtain maximum performance from the device over the long term, be sure to read this manual carefully and keep it handy for future reference.

With the optional multiplexer module (hereafter referred to as “module”) installed on this device, the input of multiple channels can be switched to one or two measuring instruments (hereafter referred to as simply “instrument”).

Modules can be installed in 3 slots for the SW1001 and 12 slots for the SW1002. Other functions are common for all the models.

Be sure to also read the separate document “Operating Precautions” before use.

## Target audience

This manual has been written for use by individuals who use the product in question or who teach others to do so. It is assumed that the reader possesses basic electrical knowledge (equivalent to that of someone who graduated from the electrical program at a technical high school).

## Trademarks

Windows, Visual Studio and Visual Basic are either registered trademarks or trademarks of Microsoft Corporation in the United States and other countries.

## Notations

|                        |  |
|------------------------|--|
| <b>*</b>               | Additional information is presented below.   |
| <b>[ ]</b>             | Menus, dialog boxes, buttons in a dialog box, and other names on the screen are indicated in brackets. |
| <b>POWER</b><br>(Bold) | Indicates the names and keys on the screen and the device in boldface.                                 |
| (p. )                  | Indicates the location of reference information.   |

## Accuracy

We define measurement tolerances in terms of f.s. (full scale), rdg. (reading), and dgt. (digit) with the following meanings.

|             |   |
|-------------|---|
| <b>f.s.</b> | (maximum display value or range)<br>The maximum display value.  |
| <b>rdg.</b> | (reading or displayed value)<br>The value currently being measured and indicated on the instrument.   |
| <b>dgt.</b> | (resolution)<br>The smallest displayable unit on a digital measuring device, i.e., the input value that causes the digital display to show a “1” as the least-significant digit |

# Confirming Package Content

## Main unit and accessories

Confirm that these contents are provided

- Model SW1001 or SW1002 Switch Mainframe

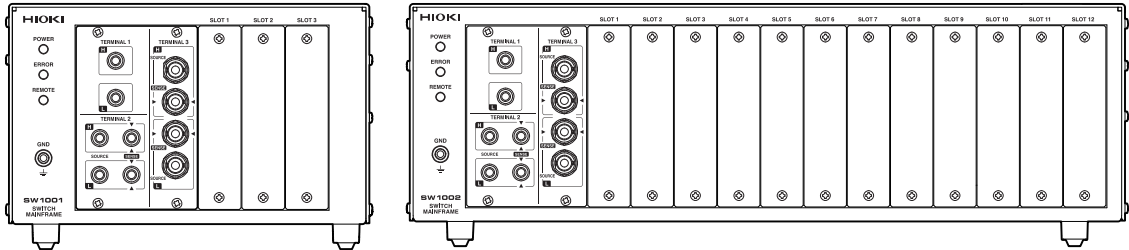

- Instruction Manual (this document)
- Power cord



- Operating Precautions (0990A905)
- CD (USB driver)\*



\* The latest version can be downloaded from our web site.

## Options

The following options are available for the device. Contact your authorized Hioki distributor or reseller when ordering.

### Module

- Model SW9001 Multiplexer Module (2-wire/4-wire)
- Model SW9002 Multiplexer Module (4-terminal pair)

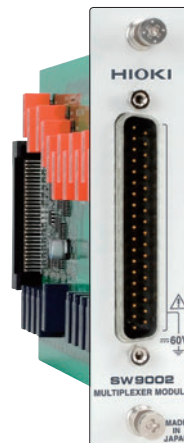
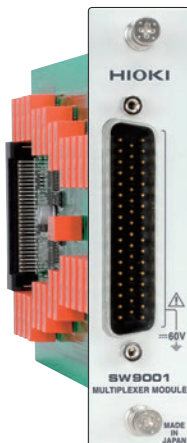

**Connection cable**

 See: "Before measurement" (p.5)

**Model L2004 Connection Cable**

Length: Approx. 910 mm  
 Maximum rated voltage: 30 V peak  
  
 Maximum rated voltage to earth: 30 V DC or less, no measurement category  
 Maximum rated current: 2.5 A peak



**Model L2108 Connection Cable**

Length: Approx. 840 mm  
 Maximum rated voltage: 60 V DC, 30 V AC rms, 42.4 V peak  
 Maximum rated voltage to earth: 60 V DC or less, no measurement category  
 Maximum rated current: 2 A peak



**Model L4930 Connection Cable Set**

Length: Approx. 1.2 m  
 Maximum rated voltage\*: CAT III: 1000 V  
 CAT IV: 600 V



\* Do not input voltage exceeding the rating of this device and the instrument.

**Communications cable**

**Model 9642 LAN Cable**



**Model L1002 USB Cable (A-B)**



**Model 9637 RS-232C Cable (9pin-9pin/1.8 m)**



## Safety Information

Be sure to also read the separate document “Operating Precautions” before use.

## Usage Notes

### Check before use

Follow these precautions to ensure safe operation and to obtain the full benefits of the various functions.

### WARNING

If a connection cable or the device is damaged, there is a risk of an electric shock. Perform the following inspection before using the device.



- Before using the device, check that the coating of the connection cables are neither ripped nor torn and that no metal parts are exposed. Using the device under such conditions could result in an electric shock. Replace any damaged cable with a new one.
- Before using the device the first time, verify that it operates normally to ensure that no damage occurred during storage or shipping. If you find any damage, contact your authorized Hioki distributor or reseller.



This device is designed to measure voltages of 60 V or lower. Do not input voltages over 60 V or measure locations exceeding 60 V from the ground potential.



If the relay of the device fails, the battery of the measuring object may be shorted (p.145).

### Installing the device and module

### CAUTION



Do not position the device on an unstable table or inclined surface. Dropping or knocking down the device can cause injury or damage to the device.

### Installing

To prevent overheating, be sure to leave the specified clearances around the device

- The device should be operated only with the bottom side downwards.

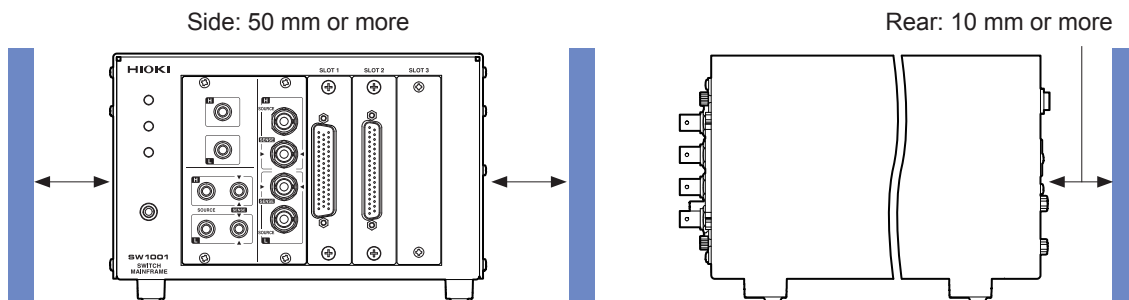

## Handling the device

This device may cause interference if used in residential areas. Such use must be avoided unless the user takes special measures to reduce electromagnetic emissions to prevent interference to the reception of radio and television broadcasts.

## Before installing the module

### WARNING



- To prevent an electric shock, before removing or replacing a module, confirm that the device is turned off and that all the measurement cables, connection cables, and the power cord are disconnected.
- Installing a module while the device is turned on may prevent detection of the contact state of relays on the module or result in short-circuiting of the measuring object. Damage of the device or module may cause the measuring object to be shorted or the instrument to fail.
- Be careful about short circuits when connecting a measuring object with electromotive force (battery, power supply, etc.).
- The maximum voltage of the device contact is 30 V (rms value) and 42.4 V (peak value) or 60 V (direct current). Do not directly connect a withstand voltage tester or an insulation resistance tester.

### CAUTION



- When installing or removing the module, be sure to observe the following precautions:
- Touch the **GND** terminal of the device with your hand to release static and then use antistatic gloves to perform procedures.
  - Hold the sheet metal area of the module. Directly touching the board with your hand may damage the circuit board due to static. If the measurement target has high resistance, the error component due to factors such as oil from your fingers may increase in magnitude.

## Before measurement

### DANGER



- Do not short-circuit between electrodes or terminals using a probe when measuring the battery or capacitor. Doing so may cause an electric arc, resulting in serious injury.
- Do not use the device or the connection cables that exceed its ratings or specifications. Doing so may damage the device or cause it to become hot resulting in a bodily injury.
- Do not use the instrument to be used in conjunction with the device outside of its ratings or specifications. Doing so may damage the instrument or cause it to become hot, resulting in a physical injury.

### WARNING



The maximum rated voltage between the module and ground is 60 V DC. To avoid an injury and damage to the device, ensure that voltage between channels never exceeds this limit. Prevent the voltage potential difference of the entire system from exceeding 60 V DC.

The measurement connector frame of the module is connected to the casing (metal) of the device as well as the protective ground terminal of the power inlet (conductive).



## Before starting the external control

### **WARNING**

To prevent an electric shock or damage to the device, always observe the following precautions when connecting the cables to the **EXT. I/O** terminals.



- Always turn off the device and any devices to be connected before making connections.
- Be careful to avoid exceeding the signal ratings of the **EXT. I/O** terminals.
- During operation, a wire becoming dislocated and contacting another conductive object can be a serious hazard. Use screws to secure the external connectors.
- Ensure that devices and systems to be connected to the **EXT. I/O** terminals are properly isolated from one another.

## Before connecting the communications cables

### **CAUTION**



- Use a common ground for both the device and the PC. Using different ground circuits will result in a potential difference between the device's ground and the computer's ground. If the communications cable is connected while such a potential difference exists, it may result in device malfunction or failure.
- Before connecting or disconnecting any communications cables, always turn off the device and the PC. Failure to do so could result in equipment malfunction or damage.
- After connecting the communications cables, tighten the screws on the connector securely. Failure to secure the connector could result in device malfunction or damage.
- To avoid device failure, do not disconnect the communications cables while communications are in progress.

## Precautions during shipment

Store the packaging in which the device was delivered, as you will need it when transporting the device.

## Disc precautions

- Exercise care to keep the recorded side of discs free of dirt and scratches. When writing text on a disc's label, use a pen or marker with a soft tip.
- Keep discs inside a protective case and do not expose to direct sunlight, high temperature, or high humidity.
- Hioki is not liable for any issues your computer system experiences in the course of using this disc.

## 1.1 Overview of Product

This device is a module type switching system that is ideal for multi-channel measurement of batteries. You can choose a main frame from two choices according to the required number of channels. You can also choose a module from two module types according to the instrument to be used with the device (2-wire/4-wire module and 4-terminal pair module).

## 1.2 Features

### **Reduction of errors when measuring internal resistance**

When AC low resistance measurement is performed using the BT4560 Battery Impedance Meter or the BT3562 Battery HiTester, the influence of electromagnetic induction (eddy current) on the measured value can be minimized.

### **Ability to switch measurement between two instruments**

For example, you can connect a BT3562 and DM7276 to the device and use it to switch between internal resistance measurement and high-precision OCV measurement.

### **Protection against short circuit with fuses**

To protect batteries to be measured if a short circuit occurs in a channel, a protective fuse is built into each channel.

# 1.3 Parts Names and Functions

## Front

The illustration shown here is for the SW1001.

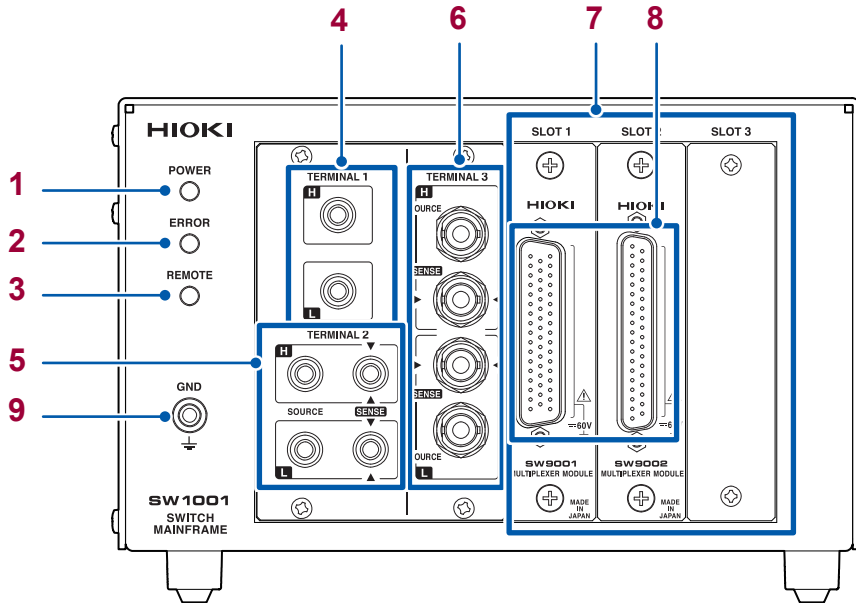

| No. | Name                               | Description   | Reference                     |
|-----|------------------------------------|---|-------------------------------|
| 1   | <b>POWER lamp</b>                  | Lights up when the main frame power is on.  | p.23                          |
| 2   | <b>ERROR lamp</b>                  | Lights up for self-test at the time of startup and when an error, such as a communications error, occurs.           | p.23<br>p.126                 |
| 3   | <b>REMOTE lamp</b>                 | Lights up when communications data is received.   | p.86                          |
| 4   | <b>TERMINAL 1</b>                  | Used to connect a 2-wire instrument.  | p.20                          |
| 5   | <b>TERMINAL 2</b>                  | Used to connect a 4-wire instrument.  | p.20                          |
| 6   | <b>TERMINAL 3</b>                  | Used to connect a 4-terminal pair (BNC terminal) instrument.  | p.21                          |
| 7   | <b>SLOT 1 to SLOT 3</b>            | Used to attach the module.  | p.15                          |
| 8   | <b>Measurement cable connector</b> | Used to connect the measurement cable to each module. For more details, see the chapter for the multiplexer module. | p.5<br>p.18<br>p.133<br>p.139 |
| 9   | <b>GND terminal</b>                | Ground for the device. Connected to the ground.   | p.36                          |

## Rear

The illustration shown here is for the SW1001.

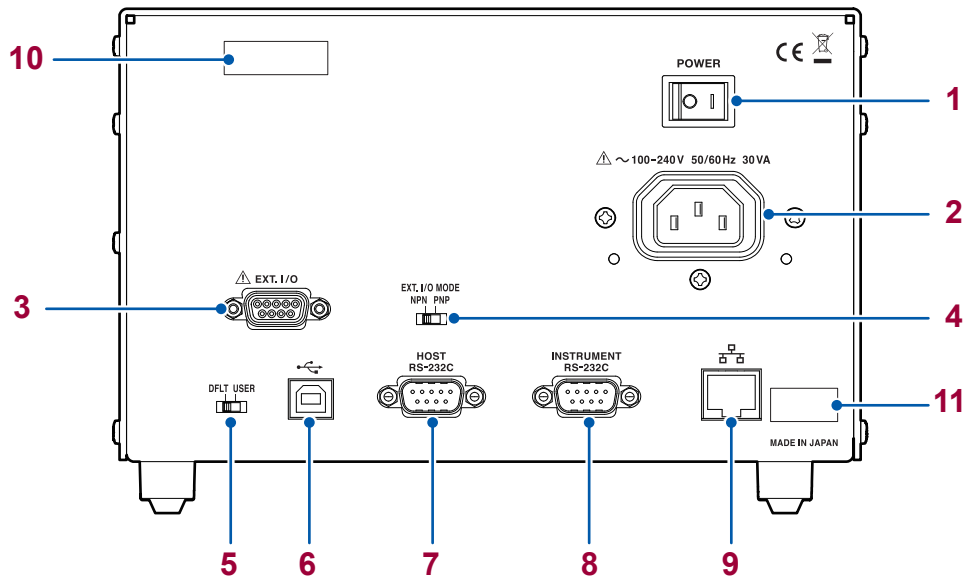

| No.       | Name                                     | Description   | Reference |
|-----------|--|---|-----------|
| <b>1</b>  | <b>Power switch</b>                      | Turns on/off the power.   | p.23      |
| <b>2</b>  | <b>Power inlet</b>                       | Used to connect the provided power cord.  | p.23      |
| <b>3</b>  | <b>EXT. I/O terminal</b>                 | Used to connect the device to be externally controlled.   | p.51      |
| <b>4</b>  | <b>EXT. I/O MODE change-over switch</b>  | Left: Sinking current (NPN), Right: Sourcing current (PNP)  | p.50      |
| <b>5</b>  | <b>Communication setting mode switch</b> | Perform communication using fixed settings when the communication settings are unknown.   | p.22      |
| <b>6</b>  | <b>USB connector</b>                     | Used to connect the PC.   | p.64      |
| <b>7</b>  | <b>HOST RS-232C connector</b>            | Used to connect the PC.   | p.66      |
| <b>8</b>  | <b>INSTRUMENT RS-232C connector</b>      | Used to connect the RS-232C connector of the instrument for scan measurement.   | p.70      |
| <b>9</b>  | <b>LAN connector</b>                     | Used to connect the PC.   | p.60      |
| <b>10</b> | <b>Serial number</b>                     | The serial number consists of 9 digits. The first two (from the left) indicate the year of manufacture, and the next two indicate the month of manufacture. Required for production control. Do not peel off the label. | —         |
| <b>11</b> | <b>MAC address</b>                       | MAC address of the LAN.   | p.105     |

## 1.4 Block Diagram

The configuration of this device is shown in the following block diagram

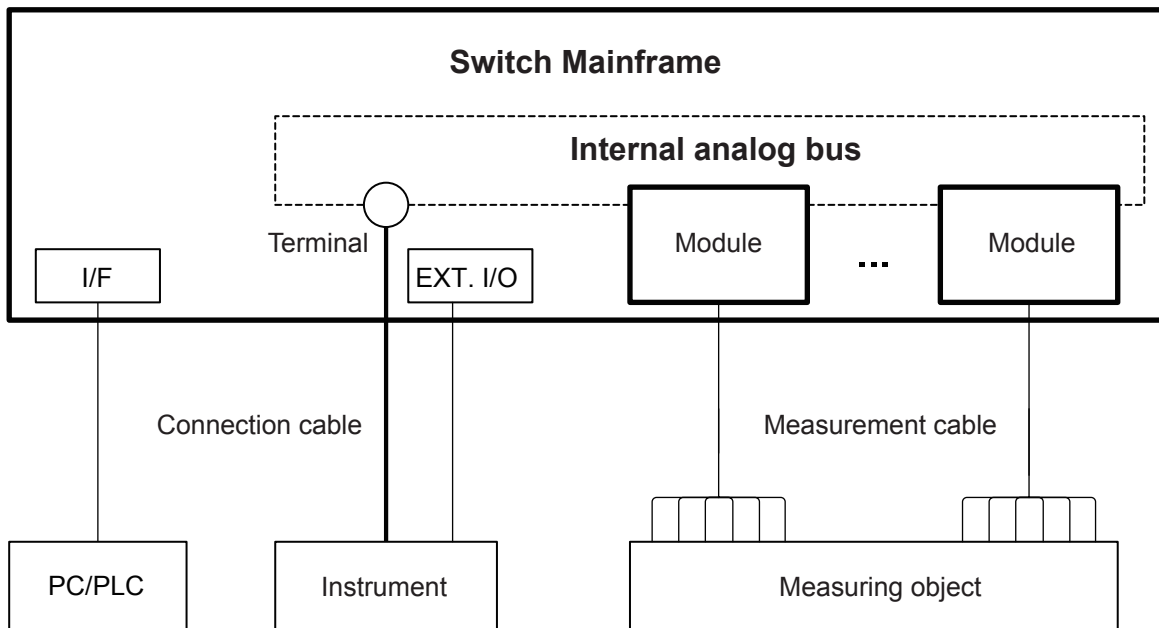

## 1.5 Glossary

| Terms             | Description   | Reference |
|-------------------|---|-----------|
| Measurement cable | Connects the measuring object and the module.<br>It is prepared by the customer.  | p. 143    |
| Connection cable  | Connects the switch mainframe and instrument.<br>Prepare the optional cable.  | p. 19     |
| Terminal          | Connects the instrument.<br>The terminal to be used varies depending on the connection method (2-wire/4-wire/4-terminal pair)   | p. 28     |
| Module            | For the switching circuit.<br>The connection method varies depending on the module type.  | p. 129    |
| Slot              | Used to attach the module.<br>The number of slots varies depending on the switch mainframe type.  | p. 30     |
| Channel           | Channel inside the module.<br>Specify the slot and channel and select the measuring object.   | p. 30     |
| Analog bus        | Common analog signal inside the switch mainframe.<br>The analog buses for 4 systems are built in.<br>The analog bus to be used is determined based on the connection method.  | p. 27     |
| Channel relay     | Switches the channel inside the module.   | p. 27     |
| Bus relay         | Connects the measurement signal selected for the channel relay to the analog bus.<br>It is built into the module.<br>Switching the bus relay allows you to select the connection method.  | p. 27     |
| Connection method | You can select the measurement connection from 2-wire, 4-wire, or 4-terminal pair.<br>Selecting a connection method determines the connection terminal for the instrument.  | p. 28     |
| Shield            | For the measurement cable (cable for the measuring object).<br>The destination to which the shield is connected inside the module can be switched.<br>Switching the connection destination can reduce the influence of noise depending on the instrument to be used or the measurement environment. | p. 29     |
| Scan              | Switches the pre-registered channel (scan list) in sequence.<br>Connecting the instrument and this device using EXT. I/O enables the channel to be switched and trigger measurement to be performed automatically.  | p. 39     |

## 1.6 Measurement Flowchart

Thoroughly read “Usage Notes” (p.4) beforehand.

### Installation, connection, and turning on of power

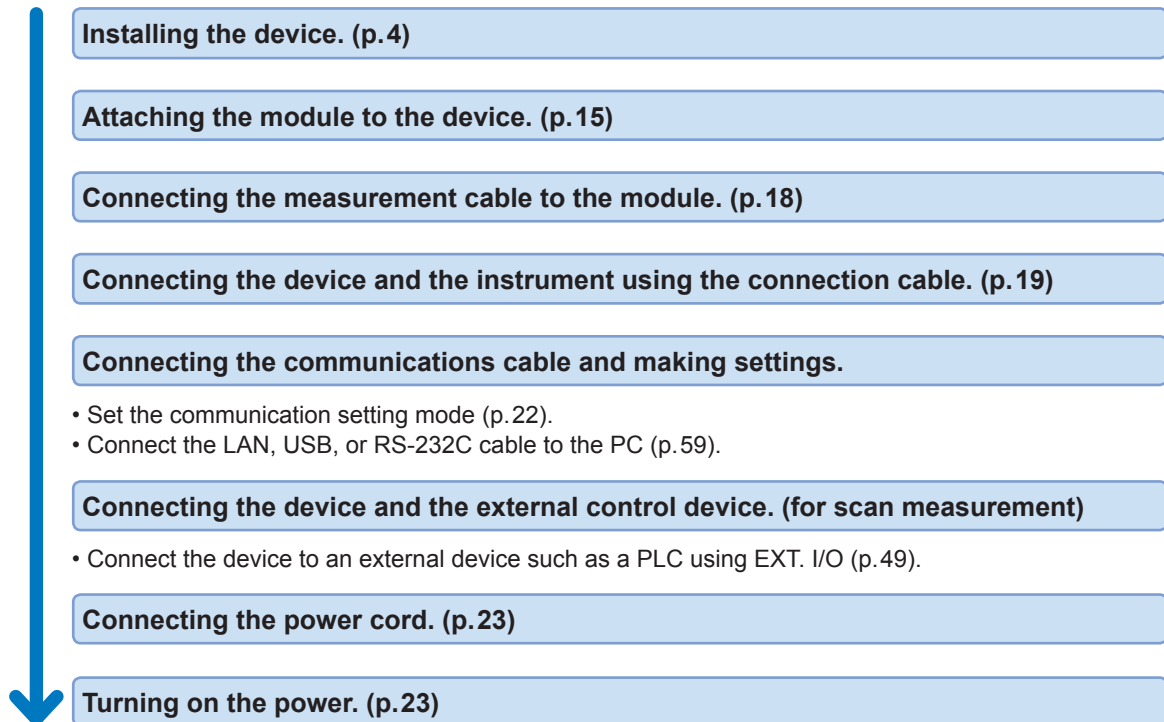

### Inspection before measurement (p.25)



### Setting before measurement

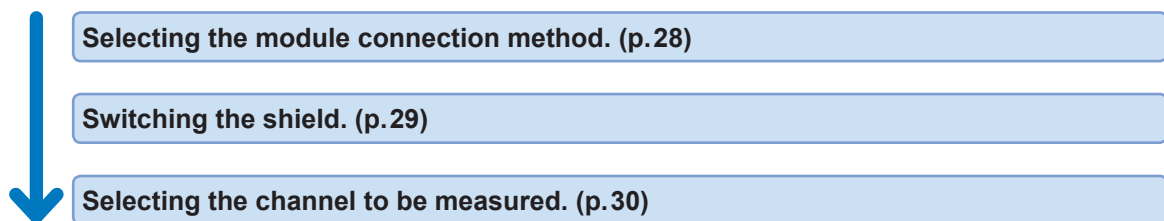

### Starting the measurement

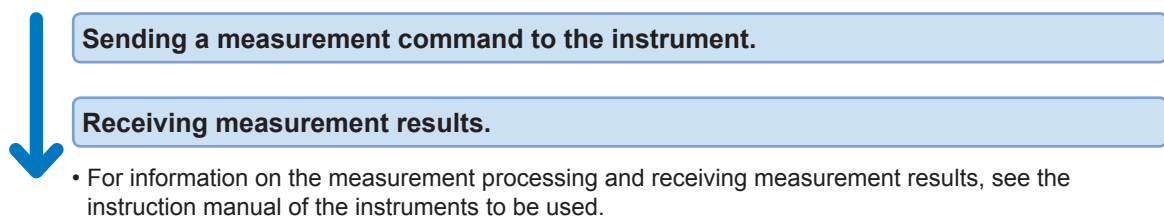

### Ending the measurement

- Turning off the power. (p.23)

## 2.1 Connecting Instruments and Controlling the Device

This section describes how to connect one or more measuring instruments and control the device. A PC or PLC must be connected in order to control the device. A PC or PLC connection is also required in order to control instruments and acquire measured values. The device utilizes the connection and control methods described below.

### Basic control

Connect the PC to the device and instrument via separate communications interfaces. Control the device to switch channels and control the instrument to configure settings, perform measurement, and acquire measured values.  
See: “3.2 Overview of Channel Switching” (p.27)

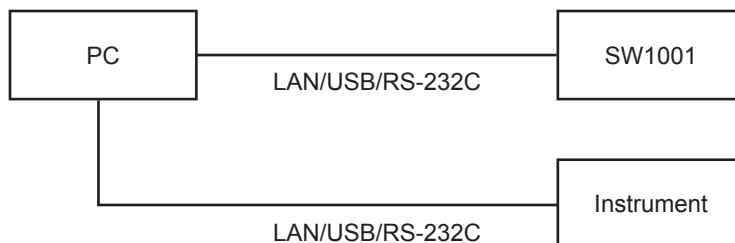

### Controlling an instrument via the device

You can also use the device’s functionality for forwarding communication commands to control instruments simply by sending commands to the device.  
See: “8.6 Communication Command Forwarding Function” (p.69)

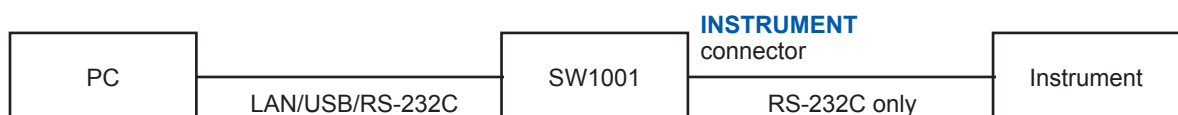

### Performing automatic scan measurement using EXT. I/O

You can switch channels and perform a series of measurements in accordance with a previously created scan list by connecting the device and an instrument via the EXT. I/O interface. You can also acquire measured values by using the instrument’s data output function (to automatically send measured values) or memory function.  
See: “4 Scan Function” (p.39)

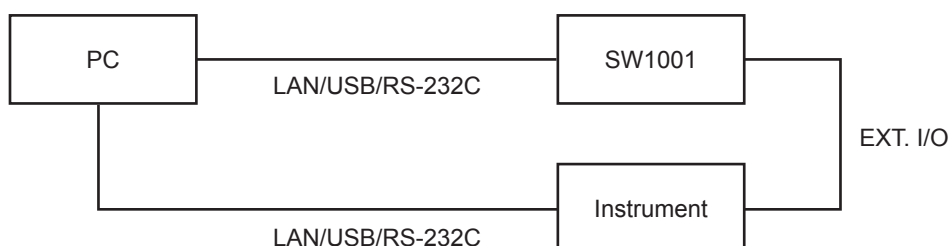



### Performing automatic scan measurement using EXT. I/O (using the communication command forwarding function)

Furthermore, you can perform automatic scan measurement over a single communications interface by using the device's communication command forwarding function.

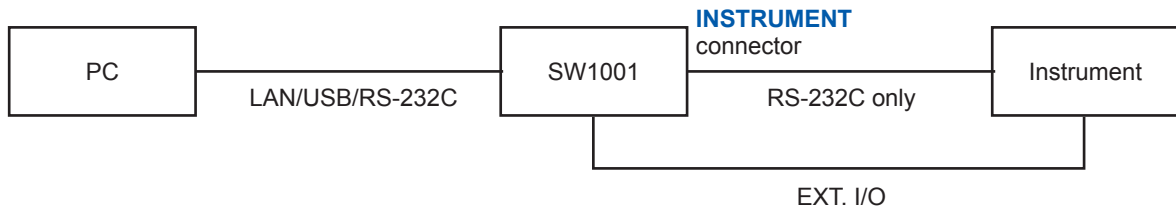

### Connecting two instruments

You can perform measurement by connecting two instruments to the device.  
See: "3.5 Measurement between Two Instruments" (p.32)

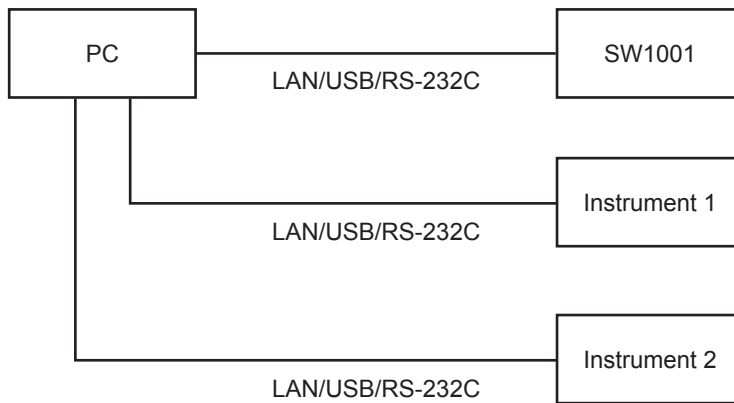

## 2.2 Installing the Module

Thoroughly read “Before installing the module” (p.5) beforehand.

The following settings are initialized when you install a new module into a slot or change the type of module installed in a given slot.

- Connection method
- Shield switching
- Channel delay
- Scan list

Required items: Phillips screwdriver (No. 2), antistatic gloves

2

Preparation for Measurements

**Front**



**1** GND

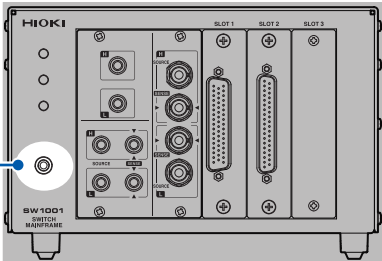

**1** Touch the **GND** terminal with bare hands.

**2** Wear antistatic gloves.

---

**Rear**

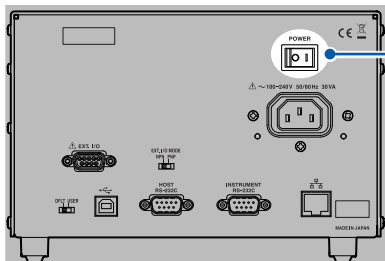

**3** POWER

**3** Turn off the device.

---

**Front**

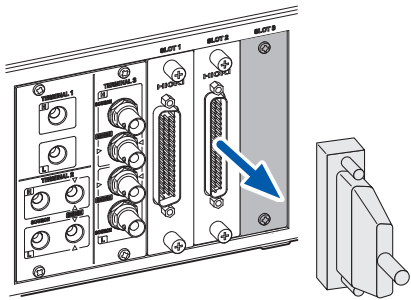

**4** Remove all the measurement cables connected to the device and module.

(To prevent electric shock and short circuit of the measuring object.)

---

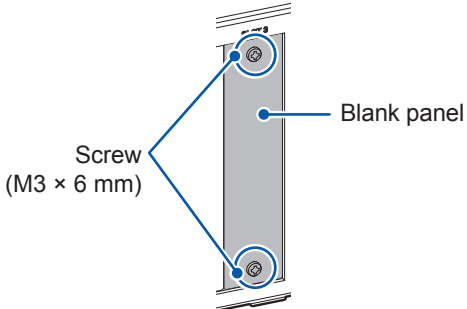

Screw (M3 × 6 mm)

Blank panel

**5** Loosen the two screws (M3 × 6 mm) and then remove the blank panel.

Store the blank panel and screws. You need the screws when using the device after removing the module.

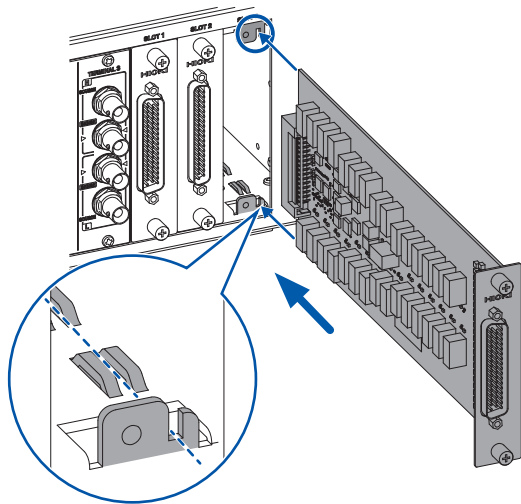

Align with the guide rail

**6** Insert the module to the back.

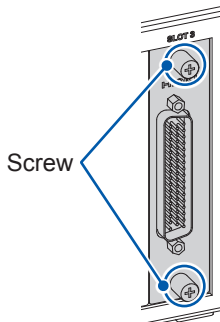

Screw

**7** Tighten the two screws to secure the module in place.

## 2.3 Removing the Module

Required items: Phillips screwdriver (No. 2), antistatic gloves

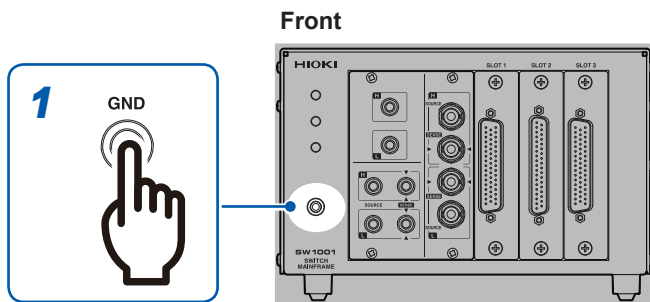

**1** Touch the **GND** terminal with bare hands.

**2** Wear antistatic gloves.

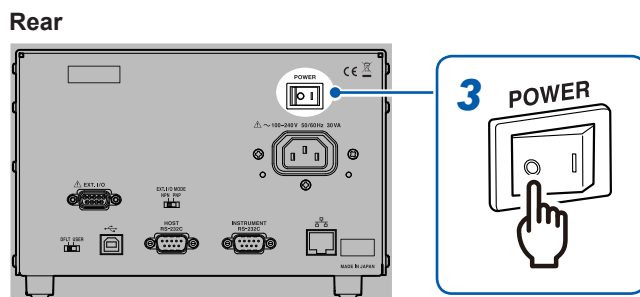

**3** Turn off the device.

Front

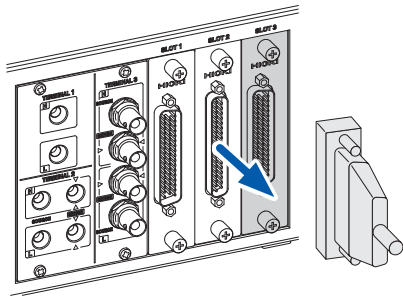

**4** Remove all the measurement cables connected to the device and module.

(To prevent electric shock and short circuit of the measuring object.)

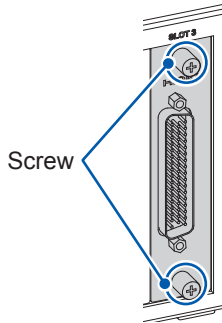

**5** Loosen the two screws.

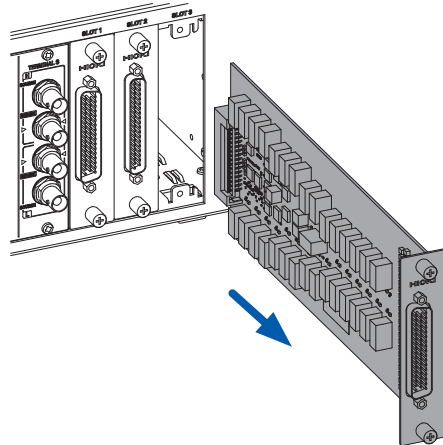

**6** Pull out the module.

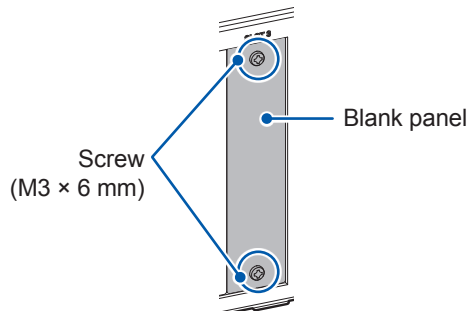

**7** Attach the blank panel and tighten the two screws (M3 × 6 mm) to secure the panel.

## 2.4 Connecting the Measurement Cable

### WARNING



Connect the measurement cable with the measuring object disconnected from the measurement cable. The measuring object may be shorted depending on the condition of the module switching circuit.

Please provide a suitable measurement cable.  
See: "12.1 Measurement cable" (p.143)

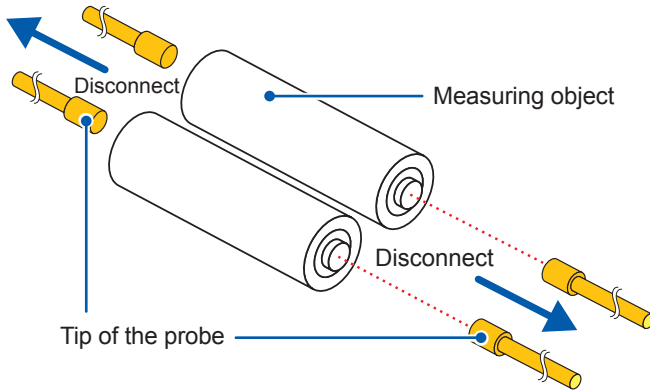

- 1** Turn off the device.
- 2** Disconnect the probe from the measuring object.

Front

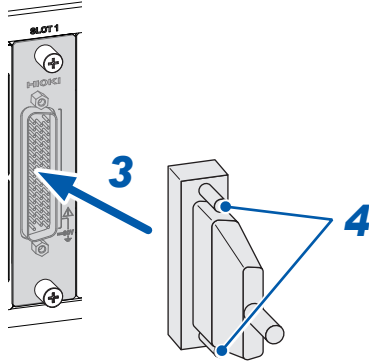

- 3** Connect the measurement cable connector to the module's connector.
- 4** Secure the measurement cable connector using the screws.

For information on connecting the measuring object, see the instruction manual of each instrument.

## 2.5 Connecting the Connection Cable

The connection cable is optional (p.2).

Connect the device to the instrument.

For information on connecting the instrument, see the instruction manual of each instrument.

Front

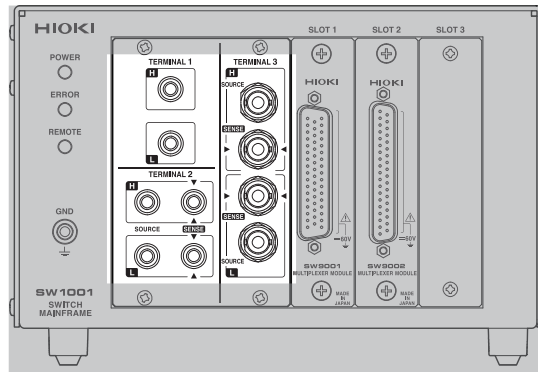

Select the terminal and connection cable to be connected on the instrument to be connected.

| Instrument example | Model  | Terminal   | Connection cable | Connection method | Module |
|--------------------|--------|------------|------------------|-------------------|--------|
| Voltmeter          | DM7276 | TERMINAL 1 | L4930            | 2-wire            | SW9001 |
|                    |        |            |                  |                   | SW9002 |
| Battery tester     | BT3562 | TERMINAL 2 | L2108            | 4-wire            | SW9001 |
| Battery tester     | BT4560 | TERMINAL 3 | L2004            | 4-terminal pair   | SW9002 |
| LCR meter          | IM3590 |            |                  |                   |        |

## ! CAUTION



**TERMINAL 2** and **TERMINAL 3** are internally conducted. Do not connect the instrument to **TERMINAL 2** and **TERMINAL 3** at the same time. Doing so may damage the instrument.

### TERMINAL 1

- 1** Turn off the device.
- 2** Connect the connection cable to **TERMINAL 1**.

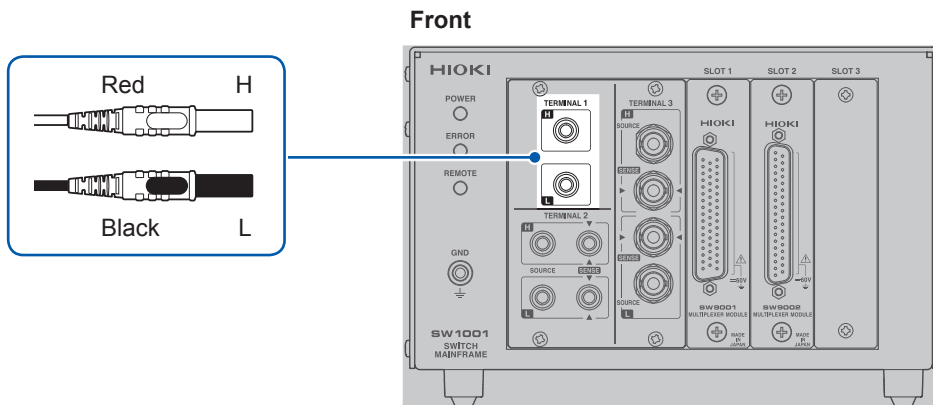

- 3** Connect the other end of the connection cable to the instrument.

### TERMINAL 2

- 1** Turn off the device.
- 2** Connect the connection cable to **TERMINAL 2**.

Connect the connection cable so that the red ▼ mark of the device and the ▲ mark of the red lead wire match and the black ▼ mark of the device and the ▲ mark of the black lead wire match.

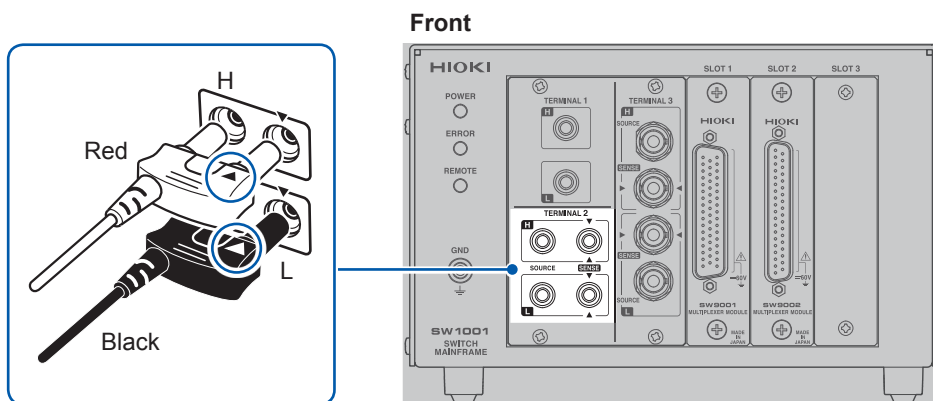

- 3** Connect the other end of the connection cable to the instrument.

## TERMINAL 3

- 1** Turn off the device.
- 2** Connect the connection cable to **TERMINAL 3**.

Match the cable and the connection terminal signal.

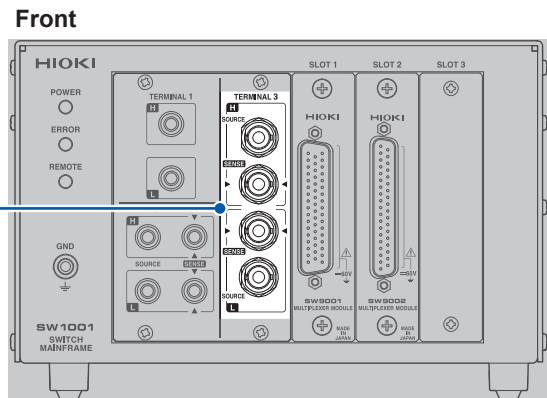
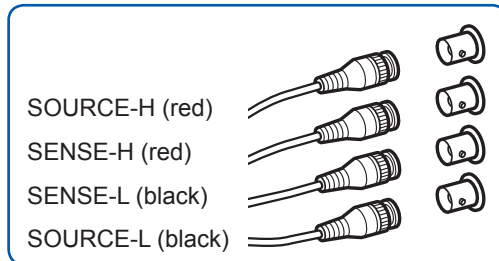

1. Check the direction of the grooves of the BNC connector. The grooves should fit into the connector guide of the device.
2. Align the grooves of the BNC connector with the connector guide of the device and insert the BNC connector.
3. Turn the BNC connector to the right to lock it.

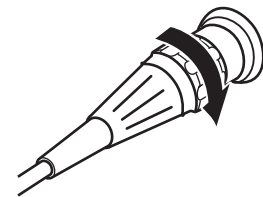
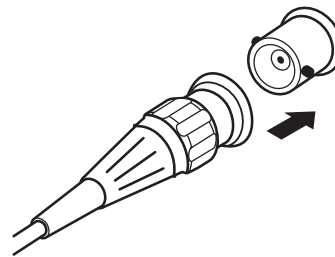
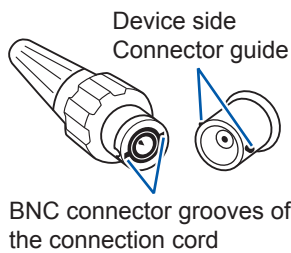

- 3** Connect the other end of the connection cable to the instrument.

| Connection cable terminal | Instrument terminal |        |
|---------------------------|---------------------|--------|
|                           | BT4560              | IM3590 |
| SOURCE-H (red)            | SOURCE-H (red)      | Hcur   |
| SENSE-H (red)             | SENSE-H (red)       | Hpot   |
| SENSE-L (black)           | SENSE-L (black)     | Lpot   |
| SOURCE-L (black)          | SOURCE-L (black)    | Lcur   |



## 2.6 Setting the Communication Setting Mode

The device uses the communications interface for control. You can select the fixed setting mode for initial communication settings or the user setting mode for user settings using the switch on the rear of the device. Specify the communication settings according to the interface to be used in the user setting mode. Reference: “8.1 Interface Overview and Features” (p.59)

Rear

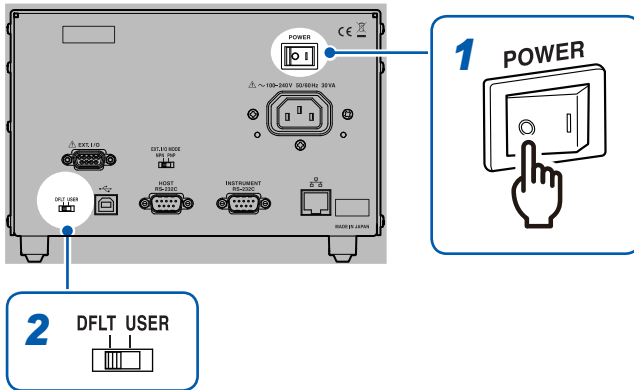

- 1** Check that the power switch is off (○).
- 2** Change the communication setting mode using the communication setting mode switch.

| Switch      | Communication setting mode | Device setting description  |
|-------------|----------------------------|---|
| <b>DFLT</b> | Fixed setting mode         | <p>All of USB, RS-232C, and LAN can be used. Communications are performed using the specified communication settings.</p> <ul style="list-style-type: none"> <li>• USB<br/>No setting item</li> <li>• RS-232C<br/>Transmission speed: 9600 bps, data bits: 8; stop bit: 1; parity check: none; flow control: non</li> <li>• LAN<br/>IP address: 192.168.0.254<br/>Subnet mask: 255.255.255.0<br/>Default gateway: 0.0.0.0 (None)<br/>Communication command port number: 23</li> </ul>   |
| <b>USER</b> | User setting mode          | <p>All of USB, RS-232C, and LAN can be used. Use the communication settings that are specified using the following communication commands.</p> <ul style="list-style-type: none"> <li>• USB<br/>No setting item</li> <li>• RS-232C<br/>:SYSTEM:COMMunicate:RS232C:SPEED &lt;Transmission speed&gt;<br/>Reference: “(8) RS-232C settings” (p. 103)</li> <li>• LAN<br/>:SYSTEM:COMMunicate:LAN:IPAddress &lt;IP address&gt;<br/>:SYSTEM:COMMunicate:LAN:SMASK &lt;Subnet mask&gt;<br/>:SYSTEM:COMMunicate:LAN:GATeway &lt;Gateway address&gt;<br/>:SYSTEM:COMMunicate:LAN:CONTRol &lt;Port No.&gt;<br/>:SYSTEM:COMMunicate:LAN:UPDate<br/>Reference: “(9) LAN settings” (p. 103)</li> </ul> |

## 2.7 Connecting the Power Cord

Be sure to thoroughly read the separate document “Operating Precautions” before use.

Rear

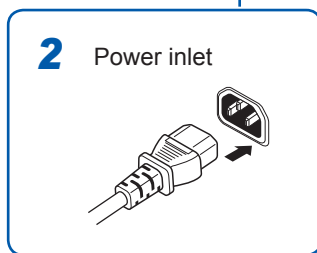
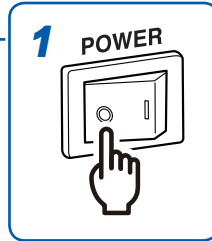
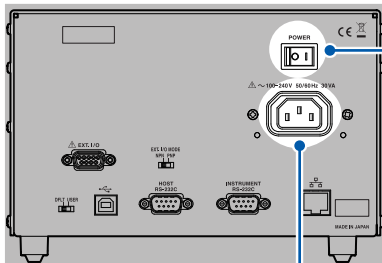

- 1 Check that the power switch is off (O).
- 2 Check that the power voltage is within the range indicated on the rear of the device and connect the power cord to the power inlet.
- 3 Connect the plug of the power cord to the outlet.

2

Preparation for Measurements

## 2.8 Turning on/off the Power

Use the power switch on the rear of the device to turn on/off the power.

Rear

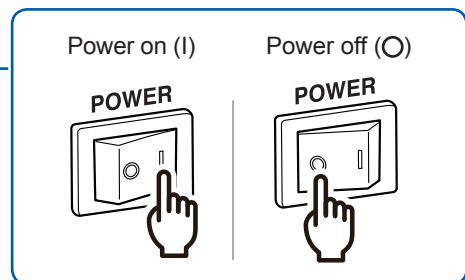
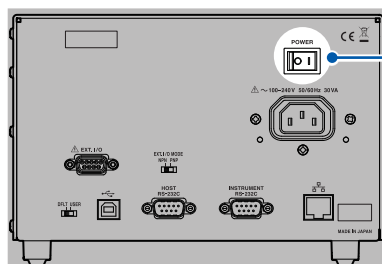

The front **POWER** lamp lights up when the device is turned on, and a self-test is executed. When an error occurs, the **ERROR** lamp on the front lights up. If an error occurs during self-test, communications and control using EXT. I/O become disabled.

Front

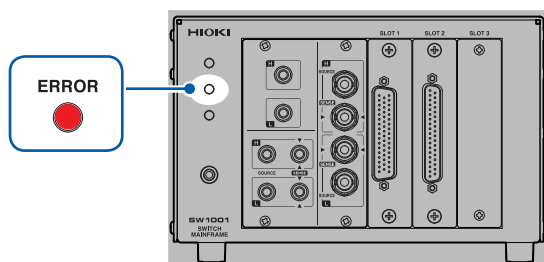

## 2.9 When the Power is Turned on

| Item                         | Initialization description   |
|------------------------------|--|
| Channel relay                | All relays open  |
| Bus relay                    | All relays open  |
| EXT. I/O CLOSE output signal | Off  |
| Connection method            | Settings (for each slot) are saved with the settings backup command. |
| Shield switching             | Settings (for each slot) are saved with the settings backup command. |
| Scan settings                | Settings are saved with the settings backup command.                 |
| Channel delay settings       | Settings are saved with the settings backup command.                 |
| Communication settings       | Settings are saved with the settings backup command.                 |

See: "Backing up settings" (p. 105)

# 3

## Channel Switching

Thoroughly read "Usage Notes" (p. 4) beforehand.

### 3.1 Inspection before Measurement

Verify that it operates normally to ensure that no damage occurred during storage or shipping. If you find any damage, contact your authorized Hioki distributor or reseller .

#### Inspecting the device and peripheral devices

| Check item   | Action   |
|--|--|
| Is the sheath of the power cord normal without any damage or exposed metal part?   | Damage may cause an electric shock or a short circuit accident. Do not use it.<br>Contact your authorized Hioki distributor or reseller. |
| Are the sheaths of the measurement cables or connection cables to be used normal without any damage or exposed metal part? | Damage may cause an electric shock. Stop using it and replace it with a specified one  |
| Is the device normal without any damage?   |  |

## Checking for relay contact welding

If a relay contact welds, the battery of the measuring object may short or the channels may be connected in parallel, resulting in improper measurement. You can check that the relays are not welded according to the following procedure.

- 1** Short all the module terminals.
- 2** Send inspection command: `TEST:RELAYSHORT <No. of slot to be inspected>, CH`, and set the test state of the channel relay.  
Example: Inspect the channel relay of **SLOT 1**.  
`:TEST:RELAYSHORT 1, CH`
- 3** Check that the terminals of the shorted modules and the following points of the terminals on the main frame are not electrically connected.

| Continuity inspection points |
|------------------------------|
| TERMINAL 1, H                |
| TERMINAL 1, L                |
| TERMINAL 2, SENSE H          |
| TERMINAL 2, SENSE L          |
| TERMINAL 2, SOURCE H         |
| TERMINAL 2, SOURCE L         |
| TERMINAL 3, SOURCE H shield  |
| TERMINAL 3, SOURCE L shield  |

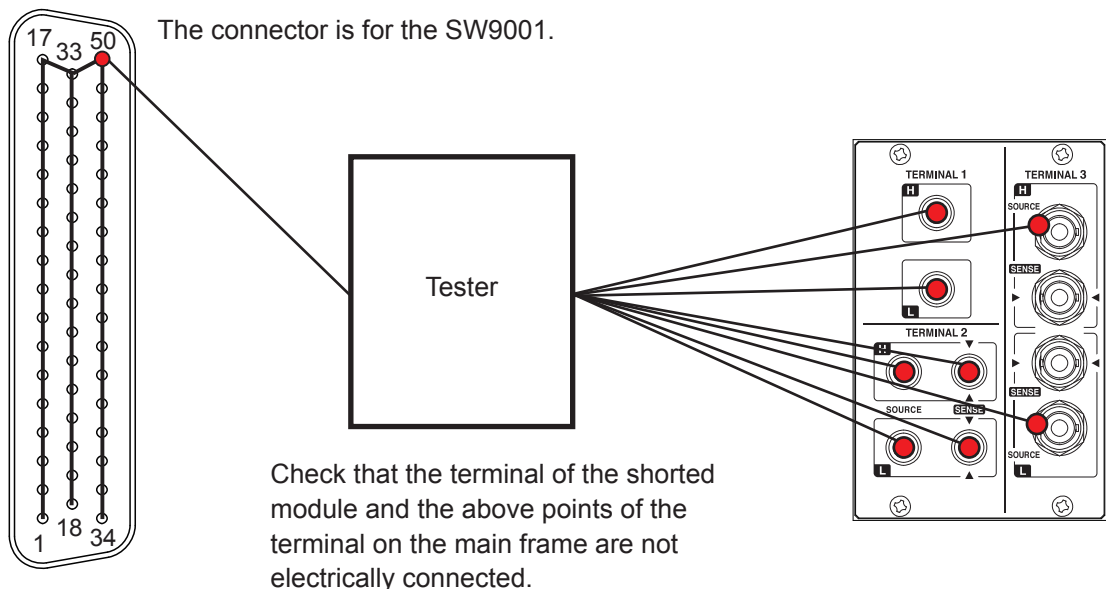

- 4** Send inspection command: `TEST:RELAYSHORT <No. of slot to be inspected>, BUS`, and set the test state of the bus relay, then confirm step **3**.
- 5** Send inspection command: `TEST:RELAYSHORT <No. of slot to be inspected>, OPEN`, and end the inspection for this slot.
- 6** Perform steps **1** to **5** for all the slots.

Module relay contact may be weld if it was conducted during inspection. Stop the use and contact your authorized Hioki distributor or reseller.

## 3.2 Overview of Channel Switching

This device connects to the internal analog bus by switching the relay of each module channel. The internal analog bus is connected to the terminal for connecting the instrument. The device is all controlled by communication commands. For details about the command, refer to the description of each item.

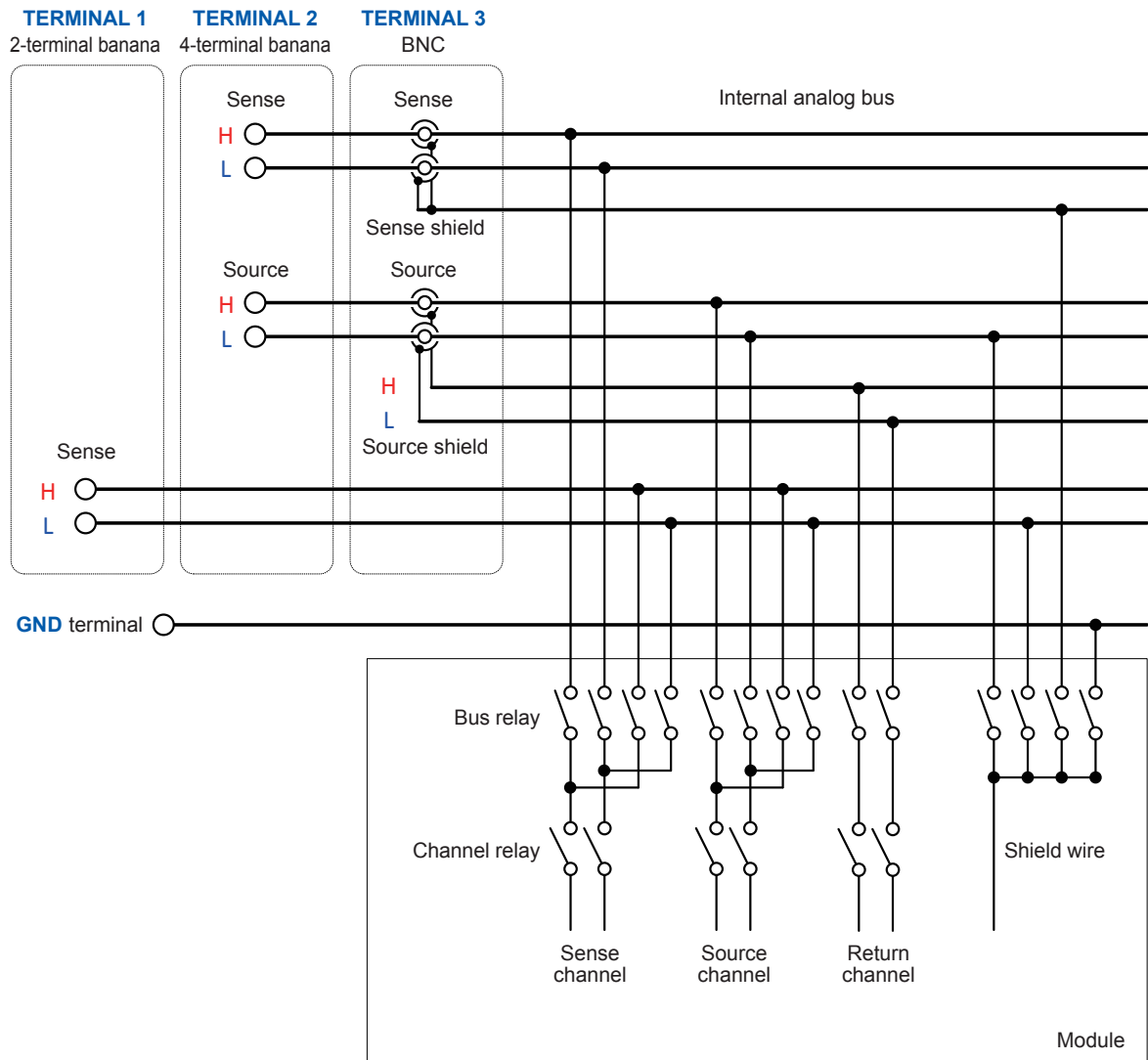

- The sense shield for **TERMINAL 3** (BNC terminal) is common (short circuit) for H and L.
- The diagram for wire connection inside the module is conceptual and differs from the actual module connection. See the wiring diagram for each module.

Reference: Switching wiring diagram (p. 132, p. 138)

Select the channel to be measured using the channel relay and specify the terminal to which the channel is to be connected (select the connection method) using the bus relay. The selected channel can be measured using an instrument.

The sense and source for **TERMINAL 2** (4-terminal banana terminal) and **TERMINAL 3** (BNC terminal) use a common analog bus (electrically connected).

### CAUTION



Do not connect **TERMINAL 2** and **TERMINAL 3** to the instrument at the same time. Doing so may damage the instrument.

## 3.3 Procedure for Switching the Channel

Switch the channel according to the following setting and procedure.

- Selecting the connection method
- Switching the shield
- Selecting the channel

### Selecting the connection method

The connection method can be selected for each slot. Selecting the connection method determines the terminal of the connection destination (instrument).

| Module | Connection method | Instrument example | Model  | Terminal   | Connection cable |
|--------|-------------------|--------------------|--------|------------|------------------|
| SW9001 | 2-wire            | Voltmeter          | DM7276 | TERMINAL 1 | L4930            |
| SW9002 |                   |                    |        |            |                  |
| SW9001 | 4-wire            | Battery tester     | BT3562 | TERMINAL 2 | L2108            |
| SW9002 | 4-terminal pair   | Battery tester     | BT4560 | TERMINAL 3 | L2004            |
|        |                   | LCR meter          | IM3590 |            |                  |

Once the connection method is specified, it is retained. You do not have to specify the connection method every time the channel is switched.

Once the connection method is specified, all the channels become open. The shield wire is connected to the specified connection destination for each connection method. If you wish to switch a channel to another terminal, specify the connection method and then close the channel.

The number of channels that can be used varies depending on the module type and connection method as shown below.

| Module | Connection method | Number of channels | Signal type | Signal to be used  | Terminal to be used |
|--------|-------------------|--------------------|-------------|--------------------|---------------------|
| SW9001 | 2-wire            | 22                 | Sense       | CH1 to CH22        | TERMINAL 1          |
|        | 4-wire            | 11                 | Source      | CH1 to CH11        | TERMINAL 2          |
|        |                   |                    | Sense       | CH12 to CH22       |                     |
| SW9002 | 2-wire            | 6                  | Sense       | Sense: CH1 to CH6  | TERMINAL 1          |
|        | 4-terminal pair   | 6                  | Source      | Source: CH1 to CH6 | TERMINAL 3          |
|        |                   |                    | Return      | Return: CH1 to CH6 |                     |
|        |                   |                    | Sense       | Sense: CH1 to CH6  |                     |

If the SW9001 is set to 4-wire and the 4-wire selection channel is “n”, the following signals are used in pairs.

Source: CH n

Sense: CH (n+11)

| Item              | Communication command  |
|-------------------|--|
| Setting procedure | :SYSTem:MODuLe:WIRE:MODE <slot number>,<WIRE2/WIRE4/TP4>           |
| Setting example   | Set <b>SLOT 1</b> to 2-wire.<br>:SYST:MOD:WIRE:MODE 1,WIRE2        |
|                   | Set <b>SLOT 5</b> to 4-terminal pair.<br>:SYST:MOD:WIRE:MODE 5,TP4 |

## Switching the shield

When the connection method is selected, the shield wire is connected to the specified connection destination.

### Specified shield switching setting (shielding connection destination)

| Module | Connection method | Shield connection destination             |
|--------|-------------------|---|
| SW9001 | 2-wire            | <b>TERMINAL 1</b> , LOW terminal          |
|        | 4-wire            | <b>GND</b>                                |
| SW9002 | 2-wire            | <b>TERMINAL 1</b> , LOW terminal          |
|        | 4-terminal pair   | <b>TERMINAL 3</b> , sense shield terminal |

The destination for shielding connection can be switched as necessary (for each slot). Any time the connection method for a slot is changed, the switching shield will be reset to the specified value. To set the switching shield to a value other than the specified value, be sure to set the switching shield after setting the connection method.

### Destination for shield wire connection to be selected

| Module | Connection destination terminal  |
|--------|--|
| SW9001 | Not connected  |
|        | <b>GND</b>   |
|        | <b>TERMINAL 1</b> , LOW terminal   |
|        | <b>TERMINAL 2</b> , <b>TERMINAL 3</b> , source LOW terminal                  |
|        | <b>TERMINAL 3</b> , sense shield terminal                                    |
|        | <b>TERMINAL 1</b> , LOW terminal + <b>TERMINAL 3</b> , sense shield terminal |
| SW9002 | Not connected  |
|        | <b>GND</b>   |
|        | <b>TERMINAL 1</b> , LOW terminal   |
|        | <b>TERMINAL 3</b> , sense shield terminal                                    |

For the SW9001, the [**TERMINAL 1**, LOW terminal + **TERMINAL 3**, sense shield terminal] shielding connection destination terminal should only be used when connecting a BT3562 and DM7275/DM7276 at the same time when the DM7275/DM7276 contact check function is not operating properly.

Once the connection destination is specified, it is retained until the connection method is changed. You do not have to specify the connection destination every time the channel is switched. When the switching shield is set, all channels are set to open.

The source terminal for **TERMINAL 2** and sense terminal are common for **TERMINAL 3**.

| Item              | Communication command  |
|-------------------|--|
| Setting procedure | <code>:SYSTem:MODule:SHIeld &lt;slot No.&gt;,&lt;OFF/GND/TERMinal1/TERMinal2/TERMinal3/T1T3&gt;</code>               |
| Setting example   | Set the shield wire connection destination for <b>SLOT 1</b> to GND.<br><code>:SYST:MOD:SHI 1,GND</code>             |
|                   | Set the shield wire connection destination for <b>SLOT 5</b> to "not connected".<br><code>:SYST:MOD:SHI 5,OFF</code> |



## Selecting the channel

Select the slot and channel No.

When the channel is selected, the specified slot of channel relay is closed, as well as the bus relay is also closed due to the connection method.

| Item              | Communication command  |
|-------------------|--|
| Setting procedure | [ROUTE] : CLOSE <Slot and channel No.><br><Slot and channel No.> = Slot No. × 100 + CH No. |
| Setting example   | Select CH7 of SLOT 1.<br>:CLOS 107   |
|                   | Select CH22 of SLOT 12.<br>:CLOS 1222  |

| Item              | Communication command       |
|-------------------|-----------------------------|
| Setting procedure | [ :ROUTE ] : OPEN           |
| Setting example   | Open all channels.<br>:OPEN |

### Restriction

Multiple channels cannot be closed simultaneously.

### Waiting for channel selection (switching) to complete

Switching operation is triggered by the channel selection command.

You can verify whether channel switching operation has completed by receiving the next query response. The switching operation time is included in the channel delay time.

See: "3.7 Channel Delay Function" (p. 37)

Waiting for channel switching operation to complete

| Item                 | Communication command  |
|----------------------|--|
| Confirming procedure | *OPC<br>Response: 1<br>Waits for the present operation to complete and returns the value 1.<br>The subsequent command will be made to wait until this command completes. |
| Confirming example   | Select CH7 of SLOT 1 and wait for switching operation to complete.<br>:CLOS 107<br>*OPC?<br>1 (receive a response = switching operation complete)                        |

## 3.4 Channel Switching Operation

When the channel is selected (closed), channel switching is performed according to the following flow.

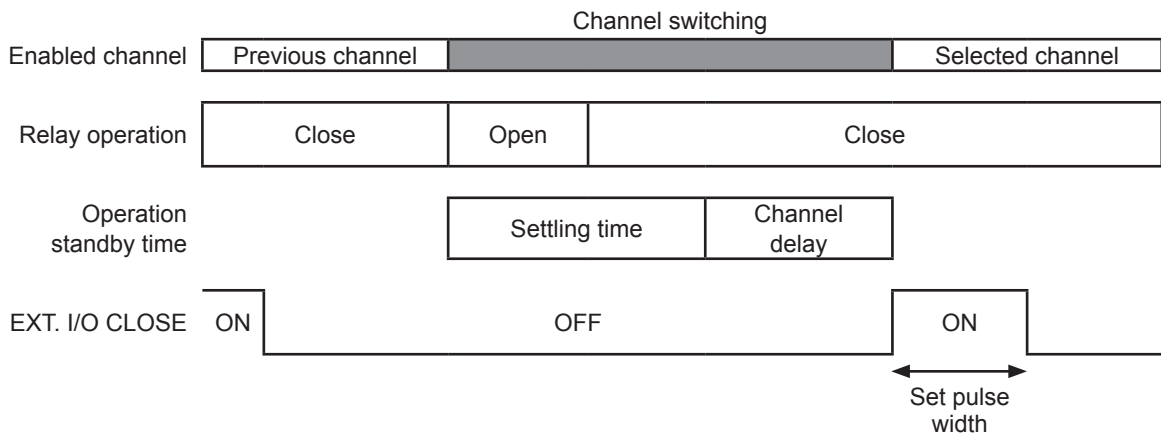

If the next channel is closed before the CLOSE signal pulse reaches the set pulse width, CLOSE signal pulse will automatically turn off.

After the previous channel relay is opened, the selected channel relay is closed (break before make).

Channel switching cannot be overlapped (make before break).

In channel switching within the same slot, the bus relay is not opened and only the channel relay is switched.

If the channel for a different slot is selected, the bus relay and channel relay of the previous slot are opened and the bus relay and channel relay of the selected slot are closed.

After the channel relay is closed and then the settling time that is automatically set and the channel delay time that is specified by the customer elapse, channel switching operation is complete and the CLOSE output signal of EXT. I/O is turned on (pulse output at the set pulse width).

## 3.5 Measurement between Two Instruments

Changing the connection method enables measurement to be performed by switching between two instruments according to the application.

**Example: Measure the internal resistance of 8 batteries using BT3562 and measure the OCV using DM7276. (Use SLOT 1, 4-wire, CH1 to CH8.)**

- 1 Connect BT3562 to **TERMINAL 2** and DM7276 to **TERMINAL 1**.

| Instrument | Measurement item    | Module | Connection method | Channel selection | Terminal to be used |
|------------|---------------------|--------|-------------------|-------------------|---------------------|
| BT3562     | Internal resistance | SW9001 | 4-wire            | SLOT 1, CH1       | <b>TERMINAL 2</b>   |
|            |                     |        |                   | SLOT 1, CH2       |                     |
|            |                     |        |                   | SLOT 1, CH3       |                     |
|            |                     |        |                   | ⋮                 |                     |
|            |                     |        |                   | SLOT 1, CH8       |                     |
| DM7276     | OCV                 | SW9001 | 2-wire            | SLOT 1, CH12      | <b>TERMINAL 1</b>   |
|            |                     |        |                   | SLOT 1, CH13      |                     |
|            |                     |        |                   | SLOT 1, CH14      |                     |
|            |                     |        |                   | ⋮                 |                     |
|            |                     |        |                   | SLOT 1, CH19      |                     |

- 2 Set the connection method of **SLOT 1** to 4-wire.  
The signal is connected to **TERMINAL 2**.
- 3 Repeat channel selection and measurement using BT3562 for 8 channels (internal resistance measurement).
- 4 Set the connection method to 2-wire.  
The signal is connected to **TERMINAL 1**.
- 5 Repeat channel selection and measurement using DM7276 in the same way as for internal resistance measurement (OCV measurement).  
The sense wire for 4-wire CH1 to CH8 corresponds to 2-wire CH12 to CH19.

| Control example using communication command |  |
|---|--|
| [SW1001] :SYST:MOD:WIRE:MODE 1,WIRE4        | Set the <b>SLOT 1</b> connection method to 4-wire (connect to <b>TERMINAL 2</b> ). |
| [SW1001] :CLOSE 101                         | Select <b>SLOT 1</b> , CH1.  |
| [SW1001] *OPC?                              | Check that the channel relay has been closed.                                      |
| [SW1001] 1                                  | Receive a response "1" to the *OPC? query.   |
| [BT3562] :READ?                             | Execute single measurement using BT3562.   |
| [BT3562] 1.0258E-3                          | Receive measured values.   |
| [SW1001] :CLOSE 102                         | Select the next CH2.   |
| ...   | (Repeat until CH8.)  |
| [SW1001] :SYST:MOD:WIRE:MODE 1,WIRE2        | Set the <b>SLOT 1</b> connection method to 2-wire (connect to <b>TERMINAL 1</b> ). |
| [SW1001] :CLOSE 112                         | Select <b>SLOT1</b> , CH12 (4-wire CH1 sense).                                     |
| [SW1001] *OPC?                              | Check that the channel relay has been closed.                                      |
| [SW1001] 1                                  | Receive a response "1" to the *OPC? query.   |
| [DM7276] :READ?                             | Execute single measurement using DM7276.   |
| [DM7276] +03.764987E+00                     | Receive measured values.   |
| [SW1001] :CLOSE 113                         | Select the next CH13 (4-wire CH2 sense).   |
| ...   | (Repeat until CH19.)   |

**Example: Measure the internal resistance of 8 batteries using BT3562 and measure the OCV using DM7276. Then measure the external potential for batteries using the DM7276. (Use SLOT 1, 4-wire, CH1 to CH8 for internal resistance and OCV measurement. Use SLOT 2, 2-wire, CH1 to CH8 for external potential measurement for batteries.)**

**1** Connect BT3562 to **TERMINAL 2** and DM7276 to **TERMINAL 1**.

| Instrument | Measurement item                             | Module | Connection method | Channel selection | Terminal to be used |
|------------|--|--------|-------------------|-------------------|---------------------|
| BT3562     | Internal resistance                          | SW9001 | 4-wire            | SLOT 1, CH1       | TERMINAL 2          |
|            |  |        |                   | SLOT 1, CH2       |                     |
|            |  |        |                   | SLOT 1, CH3       |                     |
|            |  |        |                   | ⋮                 |                     |
|            |  |        |                   | SLOT 1, CH8       |                     |
| DM7276     | OCV  | SW9001 | 2-wire            | SLOT 1, CH12      | TERMINAL 1          |
|            |  |        |                   | SLOT 1, CH13      |                     |
|            |  |        |                   | SLOT 1, CH14      |                     |
|            |  |        |                   | ⋮                 |                     |
|            |  |        |                   | SLOT 1, CH19      |                     |
| DM7276     | External potential measurement for batteries | SW9001 | 2-wire            | SLOT 2, CH1       | TERMINAL 1          |
|            |  |        |                   | SLOT 2, CH2       |                     |
|            |  |        |                   | SLOT 2, CH3       |                     |
|            |  |        |                   | ⋮                 |                     |
|            |  |        |                   | SLOT 2, CH8       |                     |

**2** Set the connection method of **SLOT 1** to 4-wire.

The signal is connected to **TERMINAL 2**.

**3 Repeat channel selection and measurement using BT3562 for 8 channels (internal resistance measurement).**

**4 Set the connection method to 2-wire.**

The signal is connected to **TERMINAL 1**.

**5 Repeat channel selection and measurement using DM7276 in the same way as for internal resistance measurement (OCV measurement).**

The sense wire for 4-wire CH1 to CH8 corresponds to 2-wire CH12 to CH19.

**6 Set the connection method of SLOT 2 to 2-wire.**

Use **SLOT 2** for external potential for batteries since the measurement points are different.

The signal is connected to **TERMINAL 1**.

**7 Repeat channel selection and measurement using DM7276 (external potential measurement for batteries).**

| Control example using communication command |                             |  |
|---|-----------------------------|--|
| [SW1001]                                    | :SYST:MOD:WIRE:MODE 1,WIRE4 | Set <b>SLOT 1</b> to 4-wire (connect to <b>TERMINAL 2</b> ). |
| [SW1001]                                    | :CLOSE 101                  | Select <b>SLOT 1</b> , CH1.                                  |
| [SW1001]                                    | *OPC?                       | Check that the channel relay has been closed.                |
| [SW1001]                                    | 1                           | Receive a response "1" to the *OPC? query.                   |
| [BT3562]                                    | :READ?                      | Execute single measurement using BT3562.                     |
| [BT3562]                                    | 1.0258E-3                   | Receive measured values.                                     |
| [SW1001]                                    | :CLOSE 102                  | Select the next CH2.   |
|   | ...                         | (Repeat until CH8.)  |
| [SW1001]                                    | :SYST:MOD:WIRE:MODE 1,WIRE2 | Set <b>SLOT 1</b> to 2-wire (connect to <b>TERMINAL 1</b> ). |
| [SW1001]                                    | :CLOSE 112                  | Select <b>SLOT 1</b> , CH12 (4-wire CH1 sense).              |
| [SW1001]                                    | *OPC?                       | Check that the channel relay has been closed.                |
| [SW1001]                                    | 1                           | Receive a response "1" to the *OPC? query.                   |
| [DM7276]                                    | :READ?                      | Execute single measurement using DM7276.                     |
| [DM7276]                                    | +03.764987E+00              | Receive measured values.                                     |
| [SW1001]                                    | :CLOSE 113                  | Select the next CH13 (4-wire CH2 sense).                     |
|   | ...                         | (Repeat until CH19.)   |
| [SW1001]                                    | :SYST:MOD:WIRE:MODE 2,WIRE2 | Set <b>SLOT 2</b> to 2-wire (connect to <b>TERMINAL 1</b> ). |
| [SW1001]                                    | :CLOSE 201                  | Select <b>SLOT 2</b> , CH1.                                  |
| [SW1001]                                    | *OPC?                       | Check that the channel relay has been closed.                |
| [SW1001]                                    | 1                           | Receive a response "1" to the *OPC? query.                   |
| [DM7276]                                    | :READ?                      | Execute single measurement using DM7276.                     |
| [DM7276]                                    | +00.257139E+00              | Receive measured values.                                     |
| [SW1001]                                    | :CLOSE 202                  | Select the next CH2.   |
|   | ...                         | (Repeat until CH8.)  |

## 3.6 Precautions for Measurement

### Use in combination with BT3562 or BT3563

Contact check does not operate properly at 3000  $\Omega$  range. Also be aware that contact check cannot be performed properly in the voltage function, either.

### Use in combination with BT4560

Use the device with BT4560 for external trigger measurement or single measurement using the `:READ?` command.

When using the device for internal trigger (free running), the life time of the relay is shortened as the channel is switched during measurement (hot switching).

As the measurement current for BT4560 is 1.5 A (3 m $\Omega$  range), heat generation at the relay contact becomes high. With heat generation, the thermoelectric power may become high.

### Use in combination with DM7275 or DM7276

If a measurement accuracy of a few  $\mu\text{V}$  is required, there is an effect by the thermoelectric power due to coil heating of the channel relay. Minimize the close time of each channel to reduce this effect as much as possible. Use single measurement using the `:READ?` command or external trigger and open the channel immediately after the measurement (heating from the relay coil is controlled).

Measured value variation may be significant when connected at the same time as the IM3590. If you encounter this issue, enable the IM3590's trigger synchronous output function.

### Use in combination with IM3590

Execute open correction and short correction to each channel you will use.

Error might occur to open correction and short correction due to high frequency. (Set the frequency range you will correct when executing.)

Threshold value of the contact check might be larger than the setting.

Also, the inspection result of the contact state (the resistance value near the threshold) might vary.

### Relay operation time and stability time

The relay open/close operation waits for a contact operation time (settling time). The settling time is as follows.

| Channel switching time   |                           |
|--------------------------|---------------------------|
| Relay open settling time | Relay close settling time |

#### Settling time

| Relay open | Relay close | Channel switching |
|------------|-------------|-------------------|
| 5 ms       | 5 ms        | 11 ms             |

The relay contact operation is completed within the settling time, however, it may take some time for the relay to be stabilized depending on the instrument to be used or measuring object. Set the channel delay time or perform measurement after a sufficient delay time on the instrument

### Preventing relay contact welding

The relay contact may weld when relay switching is repeated with a large current flowing (also when the measuring object or instrument to be connected is capacitive). When relay contact welding occurs, the measuring object may be shorted. Periodic inspection is recommended.

Reference: "Checking for relay contact welding" (p. 26)

### **Influence of thermoelectric power**

Be aware of the thermoelectric power when a voltage accuracy of a few  $\mu\text{V}$  is required.  
Install the device and instrument in a constant temperature environment and fully adjust them to the ambient temperature before use.  
Especially prevent uneven temperatures at the terminal.  
When creating a measurement cable, use a connector and terminal of a material with low thermoelectric voltage, such as brass (nickel plate), pure copper (+ gold plate), etc.  
Exercise care to keep the contact surface clean.

### **High resistance and minute current measurement**

In a high humidity environment, high resistance or minute current measurement may be affected by leak current.  
Do not touch the module board with your bare hand. Grease can cause leak current, which may affect high resistance and minute current measurement.  
Do not bundle the measurement cables when measuring minute current. Doing so may cause leak current due to the capacity of the cables, resulting in an error in the measured value.

### **Caution regarding noise**

Do not bundle the measurement cables or connection cables for the instrument and the power line. Noise on the power line may cause malfunction of channel switching or an error in the measured value.  
When the measured value cannot be stabilized due to noise, connecting the ground (**GND** terminal) of the device and the ground of the instrument may improve the condition.

### **Caution regarding load**

When a load is applied to the measurement cable, the contact area of the connector becomes unstable and the contact resistance is increased, which can cause the measured value to be unstable.  
When attaching the module to the main frame, be sure to secure the panel using screws. If the panel cannot support the load when a vertical load is applied to the main frame, the module board is stressed and may malfunction.

## 3.7 Channel Delay Function

The delay time after channel switching can be specified. When the specified delay time elapses after the channel relay is closed, a CLOSE signal of EXT. I/O is output.

If the measurement response time for the instrument needs to be ensured, set the delay time.

The required delay time depends on the instrument to be used and the measuring object.

### Channel delay time setting example

| Model  | Delay time |
|--------|------------|
| BT4560 | 1 ms       |
| BT3562 | 10 ms      |
| 3561   | 3 ms       |
| DM7276 | 0 ms       |

The channel delay time can be specified for each slot. The same delay time is used for all channels within the slot.

For the switching sequence, see "3.4 Channel Switching Operation" (p. 31)

| Item              | Communication command  |
|-------------------|--|
| Setting procedure | <code>:SYSTem:MODule:DELay &lt;slot No.&gt;,&lt;delay time 0 to 9.999[s]&gt;</code>  |
| Setting example   | Set the channel delay time for <b>SLOT 1</b> to 0.01 sec. and for <b>SLOT 2</b> to 0 sec.<br><code>:SYST:MOD:DEL 1,0.01</code><br><code>:SYST:MOD:DEL 2,0</code> |





# 4 Scan Function

Thoroughly read "Usage Notes" (p.4) beforehand.

## 4.1 Overview of the Scan Function

For scanning, specify the channel range (scan list) in advance and switch the channel in order. Channel switching (scan channel moving forward) can be performed using EXT. I/O or communications. Connecting the switch mainframe and the instrument EXT. I/O can switch the channel and perform measurement in synchronization with the instrument.

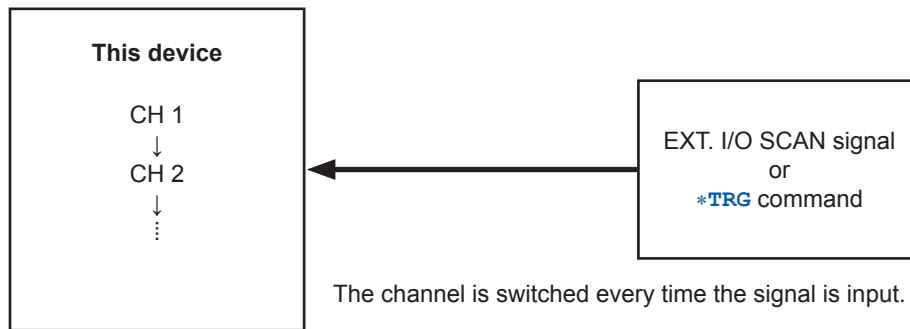

### Scanning in combination with the instrument

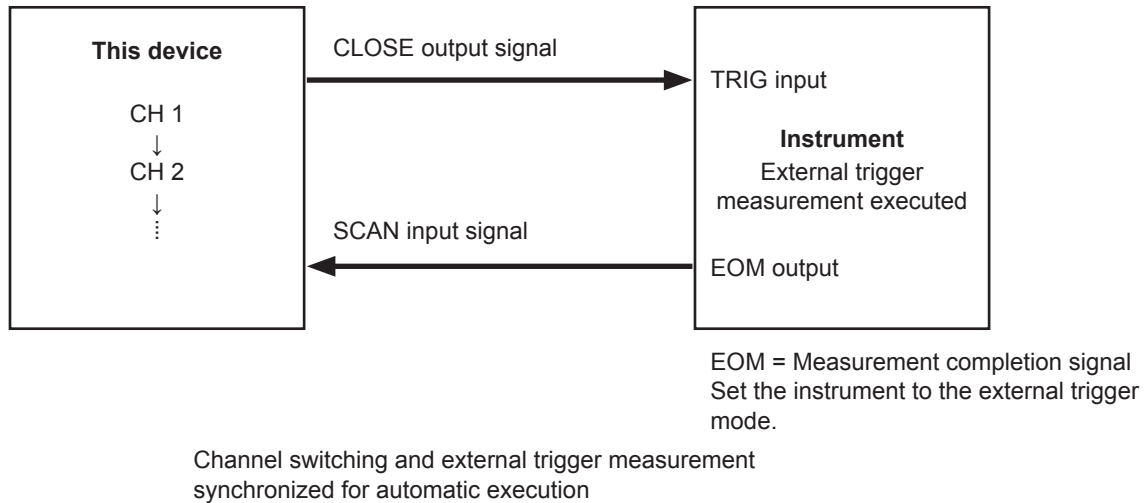

### Precautions when performing a scan when the device and instrument are connected via EXT. I/O

- Only one instrument can be used.
- Use either the instrument's data output function or its memory function to acquire measured values from the scan. For more information, please see the instrument's instruction manual.
- The EOM signal from the instrument may cause scan measurement to resume even if it has been stopped using the SCAN\_RESET signal or the **:ABORT** command.

For the EXT. I/O signal, see "Signal Functions" (p.52).

## 4.2 Setting the Scan Channel

The channels to be scanned need to be registered as a scan list.  
Specify the start and end channels. An individual channel list can also be specified

| Item                     | Communication command  |
|--------------------------|--|
| <b>Setting procedure</b> | <pre>[ :ROUTe] :SCAN&lt; (@Channel list) &gt; &lt; (@Channel list) &gt;</pre> <p>Channel list format</p> <pre>&lt;CH&gt; , &lt;CH&gt; , . . . , &lt;CH&gt;</pre> <p>Specify the channels to be measured individually.</p> <pre>&lt;CHm&gt; : &lt;CHn&gt;</pre> <p>Specify from CHm to CHn consecutively.</p> |
| <b>Setting example</b>   | <p>Scan CH1 of <b>SLOT 1</b> to CH22 of <b>SLOT 3</b>.<br/>:SCAN 101:322</p> <p>Scan CH1 and CH2 of <b>SLOT 1</b> and CH1, CH2, and CH5 of <b>SLOT 2</b>.<br/>:SCAN (@101,102,201,202,205)</p>   |

## 4.3 Setting the Trigger Source for Scan Operation

A trigger source for scan operation is set for STEP only.

| Trigger source | Scan operation  |
|----------------|---|
| <b>STEP</b>    | <p>Scanning is started by the SCAN input signal or *TRG command (the first channel is closed). Then the next scan channel is scanned every time the SCAN input signal or *TRG command is sent.</p> <p>STEP is set as the default setting. Normally select STEP and execute scanning while synchronizing with control of the instrument.</p> |

The commands to be set are as follows.

| Item                     | Communication command   |
|--------------------------|---|
| <b>Setting procedure</b> | <pre>:TRIGger:SOURce &lt;STEP&gt; &lt;STEP&gt;</pre> <p>STEP:<br/>External trigger. Scanning is performed with the SCAN input signal of EXT. I/O or the *TRG command. Scan operation moves along the steps every time the trigger is input.</p> |
| <b>Setting example</b>   | <p>Set to proceed with the next step every time the external trigger is input.<br/>:TRIG:SOUR STEP</p>  |

## 4.4 Scan Operation

Scanning is started by the SCAN signal of EXT. I/O or the communication **\*TRG** command. The scan channel is moved forward by the SCAN signal or the **\*TRG** command.

When the channel is the final channel, scanning is completed by the SCAN signal or the **\*TRG** command, and all relay is opened and goes back to the beginning of the scan list. Note that scan operation will not complete until another SCAN signal or **\*TRG** command is input in the final channel state

### Scan operation when the trigger source is set to STEP

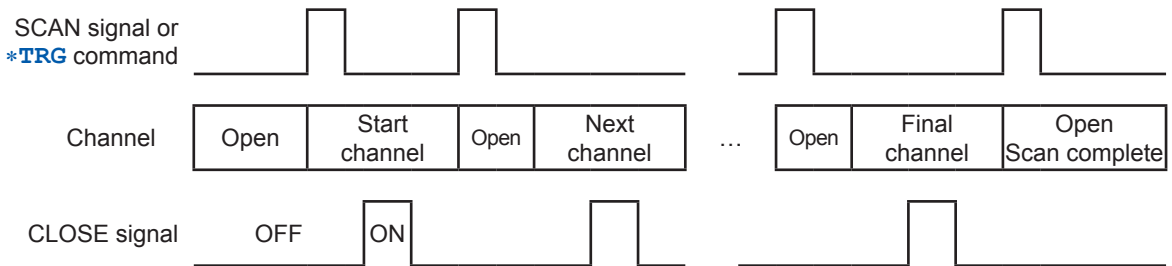

The CLOSE signal is output in pulses. The pulse width can be set using the following command : **IO:PULSe:TIME <0.001 to 0.100/MIN/MAX/DEF>**. (See p.102.)

If the next channel is closed before the CLOSE signal pulse reaches the set pulse width, CLOSE signal pulse will automatically turn off.

| Item  | Communication command   |
|---|---|
| Setting procedure   | <b>*TRG</b> Starts scanning and proceeds along the scan channels.   |
|   | <b>:ABORT</b> Aborts scan operation and returns to the beginning of the scan channel.                               |
| Setting example   | Executes scanning twice from CH1 of <b>SLOT 1</b> to CH22 of <b>SLOT 3</b> .  |
|   | <b>:SCAN 101:322</b>  |
|   | <b>:TRIG:SOUR STEP</b> Advances the scan channel one step at a time using the <b>*TRG</b> command (or SCAN signal). |
|   | <b>*TRG</b> (Repeats for the number of channels.)   |
|   | <b>*TRG</b> Scan operation complete by final channel state  |
|   | Scanning is performed again after completion.   |
|   | <b>*TRG</b> (Repeats for the number of channels.)   |
|   | <b>*TRG</b> Scan operation complete by final channel state  |
|   | Aborts scan operation and restarts from the beginning.  |
|   | <b>:SCAN 101:322</b>  |
| <b>:TRIG:SOUR STEP</b> Advances the scan channel one step at a time using the <b>*TRG</b> command (or SCAN signal). |   |
| <b>*TRG</b> (Repeats.)  |   |
| <b>:ABOR</b> (Aborts scan operation and returns to the beginning of the scan channel.)                              |   |
| <b>*TRG</b> (Repeats for the number of channels from the first channel.)  |   |

All channels are open after scanning is stopped.

The following commands are disabled during scanning.

- Setting the connection method
- Setting the shield switching
- Channel switching
- Setting the channel delay
- Setting the scan list
- Setting concerning the EXT. I/O
- Channel control due to CLOSE command

## 4.5 Resetting Scan Operation

Scanning is reset and stopped by the SCAN\_RESET signal of EXT. I/O or the communication **:ABORT** command. All channel relays are opened and goes back to the beginning of the scan list.

## 4.6 Scan Measurement Example

The following example shows scan measurement with the SW1001 and BT3562 connected using EXT. I/O.

For acquiring measured values, the BT3562 data output function is used.

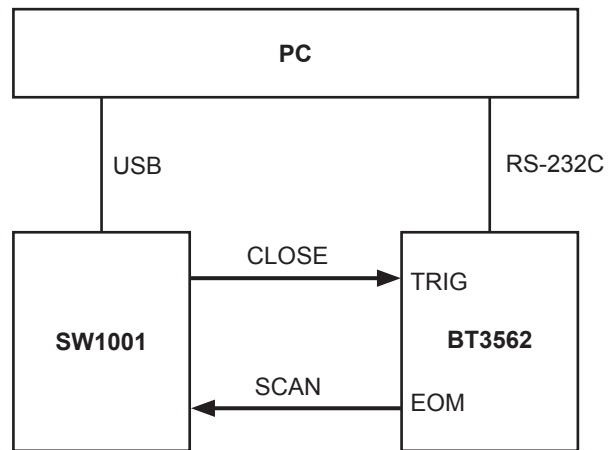
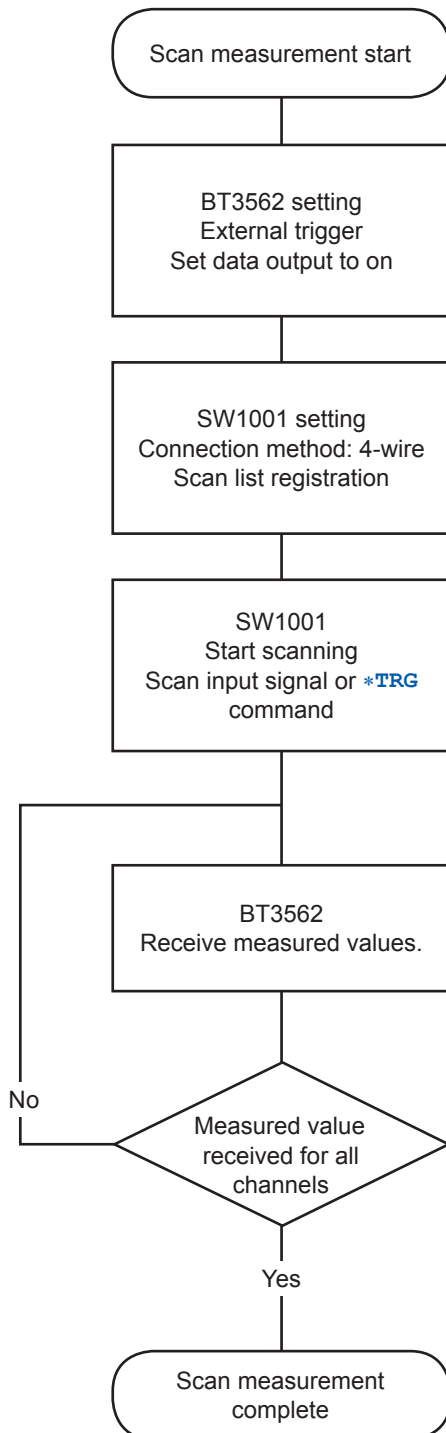

Wiring diagram



# 5 Other Functions

## 5.1 Checking the Device Status

The following items can be checked using the free software for the SW1001 series (downloaded from our website).

- Module information of each slot  
Slot position, model, serial number, and opening/closing frequency of each relay

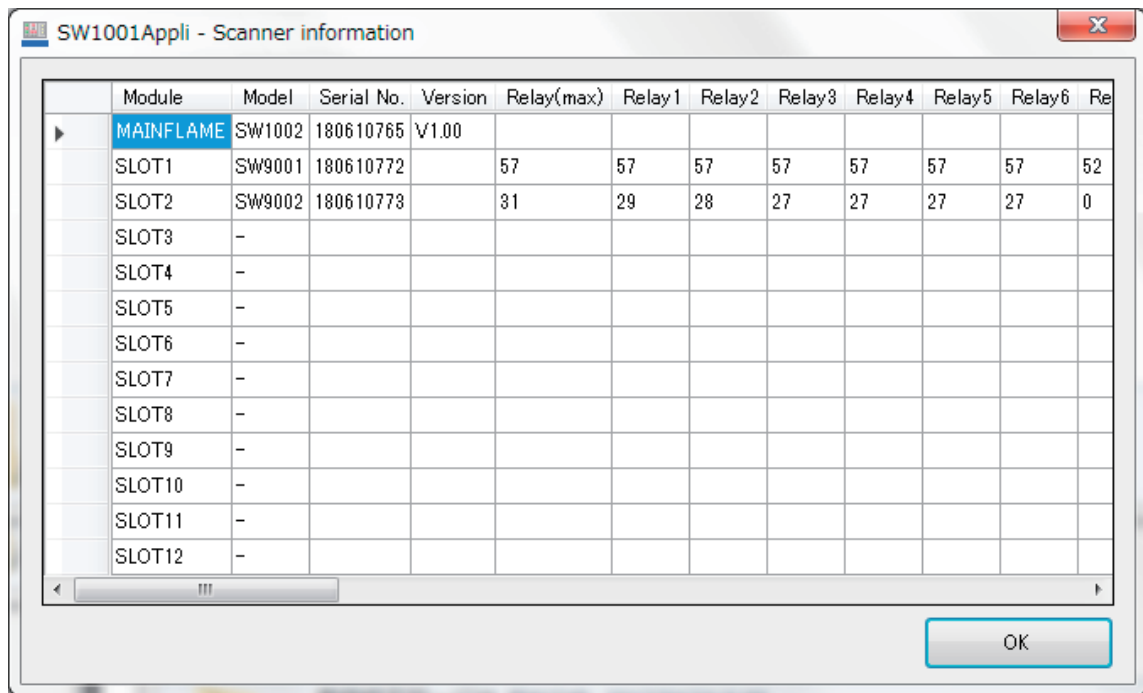

The screenshot shows a software window titled "SW1001Appli - Scanner information". It contains a table with the following data:

|   | Module    | Model  | Serial No. | Version | Relay(max) | Relay 1 | Relay2 | Relay3 | Relay4 | Relay5 | Relay6 | Re |
|---|-----------|--------|------------|---------|------------|---------|--------|--------|--------|--------|--------|----|
| ▶ | MAINFLAME | SW1002 | 180610765  | V1.00   |            |         |        |        |        |        |        |    |
|   | SLOT1     | SW9001 | 180610772  |         | 57         | 57      | 57     | 57     | 57     | 57     | 57     | 52 |
|   | SLOT2     | SW9002 | 180610773  |         | 31         | 29      | 28     | 27     | 27     | 27     | 27     | 0  |
|   | SLOT3     | -      |            |         |            |         |        |        |        |        |        |    |
|   | SLOT4     | -      |            |         |            |         |        |        |        |        |        |    |
|   | SLOT5     | -      |            |         |            |         |        |        |        |        |        |    |
|   | SLOT6     | -      |            |         |            |         |        |        |        |        |        |    |
|   | SLOT7     | -      |            |         |            |         |        |        |        |        |        |    |
|   | SLOT8     | -      |            |         |            |         |        |        |        |        |        |    |
|   | SLOT9     | -      |            |         |            |         |        |        |        |        |        |    |
|   | SLOT10    | -      |            |         |            |         |        |        |        |        |        |    |
|   | SLOT11    | -      |            |         |            |         |        |        |        |        |        |    |
|   | SLOT12    | -      |            |         |            |         |        |        |        |        |        |    |

Use the information as a reference for the relay lifetime.





# 6 Initialization

## 6.1 Initialization Settings

The device is in the initial state at the time of shipment and at the time of initialization using commands. However, communications settings will not be initialized if the initialization is triggered by command.

Settings that are backed up can be stored so that they persist even when the power is turned off by executing the `:SYSTem:BACKup` command.

See: “Backing up settings” (p. 105)

Communications settings are backed up even if the `:SYSTem:BACKup` command is not executed.

✓: Yes, -: No

| Item                               | Initialization description  | Backup         |
|------------------------------------|---|----------------|
| Channel relay                      | All relays open   | -              |
| Bus relay                          | All relays open   | -              |
| EXT. I/O CLOSE output signal       | OFF   | -              |
| Connection method                  | SW9001: 2-wire<br>SW9002: 4-terminal pair   | ✓              |
| Shield switching                   | SW9001: <b>TERMINAL 1</b> , LOW terminal<br>SW9002: <b>TERMINAL 3</b> , sense shield terminal | ✓              |
| Channel delay settings             | 0.0 s   | ✓              |
| Scan list                          | None  | ✓              |
| Scan operation trigger source      | STEP  | ✓              |
| Query forwarding timeout           | 10 s  | ✓              |
| EXT. I/O filter functio            | OFF, 0.05 s   | ✓              |
| Pulse width of CLOSE output signal | 0.005 s   | ✓              |
| Communication settings (USB)       | (No setting item)   | -              |
| Communication settings (RS-232C)   | 9600 bps  | ✓              |
| Communication settings (LAN)       | User setting mode (setting switch: <b>USER</b> )  |                |
|                                    | IP address:   | 192.168.0.254  |
|                                    | Subnet mask:  | 255.255.255.0  |
|                                    | Default gateway:  | 0.0.0.0 (None) |
|                                    | Communication command port number:  | 23             |
|                                    | Fixed setting mode (setting switch: <b>DFLT</b> )   |                |
| IP address:                        | 192.168.0.254   |                |
| Subnet mask:                       | 255.255.255.0   |                |
| Default gateway:                   | 0.0.0.0 (None)  |                |
| Communication command port number: | 23  |                |



# 7 External Control (EXT. I/O)

Thoroughly read “Before starting the external control” (p.6) beforehand.

Connecting the instrument and the EXT. I/O terminal allows you to perform measurement in synchronization with channel switching when using the scan function. Also scan control can be performed from the PLC and other devices.

All signals are isolated from the switching circuit, communication circuit, and ground (earth) (the common terminal for I/O is shared).

The input circuit can be switched so that it can support sinking current output (NPN) or sourcing current output (PNP).

Check the input/output rating and internal circuit configuration, and then understand the safety precautions. After that, connect the instrument or control system and use it in a correct manner.

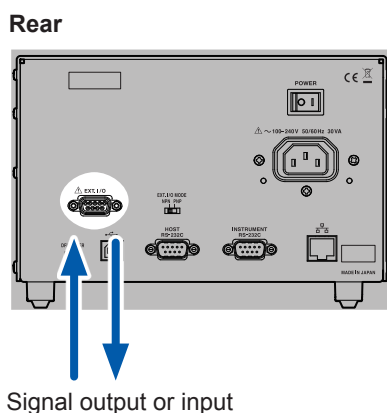

## 7.1 External Control Flow

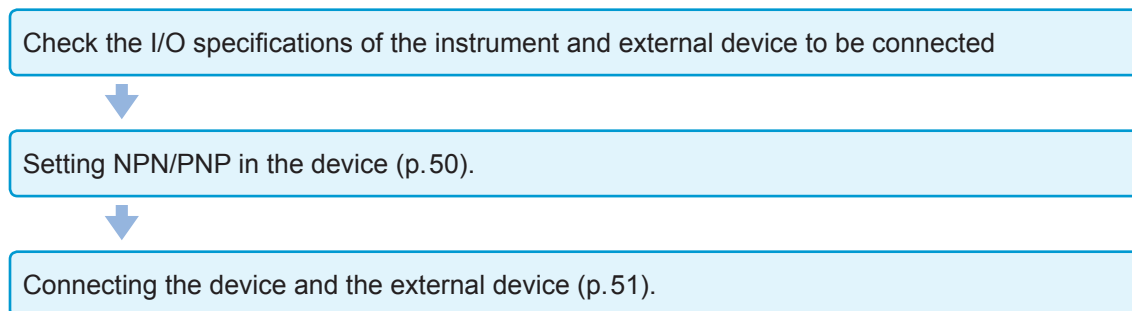

## 7.2 Switching between Sinking Current (NPN) and Sourcing Current (PNP)

Thoroughly read “Before starting the external control” (p.6) beforehand.

The applicable PLC type can be changed using the **EXT. I/O MODE** change-over switch. It is set to NPN at the time of shipment.

|                       | EXT. I/O MODE change-over switch settings |                           |
|-----------------------|---|---------------------------|
|                       | NPN                                       | PNP                       |
| Device input circuit  | Supports sinking output.                  | Supports sourcing output. |
| Device output circuit | Non-polar                                 | Non-polar                 |
| ISO_5 V output        | +5 V output                               | -5 V output               |

Rear

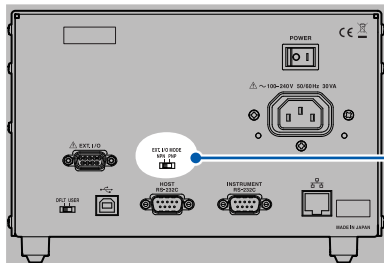

EXT. I/O MODE

NPN PNP



Left: Sinking current (NPN)  
Right: Sourcing current (PNP)

# 7.3 Connection

## Device connector and compatible connectors

Thoroughly read “Before starting the external control” (p.6) beforehand.

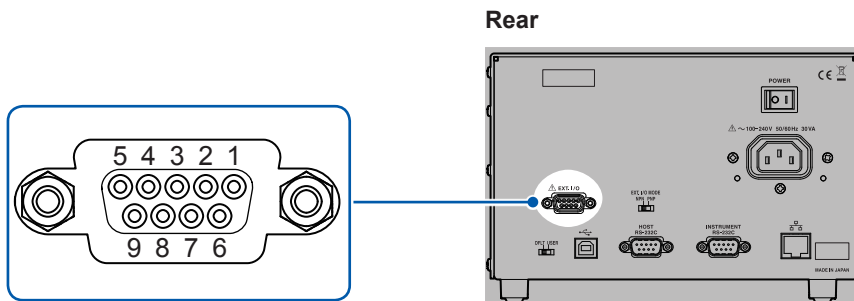

### Connectors used (device unit side)

- D-SUB 9-pin  
Female #4-40 inch screw

### Compatible connectors

- DE-9P-ULR (solder type)
- DESP-JB9PR (crimping type)

Manufactured by Japan Aviation Electronics Industry, Limited

The connector frame is connected to the casing (metal) of the device as well as the protective ground terminal of the power inlet (conductive). Be aware that it is not isolated from the ground.

| Pin | Signal name | I/O | Function                                 | Logic |
|-----|-------------|-----|--|-------|
| 1   | SCAN        | IN  | Scan start/advance                       | Edge  |
| 2   | (Reserved)  | IN  | —  | —     |
| 3   | ISO_5V      | —   | Isolated power supply +5 V (-5 V) output | —     |
| 4   | CLOSE       | OUT | Channel closing complete                 | Pulse |
| 5   | (Reserved)  | OUT | —  | —     |
| 6   | SCAN_RESET  | IN  | Resets scan operation.                   | Edge  |
| 7   | (Reserved)  | IN  | —  | —     |
| 8   | ISO_COM     | —   | Isolated power supply common             | —     |
| 9   | (Reserved)  | OUT | —  | —     |

# 7

External Control (EXT. I/O)

## Signal Functions

### Isolated power supply output

| Pin | Signal name | EXT. I/O MODE change-over switch settings |                                   |
|-----|-------------|---|-----------------------------------|
|     |             | NPN                                       | PNP                               |
| 3   | ISO_5V      | Isolated power supply +5 V                | Isolated power supply -5 V output |
| 8   | ISO_COM     | Isolated power supply common              | Isolated power supply common      |

### Input signal

| Signal name | Description  | Reference |
|-------------|--|-----------|
| SCAN        | Starts scan operation.<br>Moves forward to the next channel during scan operation.<br>This signal is not valid when switching channels (until the CLOSE signal is output). | p.41      |
| SCAN_RESET  | Resets scan operation and stops scanning.<br>All channel relays are opened.  | p.42      |

### Output signal

| Signal name | Description  | Reference |
|-------------|--|-----------|
| CLOSE       | Outputs a pulse signal with the set pulse width when the channel relay is closed.<br>The signal will turn off when the set pulse width time elapses or when the channel relay opens. | p.31      |

## Connection to the instrument

An example of connecting the device and instrument for scan measurement is shown below.  
Example: Connecting the BT3562 Battery HiTester  
Set the BT3562 to the external trigger mode.

### SW1001 (SW1002)

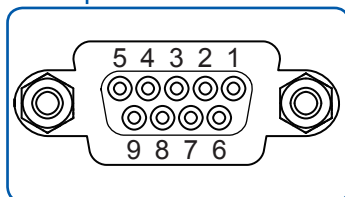
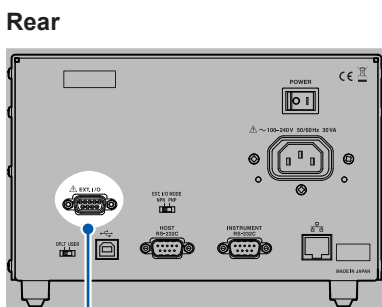

- 4: CLOSE — 1: TRIG
- 1: SCAN — 28: EOM
- 8: ISO\_COM — 27: ISO\_COM

### BT3562

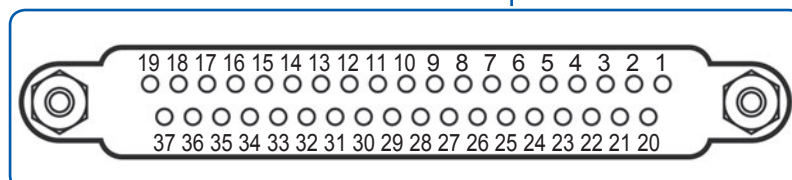
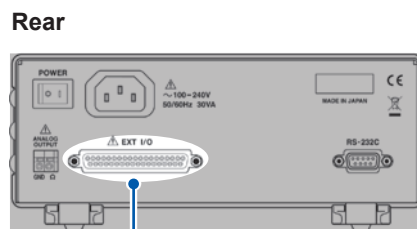

## 7.4 Timing Chart

The level of each signal shows the contact on/off status.

In the sourcing current (PNP) setting, HIGH and LOW in the timing chart are the same as the voltage level of the **EXT. I/O** terminal. HIGH and LOW are reversed for the voltage level in the sinking current (NPN) setting.

### Channel switching operation and scan operation reset

#### (1) Channel switching operation

The scan input signal starts scanning and advances the scan channel.

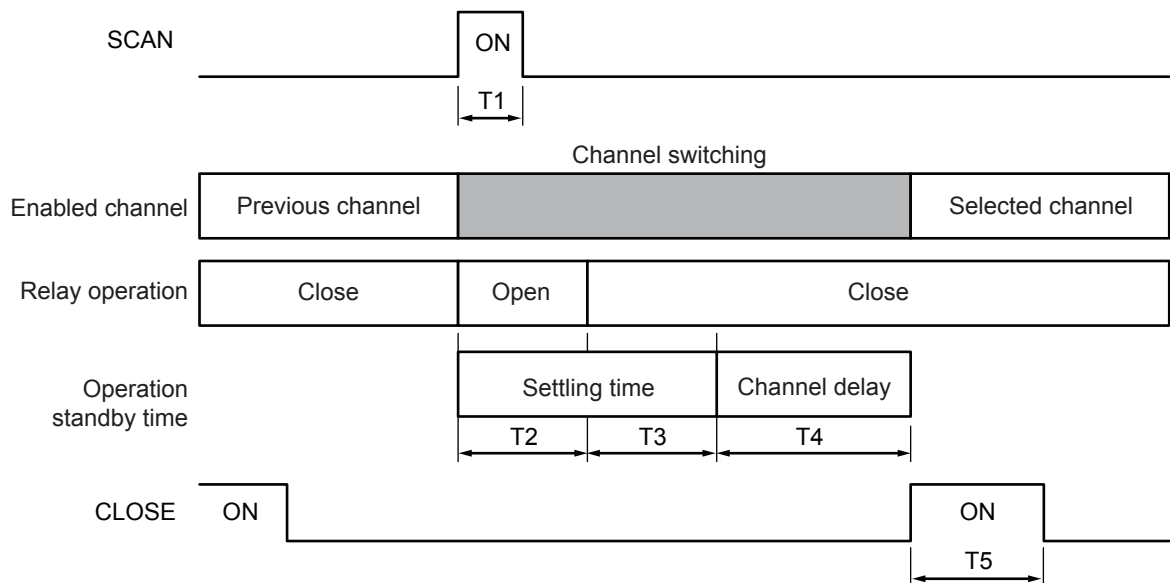

If the next channel is closed before the CLOSE signal pulse reaches the set pulse width, CLOSE signal pulse will automatically turn off.

The SCAN input signal is not valid while switching channels (until the CLOSE signal is output).



**(2) Scan operation reset**

When the SCAN\_RESET signal is input during scan operation, the scan operation is stopped and the channel relay is opened. When the scan signal is input with the scan operation reset, the scan operation is restarted from the beginning.

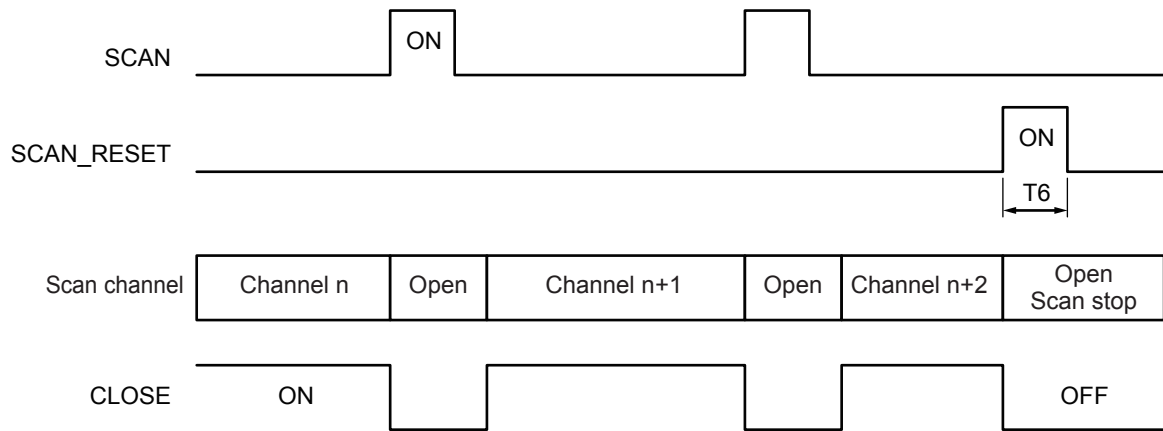

| Item | Description                             | Time  |
|------|---|---|
| T1   | SCAN signal pulse width                 | 1 ms or longer  |
| T2   | Relay settling time (when it is opened) | SW9001: 5 ms, SW9002: 5 ms                                  |
| T3   | Relay settling time (when it is closed) | SW9001: 5 ms, SW9002: 5 ms                                  |
| T4   | Channel delay time (user setting)       | 0 ms to 9999 ms (based on the setting)                      |
| T5   | CLOSE signal pulse width                | 1 ms to 100 ms<br>As per the :IO:PULSe:TIME command setting |
| T6   | SCAN_RESET signal pulse width           | 1 ms or longer  |

## 7.5 Internal Circuit Configuratio

### NPN setting

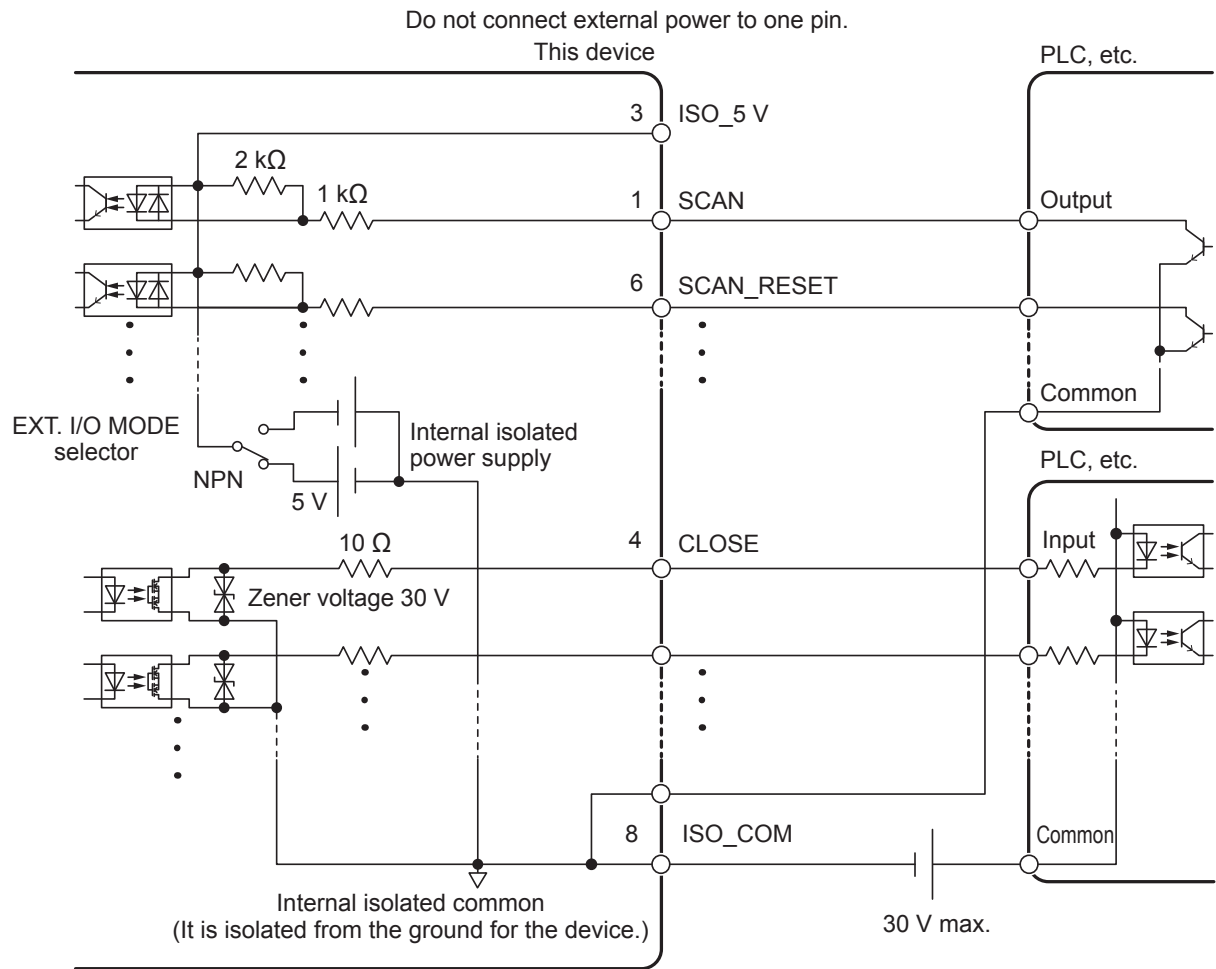

### PNP setting

Use ISO\_COM for the common terminal for both the input and output signals.

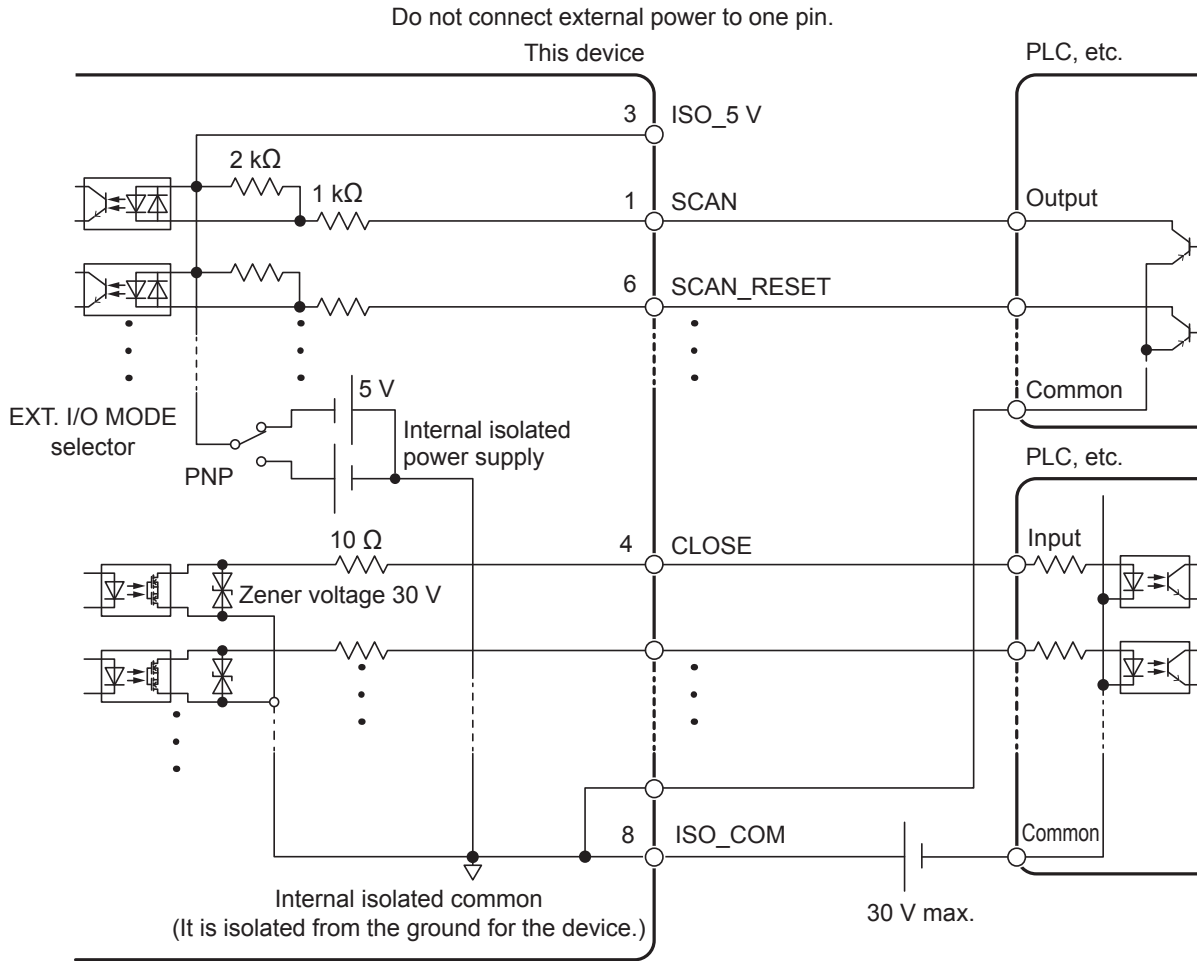

### Electrical specification

|                                       |                             |   |
|---------------------------------------|-----------------------------|---|
| <b>Input signal</b>                   | Input format                | Isolated non-voltage contact input using a photocoupler (Compatible with sinking/sourcing current output) |
|                                       | Input ON                    | Residual voltage 1 V (input ON current 4 mA (reference value))  |
|                                       | Input OFF                   | OPEN (interrupting current 100 $\mu$ A or less)   |
| <b>Output signal</b>                  | Output format               | Isolated open drain output using a photocoupler (non-polar)   |
|                                       | Maximum load voltage        | 30 V DC max.  |
|                                       | Maximum output current      | 50 mA/channel   |
|                                       | Residual voltage            | 1 V or less (load current 50 mA)/0.5 V or less (load current 10 mA)                                       |
| <b>Internal isolated power supply</b> | Output voltage              | Sinking output compatible: +4.2 V to +5.8 V<br>Sourcing output compatible: -4.2 V to -5.8 V               |
|                                       | Maximum output current      | 100 mA  |
|                                       | External power supply input | None  |
|                                       | Insulation                  | Floating from the protective grounded potential and the measurement circuit                               |
|                                       | Insulation rating           | Voltage between the module and ground: 50 V DC, 30 V AC rms, 42.4 V AC peak or less                       |

## Connection examples

### Input circuit connection examples

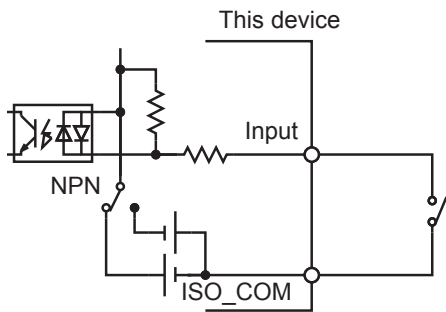

Connection to the switch

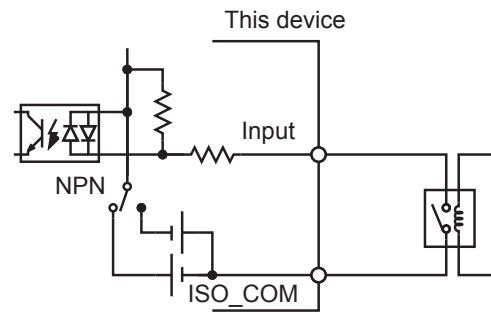

Connection to the relay

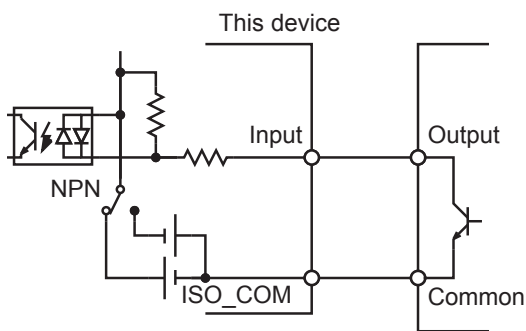

Connection to the PLC output (NPN output)

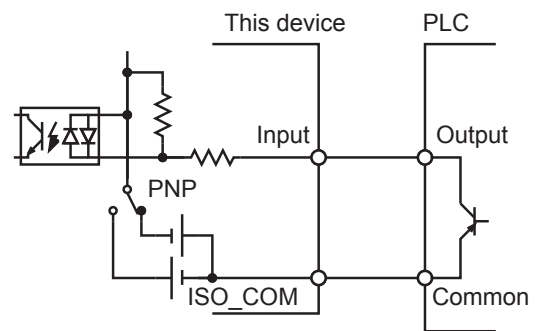

Connection to the PLC output (PNP output)

## Output circuit connection examples

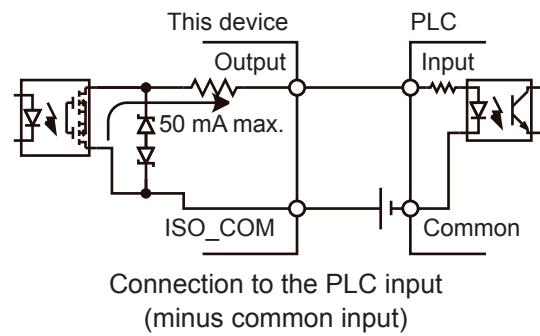
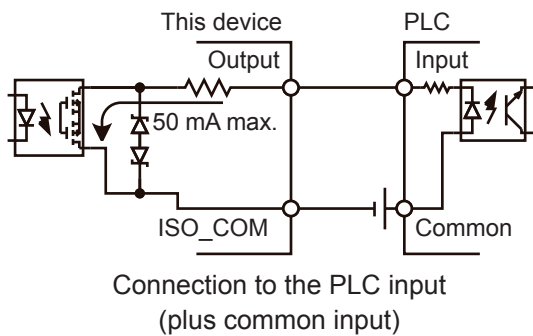
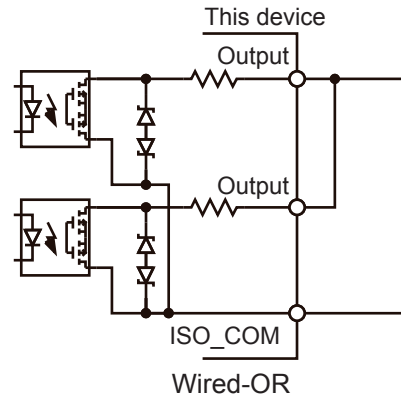
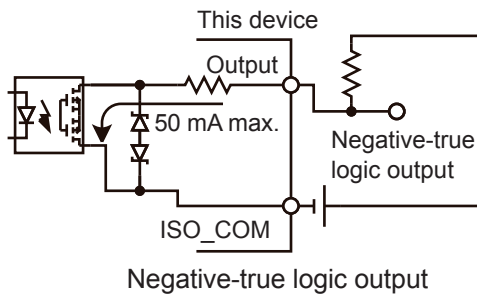
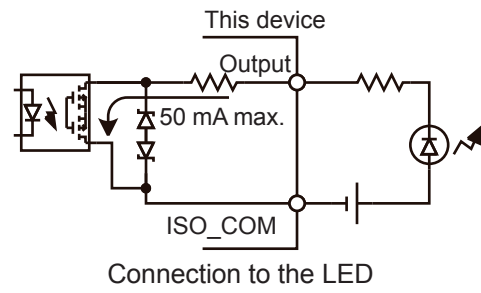
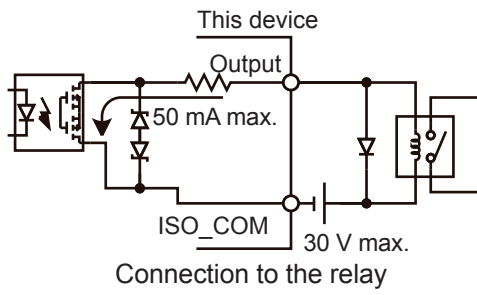

## 8.1 Interface Overview and Features

The device can be controlled using the LAN interface, USB interface, or RS-232-C interface. All of the interfaces can be used and do not need to be specified. To avoid malfunction, however, use only one interface for control.

For the specifications, see "9.4 SW1001, SW1002 Interface Specifications" (p. 123)

## 8.2 Setting the Communication Setting Mode

The communication setting mode needs to be specified before using the communication function. Communication settings can be specified for each interface to be used, however, the communication setting mode should be selected if the present communication settings are unknown.

|                                    |  |
|------------------------------------|--|
| Fixed setting mode ( <b>DFLT</b> ) | Communications are performed using the specified communication settings.     |
| User setting mode ( <b>USER</b> )  | Communications are performed with the user-specified communication settings. |

The device is in the fixed setting mode at the time of shipment. Refer to "2.6 Setting the Communication Setting Mode" (p.22) to set the communication setting mode.

Specify communication settings according to the interface to be used.

See:

"8.3 LAN Interface" (p.60)

"8.4 USB Interface" (p.64)

"8.5 RS-232C Interface" (p.66)

## 8.3 LAN Interface

This device is equipped with an Ethernet 100BASE-TX interface as standard. The device is connected to the network using a LAN cable (up to 100 m) compatible with 10BASE-T or 100BASE-TX, and then the device can be controlled using the PC.

### Networking the device and PC

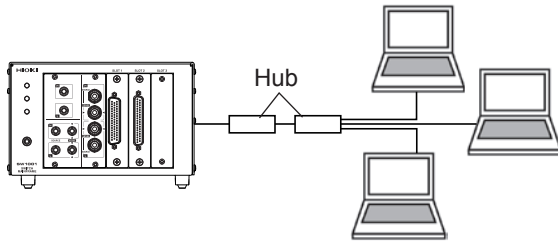

### Perform one-to-one connection

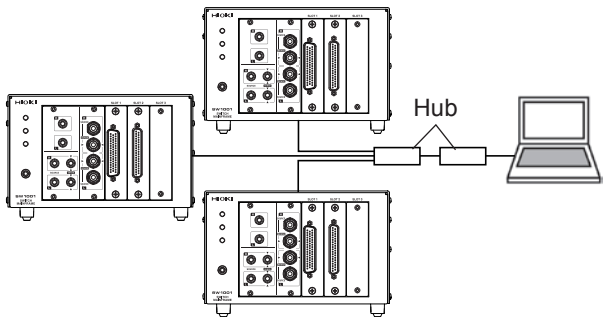
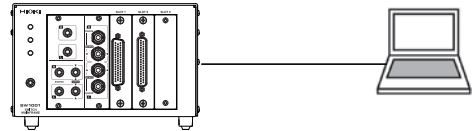

When a program is created and the device is connected to the communication command port via TCP, the device can be controlled using communication commands.

### Flow of preparations

Set the communication conditions of the device (p.61).



Connect the LAN cable (p.63).

## Communication condition settings

### To be checked before setting

The settings are different when the device and external device are connected to the existing network and when the device and a PC are connected to a new network.

#### Connecting the device to the existing network

The network administrator (department) needs to assign the following items in advance. Be sure to assign them so that they do not overlap with other devices.

|   |                              |
|---|------------------------------|
| • Address settings of the device  |                              |
| IP address: .....   | ____.____.____.____          |
| Subnet mask: .....  | ____.____.____.____          |
| • Gateway   |                              |
| Whether or not to use a gateway: .....                                  | Use / Not use                |
| IP address (if used): .....   | ____.____.____.____          |
|   | (Set to 0.0.0.0 if not used) |
| • Communication command port No. to be used: ____ (Default setting: 23) |                              |

#### Creating a new network using the device and a PC

(Using a local network that is not connected externally)

The addresses shown below are recommended if there is no administrator or you are responsible for setting.

Setting example:

|                                    |   |
|------------------------------------|---|
| IP address                         | Set sequential IP addresses as shown below. |
| PC:                                | 192.168.0.1                                 |
| First device:                      | 192.168.0.2                                 |
| Second device:                     | 192.168.0.3                                 |
| Third device:                      | 192.168.0.4                                 |
|                                    | ↓   |
| Subnet mask:                       | 255.255.255.0                               |
| Gateway:                           | OFF   |
| Communication command port number: | 23  |



## Setting LAN communications

Set the commands shown below for the LAN communications.

```

:SYSTem:COMMunicate:LAN:IPAdDress <Value 1>,<Value 2>,<Value 3>,<Value 4>
Set the IP address for the device.

:SYSTem:COMMunicate:LAN:SMASK <Value 1>,<Value 2>,<Value 3>,<Value 4>
Set the LAN subnet mask.

:SYSTem:COMMunicate:LAN:GATeway <Value 1>,<Value 2>,<Value 3>,<Value 4>
Set the address for the default gateway.

:SYSTem:COMMunicate:LAN:CONTRol <1 - 9999>
Specify the communication command port No.

:SYSTem:COMMunicate:LAN:UPDate
Update and apply the LAN settings.
    
```

When the communication setting mode switch (**DFLT/USER**) is set to **DFLT**, the default settings are used regardless of the settings specified here

Reference: "2.6 Setting the Communication Setting Mode" (p.22)

### Setting items

|                                       |   |
|---------------------------------------|---|
| <b>IP address</b>                     | An address to identify individual instruments that are connected on the network. Be sure to set an address that does not overlap with other devices.  |
| <b>Subnet mask</b>                    | This setting divides the IP address into the address part showing the network and the address part showing the device. Be sure to set a subnet mask that matches the subnets of other devices within the same network.  |
| <b>Gateway IP address</b>             | <p><b>For network connection</b></p> <p>When the communication PC and the device are in different networks, specify the IP address of the device that becomes a gateway.</p> <p>If the PC is in the same network, set a gateway address that is the same as the default gateway in the general PC settings.</p> <p><b>For one-to-one connection between the device and PC or when no gateway is used</b></p> <p>Set the IP address to <b>0.0.0.0</b>.</p> |
| <b>Communication command port No.</b> | Specify the TCP/IP port No. used for connecting communication commands.   |

## Connecting the LAN cable

Thoroughly read "Before connecting the communications cables" (p.6) beforehand.  
Connect a LAN cable to the LAN connector of the device.

Recommended cable: Model 9642 LAN cable (optional), 100BASE-TX or 10BASE-T compatible LAN cable (up to 100 m, straight cable and cross cable can be used)

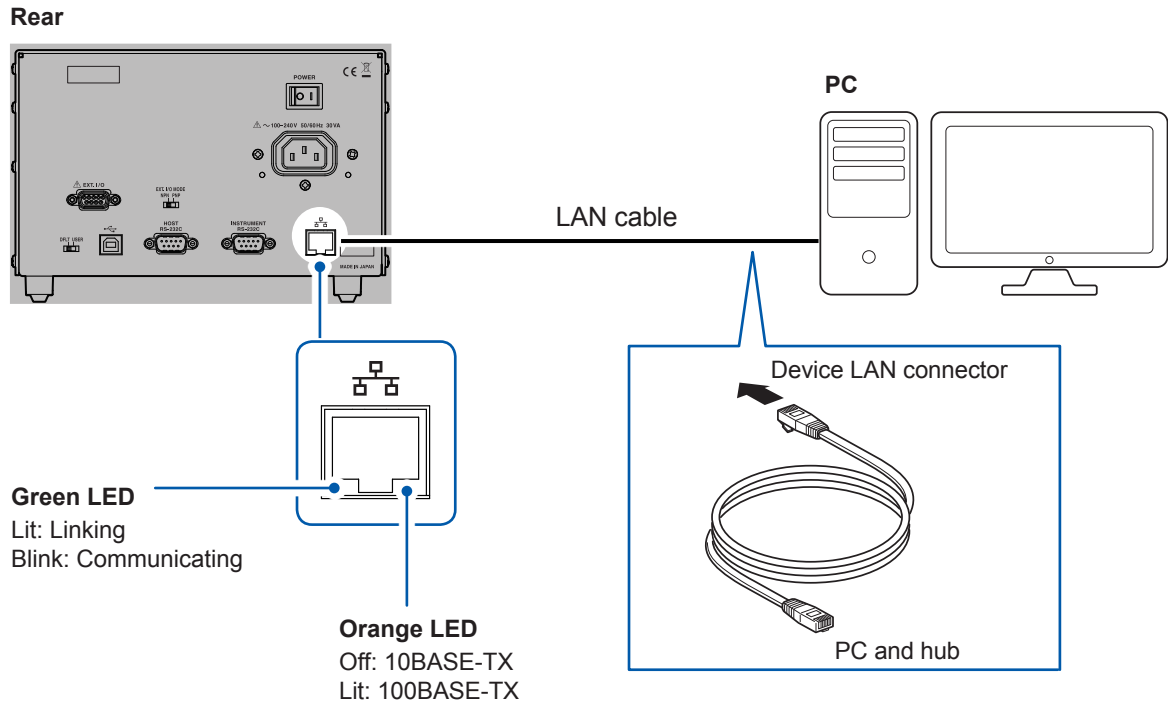

If the green LED on the LAN connector is not lit even after the device has been connected to the LAN, the device or connection device may be malfunctioning or the LAN cable may have a broken wire.

## 8.4 USB Interface

### Installing the USB driver

When the device is connected to a PC for the first time, the dedicated USB driver is required. If the driver is already installed, the following procedure is not required. The USB driver is on the provided CD. It can also be downloaded from our website.

#### Installation procedure

Before connecting the device and PC using a USB cable, install the USB driver. If a USB cable is already connected to the device and PC, remove the USB cable.

- 1** Log into the PC using an account with administrative privileges such as “administrator”.
- 2** Exit all applications running on the PC.
- 3** Open [X:\driver] on the provided CD and execute [HiokiUsbCdcDriver.msi] (driver installer) (X: is a CD-ROM drive).

Follow the instructions that appear on the screen to continue the installation. Wait for a dialog box as it may take some time depending on the operation environment.

- 4** Connect the device and PC using the LAN cable after the installation is completed.

The device should now be recognized.

- If the Found New Hardware Wizard screen for new hardware is displayed, select [No, not this time] and then select [Install the software automatically (Recommended)] for checking the connection to Windows Update.
- Even when a device with a different serial No. is connected, you may receive notification of the installation of a new device. Follow the instructions on the screen and install the USB driver.
- A warning message is displayed since the Windows® logo has not been acquired. Ignore the message and continue the installation procedure.

#### Uninstallation procedure

Uninstall the USB driver when it is no longer required.

Click [Control Panel] - [Uninstall a program], and then delete [HIOKI USB CDC Driver].

## Connecting the USB cable

Thoroughly read "Before connecting the communications cables" (p.6) beforehand.  
Recommended cable: Hioki model L1002 USB Cable (A-B)

### Rear

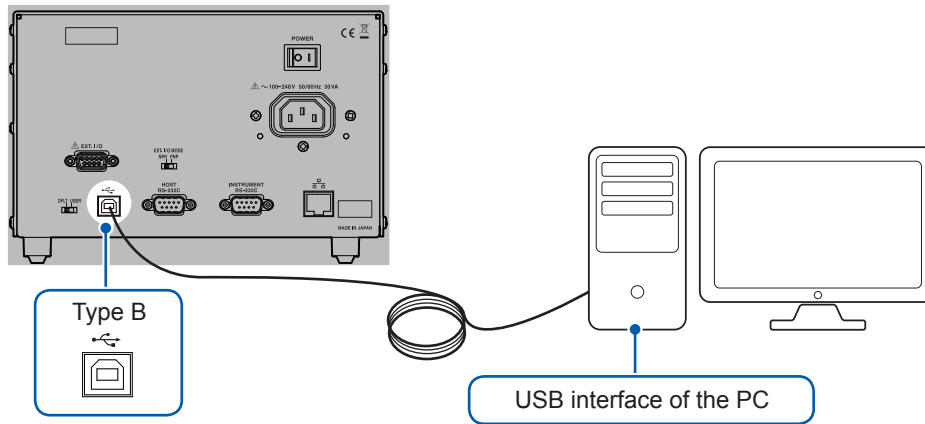

# 8.5 RS-232C Interface

## Connecting the RS-232C cable

Thoroughly read "Before connecting the communications cables" (p.6) beforehand.

Connect the RS-232 cable to the **HOST RS-232C** connector. Be sure to tighten the screws when connecting the cable.

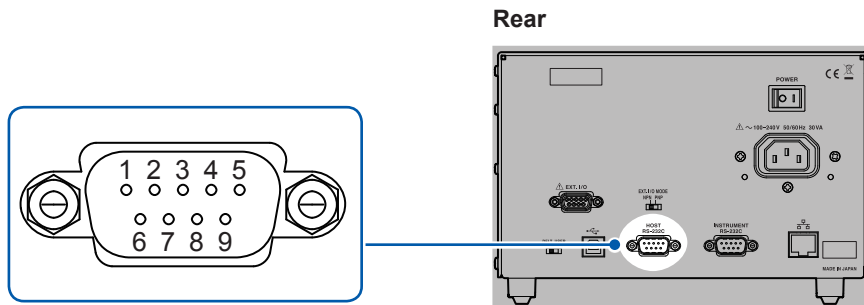

### Connectors used (device unit side)

- D-sub 9-pin contact
- Terminal block screw #4-40

The I/O connector is DTE. The device uses pin No. 2, 3, and 5. Other pins are not used.

| Pin No. | Signal name |     |     | Signal              | Remarks                      |
|---------|-------------|-----|-----|---------------------|------------------------------|
|         | Common      | EIA | JIS |                     |                              |
| 1       | DCD         | CF  | CD  | Data Carrier Detect | Not connected                |
| 2       | RxD         | BB  | RD  | Receive Data        |                              |
| 3       | TxD         | BA  | SD  | Transmit Data       |                              |
| 4       | DTR         | CD  | ER  | Data Terminal Ready | ON level (+5 V to +9 V) fixe |
| 5       | GND         | AB  | SG  | Signal Ground       |                              |
| 6       | DSR         | CC  | DR  | Data Set Ready      | Not connected                |
| 7       | RTS         | CA  | RS  | Request to Send     | ON level (+5 V to +9 V) fixe |
| 8       | CTS         | CB  | CS  | Clear to Send       | Not connected                |
| 9       | RI          | CE  | CI  | Ring Indicator      | Not connected                |

## Connecting the device and PC

Use a D-sub 9-pin female/female crossover cable.

Connect the **HOST RS-232C** connector of the device and the COM port of the PC.

Recommended cable: Hioki model 9637 RS-232C cable (9pin-9pin/1.8 m)

### Cross connections

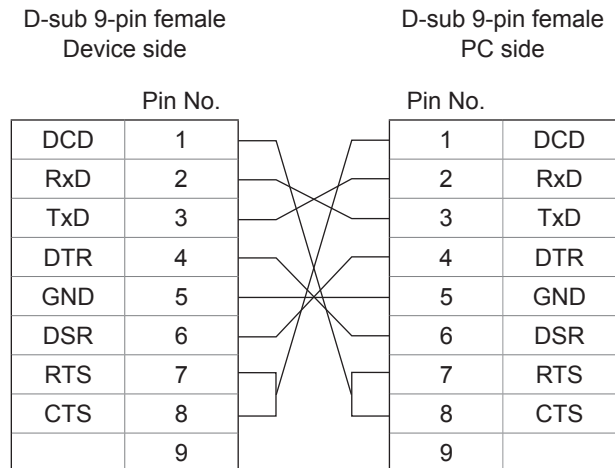

## Setting RS-232C communications

Set the commands shown below for the transmission speed.

```
:SYSTem:COMMunicate:RS232C:SPEED <9600/19200/38400>
```

The speed can be selected from 9600 bps, 19200 bps, or 38400 bps.

The speed setting is immediately changed.

Other RS-232C communication parameters are fixed to 8 for data bit length, 1 for stop bit, none for parity check, and none for flow control

When the communication setting mode switch (**DFLT/USER**) is set to **DFLT**, the speed setting is fixed to 9600 bps regardless of the settings specified her

See: "2.6 Setting the Communication Setting Mode" (p.22)

## Setting the controller (PC, PLC, etc.)

Be sure to set the controller as follows.

|   |   |
|---|---|
| Asynchronous (Start-stop) transmission system |   |
| Transmission speed                            | 9600 bps/19200 bps/38400 bps<br>(Set the speed based on the device settings.) |
| Data bit length                               | 8   |
| Stop bit                                      | 1   |
| Parity check                                  | None  |
| Flow control                                  | None  |
| Protocol                                      | Non-procedure   |

### IMPORTANT

Communications may not be established at the high transmission speed (baud rate) depending on the PC. Lower the transmission speed in that case.

## 8.6 Communication Command Forwarding Function

The communication command forwarding function forwards commands sent from the host to the communication interface (RS-232C) of the instrument without making any change.

- It is possible to control both the device and instrument using one communication port.
- Commands are sent to the instrument in synchronization with the completion of channel switching operation.

Data received from the instrument can also be forwarded in addition to sent data.

|  |  |
|--|--|
| Number of devices to which data can be forwarded | 1  |
| Forwarding method                                | <p>After the forward command <b>“:A”</b>, add a transmit character string as a parameter.</p> <p>(use double quotation marks for the transmit character string.)</p> <p>Example: <b>*RST</b> is sent to the instrument.</p> <pre><b>:A " *RST "</b></pre> <p>Or <b>“:A”</b> can also be added to the start of the transmit character string. (In this case, do not insert a space after <b>“:A”</b>)</p> <p>Example: <b>*RST</b> is sent to the instrument.</p> <pre><b>:A *RST</b></pre> <p>Example: <b>FUNC RV</b> is sent to the instrument.</p> <pre><b>:A FUNC RV</b></pre> |
| Receiving method                                 | <p>Specify a query by adding <b>“?”</b> to the forward command’s <b>“:A”</b> string. (use double quotation marks for the transmit character string.)</p> <p>Example: Send the query <b>:READ?</b> to the instrument and receive a response.</p> <pre><b>:A " :READ? "</b></pre> <p>Or <b>“:A”</b> can also be added to the start of the query character string.</p> <p>Example: Send the query <b>:READ?</b> to the instrument and receive a response.</p> <pre><b>:A :READ?</b></pre>   |

Commands to the device and to the instrument can be mixed.

|          |   |
|----------|---|
| Example: | <p>With CH101 selected, the query <b>:READ?</b> is sent to the instrument and the measured value is received.</p> <pre><b>CLOSE 101</b></pre> <pre><b>:A " :READ? "</b></pre> |
|----------|---|

After the last command execution of the device is completed, command (or query) forward to the instrument is executed.

When the power is turned on, the first data received from the instrument using this function may include undefined values at the beginning (for example, undefined data accompanying the activation of the instrument’s power supply).

Before receiving data for the first time, send the **:A\*IDN?** query and receive the response in order to clear the device’s receive buffer.

Transferring is done by row unit and buffer is approx. 128 byte of both sending and receiving. Binary data is incompatible.



## Connection method

When using the communication command forwarding function, connect the **INSTRUMENT RS-232C** connector of the device and the **RS-232C** connector of the instrument.

### SW1001 (SW1002)

Rear

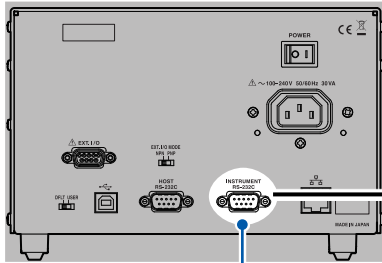

**INSTRUMENT  
RS-232C** connector

### Instrument

Rear

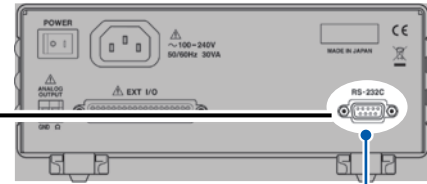

**RS-232C** connector

Use the RS-232C cross cable.

Set the communication speed of the instrument based on the communication speed setting of the device.

## Setting the transmission speed

Set the commands shown below for the transmission speed of the communication command forwarding function.

```
:SYSTEM:COMMunicate:FORWARD:RS232C:SPEED <9600/19200/38400>
```

The speed can be selected from 9600 bps, 19200 bps, or 38400 bps.

The speed setting is immediately changed.

Other RS-232C communication parameters are fixed to 8 for data bit length, 1 for stop bit, None for parity check, and None for flow control

See: "2.6 Setting the Communication Setting Mode" (p.22)

## Setting the receive timeout

You can set the timeout time to use when receiving data from the instrument by means of the communication command forwarding function.

Sending a query to the instrument will result in a timeout error if the set timeout time elapses before a response is received from the instrument.

Timeout can be set by the command below.

```
:SYSTEM:COMMunicate:FORWARD:TIMEout <Time>
```

Time: Timeout time (s)

# 8.7 Communication Method

Various messages are supported for controlling the device through the interfaces. Messages can be either program messages, sent from the PC to the device, or response messages, sent from the device to the PC.

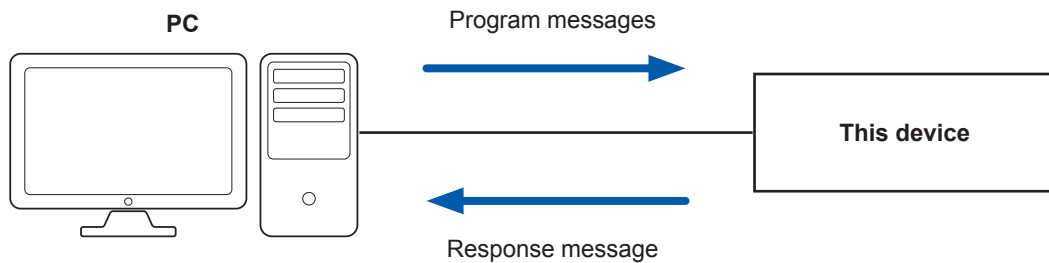

Message types are further categorized as follows.

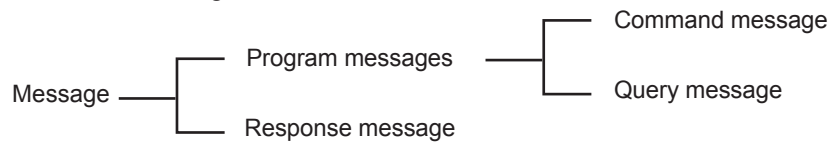

## Message format

### Program messages

Program messages can be either command messages or query messages.

#### (1) Command messages

Instructions to control the instrument, such as to change or reset the instrument settings.

Example: Instruction to set the range

```

:ROUT:CLOSE 101
  
```

↑
↑
↑  
Header portion    Space    Data format

#### (2) Query messages

Requests for responses relating to results of operation or measurement, or the state of device settings

Example: Request for the present measurement range

```

:ROUT:CLOSE?
  
```

↑
↑  
Header portion    Question mark

See: "Headers" (p.72), "Separators" (p.73), and "Data formats" (p.74)

## Response messages

When a query message is received, its syntax is checked and a response message is generated. If an error occurs when a query message is received, no response message is generated for that query.

## Command syntax

Command names are chosen to mnemonically represent their function and can be abbreviated. The full command name is called the “long form”, and the abbreviated name is called the “short form”.

The command references in this manual indicate the short form in uppercase letters, extended to the long form in lowercase letters, although the commands are not case-sensitive in actual usage.

|                                   |                                |
|-----------------------------------|--------------------------------|
| <code>:SYSTem:MODUle:DELay</code> | Expression used in this manual |
| <code>:SYSTEM:MODULE:DELAY</code> | OK (long form)                 |
| <code>:SYST:MOD:DEL 0.01</code>   | OK (short form)                |
| <code>:SYST:MOD:DELA 0.01</code>  | Error                          |
| <code>:SYST:MOD:DE 0.01</code>    | Error                          |

Response messages generated by the device are in long form and in uppercase letters.

## Headers

Headers must always be prefixed to program messages

### (1) Command program headers

The following three types are available.

| Command type                  | Example                     | Description   |
|-------------------------------|-----------------------------|---|
| Headers for simple commands   | <code>*ESE 0</code>         | This header type is a sequence of letters and digits.   |
| Headers for compound commands | <code>:SYSTem:PRESet</code> | These headers consist of multiple simple command type headers separated by colons (:).                        |
| Headers for standard commands | <code>*RST</code>           | This header type begins with an asterisk (*), indicating that it is a standard command defined by IEEE 488.2. |

### (2) Query program headers

These commands are used to interrogate the instrument about the results of operations, measured values, and the present states of instrument settings. As shown by the following examples, when a query is formed by appending a question mark (?) after a program header, it is recognized as a query.

|                             |
|-----------------------------|
| Example: <code>*STB?</code> |
| <code>:SYSTem:ERRor?</code> |

## Message terminators

This device recognizes the following message terminators (delimiters).

|         |           |
|---------|-----------|
| RS-232C | CR, CR+LF |
| LAN     | CR, CR+LF |

Depending on the interface settings, the following can be selected as the terminator for response messages.

|         |       |
|---------|-------|
| RS-232C | CR+LF |
| LAN     | CR+LF |

Reference: "Communication condition settings" (p.61)

## Separators

### (1) Command program headers

Multiple messages can be written in one line by separating them with semicolons (;).

Example: `:ROUT:CLOSE 101; *OPC?`

↑  
Semicolon

- When messages are combined in this way and if one command contains an error, all subsequent messages up to the next terminator will be ignored.
- A query error occurs if a query command is combined with an immediately following semicolon (;) and subsequent command.

### (2) Header separator

In a message consisting of both a header and data, the header is separated from the data by a space.

Example: `:SCAN:ADD 101`

↑  
Space

### (3) Data separator

In a message containing multiple data items, commas (,) are required to separate the data items from one another.

Example: `:SYST:MOD:WIRE:MODE 1,WIRE2`

↑  
Comma

## Data formats

The device uses character data and decimal numeric data depending on the command.

### (1) Character data

Character data always begins with an alphabetic character, and subsequent characters may be either alphabetic or numeric. Character data is not case-sensitive, although response messages from the device are only upper case.

Like command syntax, the data can be in long or short form and can be received in either form.

Example: `:SYSTEM:MODULE:WIRE:MODE 1 WIRE2`

### (2) Decimal numeric data

Three formats are used for numeric data, identified as NR1, NR2, and NR3. Numeric values may be signed or unsigned. Unsigned numeric values are handled as positive values.

Values exceeding the precision handled by the device are rounded to the nearest valid digit.

- NR1 integer data (example: +12, -23, 34)
- NR2 fixed-point data (example: +1.23, -23.45, 3.456)
- NR3 floating-point exponential representation data (example: +1.0E-2, -2.3E+4)

The term “NRf format” includes all three of the above numeric decimal formats.

The device accepts NRf format data.

The format of response data is specified for each command, and the data is sent in that format

Example: `:STAT:QUES:ENAB 106`  
`:IO:PULSE:TIME 0.001`

## Compound command header omission

For several commands having a common header are combined to form a compound command, if they are written together in sequence, the common portion can be omitted after its initial occurrence.

This common portion is called the “current path” (analogous to the path concept in computer file storage), and until it is cleared, the interpretation of subsequent commands presumes that they share the same common portion.

This usage of the current path is shown in the following example:

|  |
|--|
| <p>Full expression</p> <pre>:SYSTem:MODUle:WIRE:MODE 1,WIRE2;:SYSTem:MODUle:WIRE:MODE 2,WIRE2</pre>  |
| <p>Compacted expression</p> <pre>:SYSTem:MODUle:WIRE:MODE 1,WIRE2;MODE 2,WIRE2</pre> <p>↑</p> <p>This portion becomes the current path and can be omitted from the messages immediately following.</p> |

The current path is cleared in the following circumstances.

- When the power is turned on
- Key reset
- A colon (:) is entered at the start of the command.
- Message terminator detection

Standard command messages can be executed regardless of the current path. They have no effect upon the current path.

A colon (:) is not required at the start of the header of a simple or compound command. However, to avoid confusion with abbreviated forms and operating mistakes, Hioki recommends to always place a colon (:) at the start of a header.

## Output queue and input buffer

---

### Output queue

Response messages are stored in the output queue until read by the controller. The output queue is also cleared in the following circumstances.

- When the power is turned on
- Query error

At a minimum, the device's output queue can buffer a 64-byte response message.

When using the RS-232C interface, data in excess of that length may result in the output buffer being cleared due to a query error.

When using the LAN or USB interface, query operation will enter a wait state once the buffer is full and continue in that state until the data is received.

### Input buffer

The input buffer can accommodate a minimum of 256 characters.

When using the RS-232C interface, data may be lost in the event of a buffer overrun.

When using the LAN or USB interface, operation will enter a wait state once the buffer becomes full and continue in that state until the buffer is empty.

# Status Byte Register

This device implements the status model defined by IEEE 488.2 with regard to the serial poll function using the service request line. The term “event” refers to any occurrence that generates a service request.

## Overview of service request occurrence

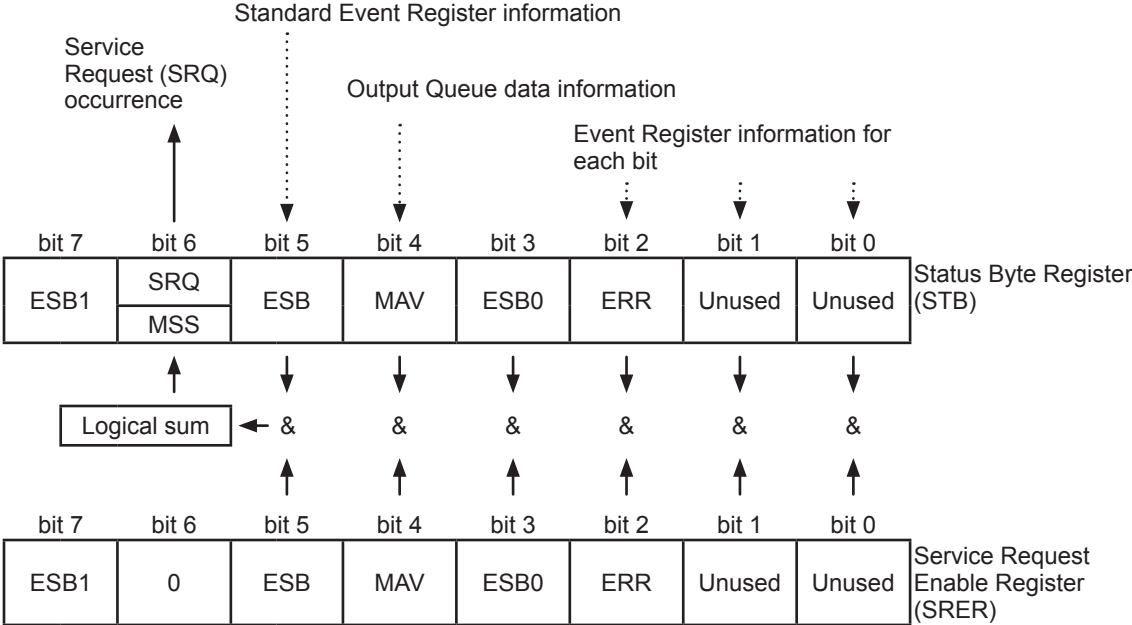

The Status Byte Register contains information about the event registers and the output queue. Required items are selected from this information by masking with the Service Request Enable Register. When any bit selected by the mask is set, bit 6 (MSS; the Master Summary Status) of the Status Byte Register is also set, which generates an SRQ (Service Request) message and dispatches a service request.



## Status Byte Register (STB)

During serial polling, the contents of the 8-bit Status Byte Register are sent from the instrument to the controller.

When any Status Byte Register bit enabled by the Service Request Enable Register has switched from “0” to “1”, the MSS bit becomes “1”. Consequently, the SRQ bit is set to “1”, and a service request is dispatched.

The SRQ bit is always synchronous with service requests, and is read and simultaneously cleared during serial polling. Although the MSS bit is only read by an **\*STB?** query, it is not cleared until a clear event is initiated by the **\*CLS** command.

|       |            |  |
|-------|------------|--|
| Bit 7 | ESB1       | Event Summary (logical sum) bit 1<br>This is the logical sum of the Standard Operation Register.                             |
| Bit 6 | SRQ<br>MSS | Set to “1” when a service request is dispatched.<br>This is the logical sum of the other bits of the Status Byte Register.   |
| Bit 5 | ESB        | Standard Event Summary (logical sum) bit<br>This is logical sum of the Standard Event Status Register.                       |
| Bit 4 | MAV        | Message available<br>Indicates that a message is present in the output queue.  |
| Bit 3 | ESB0       | Event Summary (logical sum) bit 0<br>This is the logical sum of the Status Query Register.                                   |
| Bit 2 | ERR        | Error bit<br>Set to “1” when error information is present.<br>Reset using <b>:SYSTem.ERRor?</b> to output error information. |
| Bit 1 | –          | Unused   |
| Bit 0 | –          | Unused   |

## Service Request Enable Register (SRER)

Setting a bit of this register to “1” enables the corresponding bit of the Status Byte Register to be used.

# Event Registers

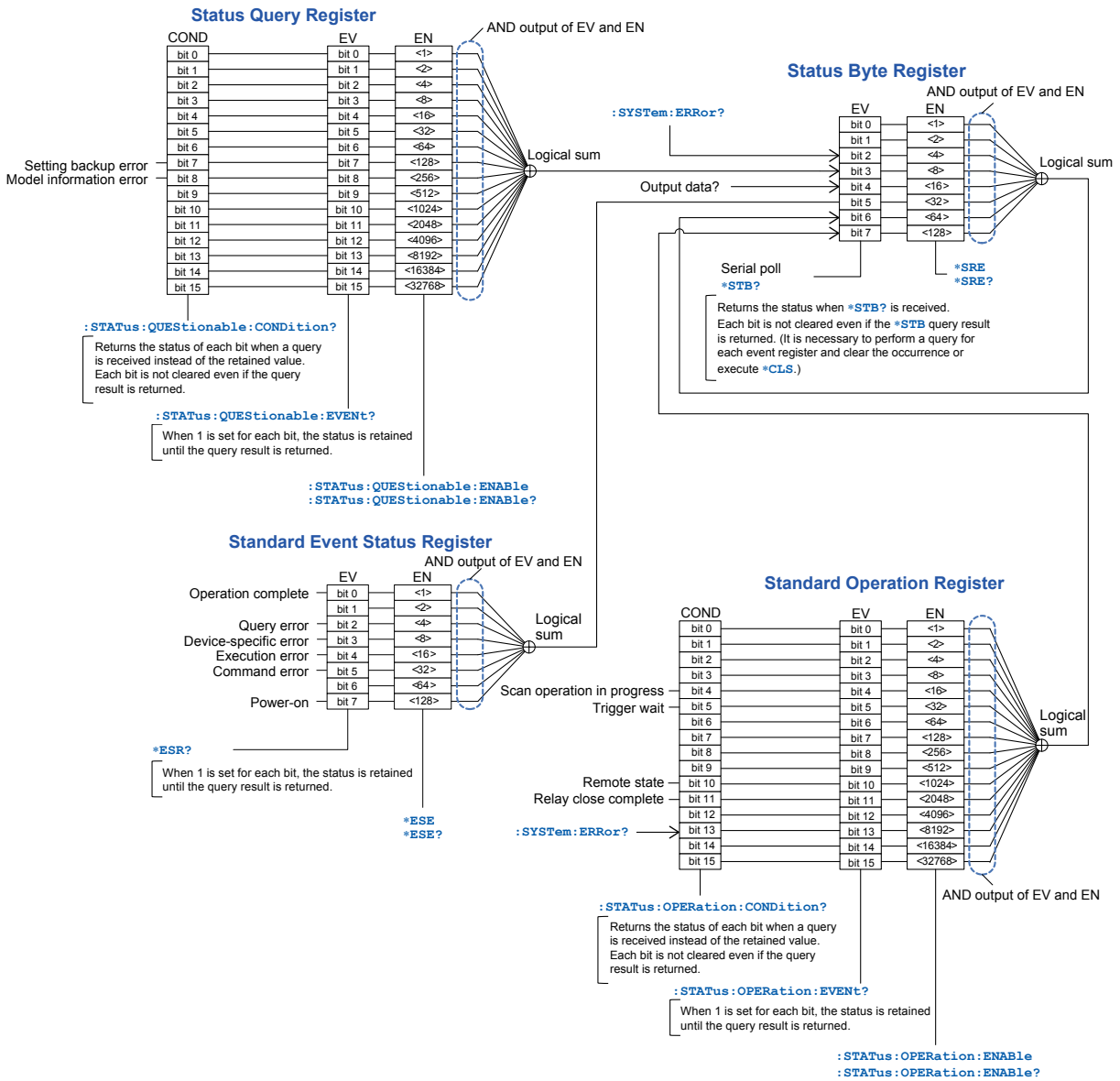

## Standard Event Status Register (SESR)

The Standard Event Status Register is an 8-bit register. If any bit in the Standard Event Status Register is set to "1" (within the enabled bits set by the Standard Event Status Enable Register), bit 5 (ESB) of the Status Byte Register is set to "1".

See: "Standard Event Status Register (SESR) and Standard Event Status Enable Register (SESER)" (p.81)

The Standard Event Register is cleared in the following situations:

- When a **\*CLS** command is executed
- When an event register query (**\*ESR?**) is executed
- When the power is turned on again

|       |                 |   |
|-------|-----------------|---|
| Bit 7 | PON             | Power-On Flag<br>Set to "1" when the power is turned on, or upon recovery from an outage.   |
| Bit 6 | URQ<br>(Unused) | Not used by this device<br>User Request   |
| Bit 5 | CME             | Command error (The command to the message terminator is ignored.)<br>Set to "1" when a received command contains a syntactic or semantic error. <ul style="list-style-type: none"> <li>• Program header error</li> <li>• Incorrect number of data parameters</li> <li>• Invalid parameter format</li> <li>• Received a command not supported by the device</li> </ul> |
| Bit 4 | EXE             | Execution error<br>Set to "1" when a received command cannot be executed for some reason. <ul style="list-style-type: none"> <li>• The specified data value is outside of the set rang</li> <li>• The specified setting data cannot be se</li> <li>• Execution is prevented by some other operation being performed</li> </ul>  |
| Bit 3 | DDE             | Device-dependent error<br>Set to "1" in the event of a backup error, self-test error, communications parameter error, communications timeout, or other issue.   |
| Bit 2 | QYE             | Query error (The output queue is cleared.)<br>Set to "1" when a query error is detected by the output queue control. <ul style="list-style-type: none"> <li>• When the data overflows the output queu</li> <li>• When data in the output queue has been lost</li> </ul>   |
| Bit 1 | RQC<br>(Unused) | Not used by this device.<br>Request control   |
| Bit 0 | OPC             | Operation complete <ul style="list-style-type: none"> <li>• Execution of an <b>*OPC</b> command.</li> <li>• Completion of operations of all messages up to the <b>*OPC</b> command.</li> </ul>  |

### Standard Event Status Enable Register (SESER)

Setting any bit of the Standard Event Status Enable Register to “1” enables access to the corresponding bit of the Standard Event Status Register.

### Standard Event Status Register (SESR) and Standard Event Status Enable Register (SESER)

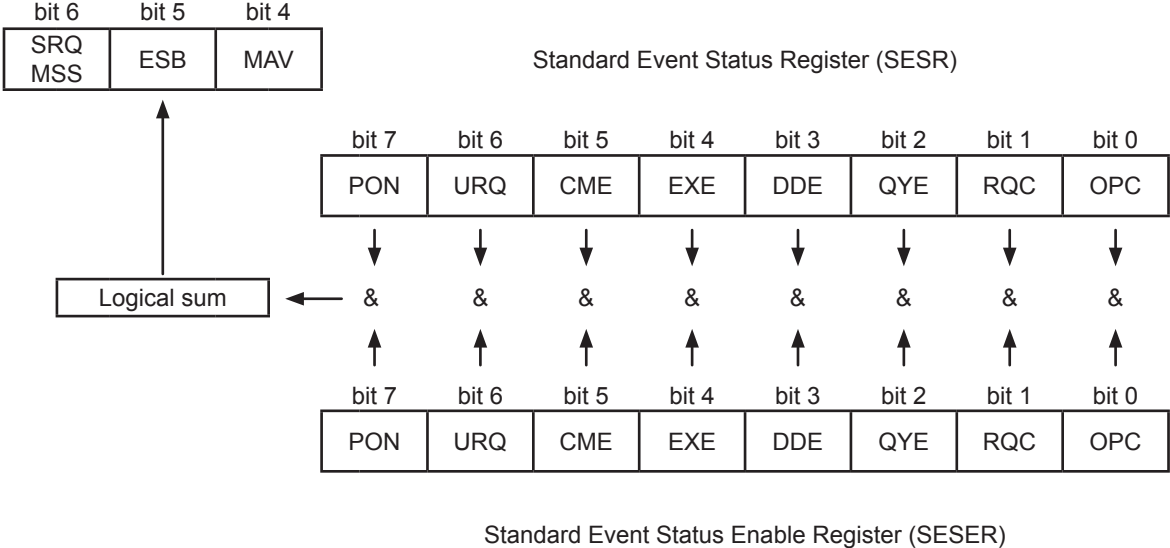

## Device-specific Event Status Register

This device provides two Event Status Registers for controlling events.

The Event Status Register is an 16-bit register.

When any bit in one of these Event Status Registers enabled by its corresponding Enable Register is set to "1", the following happens:

- For Standard Operation Register: Bit 7 (ESB1) of the Status Byte Register is set to "1".
- For Status Query Register: Bit 3 (ESB0) of the Status Byte Register is set to "1".

Event Status Registers 0 and 1 are cleared in the following situations:

- When a **\*CLS** command is executed
- When an Event Status Register query is executed  
(**:STATUS:OPERation:EVENT?**, **:STATUS:QUESTionable:EVENT?**)
- When the power is turned on again

| Standard Operation Register |          |  |
|-----------------------------|----------|--|
| Bit 15                      | –        | Unused   |
| Bit 14                      | –        | Unused   |
| Bit 13                      | ERR      | Set to “1” when an error occurs (cleared when details are acquired from : <b>SYSTem</b> . <b>ERRor?</b> ). |
| Bit 12                      | –        | Unused   |
| Bit 11                      | CLOSE    | Set to “1” when channel closing is completed.  |
| Bit 10                      | REMOTE   | Set to “1” when the device is in the remote state.   |
| Bit 9                       | –        | Unused   |
| Bit 8                       | –        | Unused   |
| Bit 7                       | –        | Unused   |
| Bit 6                       | –        | Unused   |
| Bit 5                       | WAIT_TRG | Set to “1” when the device is in the trigger waiting state.  |
| Bit 4                       | SCAN     | Set to “1” when scan is operating.   |
| Bit 3                       | –        | Unused   |
| Bit 2                       | –        | Unused   |
| Bit 1                       | –        | Unused   |
| Bit 0                       | –        | Unused   |

**Event Register of the Standard Operation Register Group (:**STATus**:**OPERation**:**EVENT?**) and Enable Register of the Standard Operation Register Group (:**STATus**:**OPERation**:**ENABLE**)**

Status Byte Register (STB)

|       |         |       |
|-------|---------|-------|
| bit 7 | bit 6   | bit 5 |
| ESB1  | SRQ/MSS | MAV   |

Event Register of the Standard Operation Register Group  
(:**STATus**:**OPERation**:**EVENT?**)

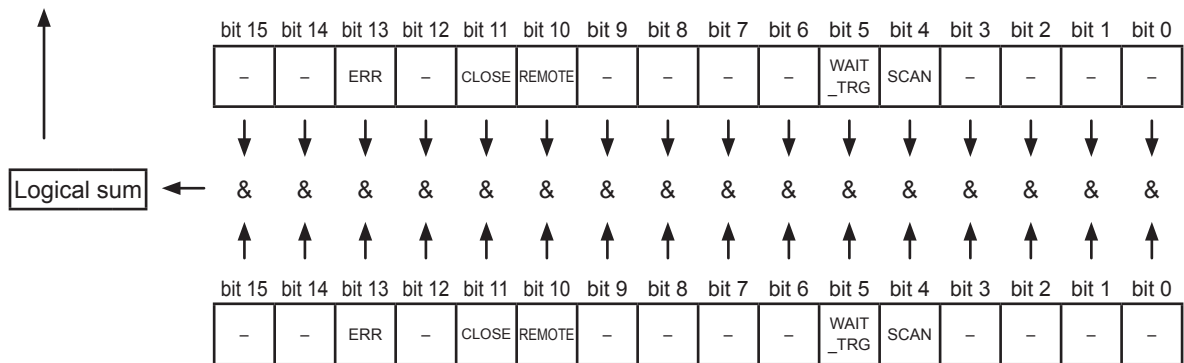

Enable Register of the Standard Operation Register Group  
(:**STATus**:**OPERation**:**ENABLE**)

| Status Query Register |            |                         |
|-----------------------|------------|-------------------------|
| Bit 15                | –          | Unused                  |
| Bit 14                | –          | Unused                  |
| Bit 13                | –          | Unused                  |
| Bit 12                | –          | Unused                  |
| Bit 11                | –          | Unused                  |
| Bit 10                | –          | Unused                  |
| Bit 9                 | –          | Unused                  |
| Bit 8                 | INFO_ERR   | Model information error |
| Bit 7                 | BACKUP_ERR | Setting backup error    |
| Bit 6                 | –          | Unused                  |
| Bit 5                 | –          | Unused                  |
| Bit 4                 | –          | Unused                  |
| Bit 3                 | –          | Unused                  |
| Bit 2                 | –          | Unused                  |
| Bit 1                 | –          | Unused                  |
| Bit 0                 | –          | Unused                  |

**Event Register of the Status Query Register Group (:STATUS:QUESTIONABLE:EVENT?) and Enable Register of the Status Query Register Group (:STATUS:QUESTIONABLE:ENABLE)**

Status Byte Register (STB)

|       |       |       |
|-------|-------|-------|
| bit 4 | bit 3 | bit 2 |
| MAV   | ESB0  | ERR   |

Event Register of the Status Query Register Group  
(:STATUS:QUESTIONABLE:EVENT?)

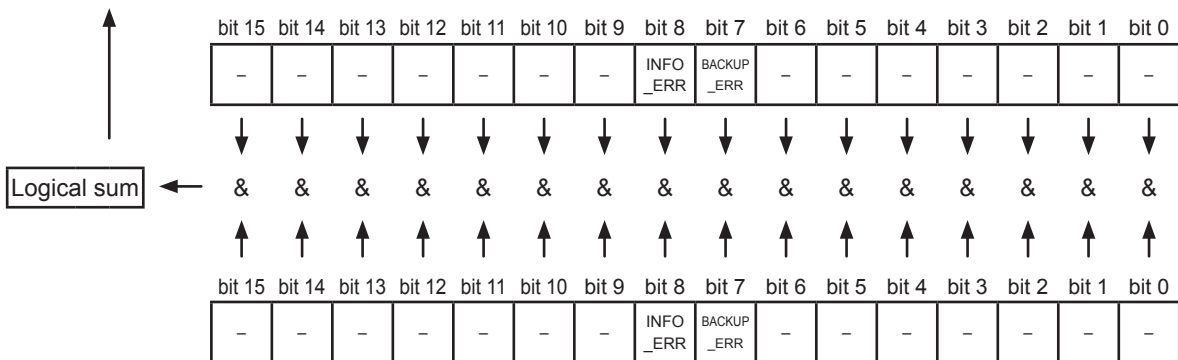

Enable Register of the Status Query Register Group  
(:STATUS:QUESTIONABLE:ENABLE)

## Register query and setting

| Register  | Query                                  | Setting                            |
|---|--|------------------------------------|
| Status Byte Register  | <b>*STB?</b>                           | –                                  |
| Service Request Enable Register   | <b>*SRE?</b>                           | <b>*SRE</b>                        |
| Standard Event Status Register  | <b>*ESR?</b>                           | –                                  |
| Standard Event Status Enable Register                                     | <b>*ESE?</b>                           | <b>*ESE</b>                        |
| Condition Register of the Standard Operation Register Group (status data) | <b>:STATUS:OPERATION:CONDITION?</b>    | –                                  |
| Event Register of the Standard Operation Register Group (event data)      | <b>:STATUS:OPERATION:EVENT?</b>        | –                                  |
| Enable Register of the Standard Operation Register Group                  | <b>:STATUS:OPERATION:ENABLE?</b>       | <b>:STATUS:OPERATION:ENABLE</b>    |
| Condition Register of the Status Query Register Group (status data)       | <b>:STATUS:QUESTIONABLE:CONDITION?</b> | –                                  |
| Event Register of the Status Query Register Group (event data)            | <b>:STATUS:QUESTIONABLE:EVENT?</b>     | –                                  |
| Enable Register of the Status Query Register Group                        | <b>:STATUS:QUESTIONABLE:ENABLE?</b>    | <b>:STATUS:QUESTIONABLE:ENABLE</b> |



## Initialization items

✓: Yes, –: No

| Register                                | When the power is turned on | *RST Command | *CLS Command |
|---|-----------------------------|--------------|--------------|
| Device-specific functions (range, etc.) | –                           | ✓            | –            |
| Output queue                            | ✓                           | –            | –            |
| Input buffer                            | ✓                           | –            | –            |
| Status Byte Register                    | ✓                           | –            | ✓ *2         |
| Event Register                          | ✓ *3                        | –            | ✓            |
| Enable Register                         | ✓                           | –            | –            |
| Current path                            | ✓                           | –            | –            |

\*1: Only the MAV bit (bit 4) is cleared.

\*2: All bits except the MAV bit are cleared.

\*3: Except the PON bit (bit 7).

## Remote state

The device enters the remote state during communications and the **REMOTE** lamp lights up. The remote state cannot be cancelled.

## 8.8 Message List

| Message<br>[: Omissible]        | Data<br>[: Omissible,<br>( ): Response data]                       | Description  | Reference |
|---------------------------------|--|--|-----------|
| *IDN?                           | (<Manufacturer name>,<Model name>,<Serial No.>,<Software version>) | Queries the device ID (ID code).   | p.91      |
| *RST                            |  | Initializes the device.  | p.91      |
| *TST?                           | (<PASS/FAIL>)  | Initiates a self-test and queries the result.                                | p.91      |
| *TRG                            |  | Trigger  | p.91      |
| *OPC                            |  | Wait for the present operation to complete and then set OPC of SESR.         | p.92      |
| *OPC?                           | (1)  | Wait for the present operation to complete and then respond with ASCII "1" . | p.92      |
| *WAI                            |  | Wait for the present operation to complete.                                  | p.92      |
| *CLS                            |  | Clears the Event Register and the Status Byte Register.                      | p.92      |
| *ESE                            | 0 to 255   | Sets the Standard Event Status Enable Register (SESER).                      | p.92      |
| *ESE?                           | (0 to 255)   | Queries the Standard Event Status Enable Register (SESER).                   | p.92      |
| *ESR?                           | (0 to 255)   | Queries the Standard Event Status Register (SESR).                           | p.93      |
| *SRE                            | 0 to 255   | Sets the Service Request Enable Register (SRER).                             | p.93      |
| *SRE?                           | (0 to 255)   | Queries the Service Request Enable Register (SRER).                          | p.93      |
| *STB?                           | (0 to 255)   | Queries the Status Byte Register.  | p.93      |
| :STATUS:OPERation:CONDition?    | (0 to 65535)   | Queries the Condition Register of the Standard Operation Register Group.     | p.94      |
| :STATUS:OPERation[:EVENT]?      | (0 to 65535)   | Queries the Event Register of the Standard Operation Register Group.         | p.94      |
| :STATUS:OPERation:ENABLE        | 0 to 65535   | Sets the Enable Register of the Standard Operation Register Group.           | p.94      |
| :STATUS:OPERation:ENABLE?       | (0 to 65535)   | Queries the Enable Register of the Standard Operation Register Group.        | p.94      |
| :STATUS:QUEStionable:CONDition? | (0 to 65535)   | Queries the Condition Register of the Status Query Register Group.           | p.95      |
| :STATUS:QUEStionable[:EVENT]?   | (0 to 65535)   | Queries the Event Register of the Status Query Register Group                | p.95      |
| :STATUS:QUEStionable:ENABLE     | 0 to 65535   | Sets the Enable Register of the Status Query Register Group.                 | p.95      |
| :STATUS:QUEStionable:ENABLE?    | (0 to 65535)   | Queries the Enable Register of the Status Query Register Group.              | p.95      |
| :STATUS:PRESet                  |  | Initialize the device.<br>(Same setting as *RST)                             | p.106     |

| Message<br>[ ]: Omissible | Data<br>[ ]: Omissible,<br>( ): Response data                        | Description   | Reference |
|---------------------------|--|---|-----------|
| :ABORt                    |  | Reset of the scan operation.                        | p. 100    |
| :SYSTem:PRESet            |  | Initialize the device.<br>(Same setting as *RST)    | p. 106    |
| :SYSTem:ERRor?            | (<Error No.>,<Error message>)  | Queries and clears the error information.           | p. 100    |
| :SYSTem:BACKup            |  | Backup of the setting.                              | p. 105    |
| :SYSTem:CTYPe?            | <Slot No.><br>(<Manufacturer name>,<Model name>,<Serial No.>)        | Queries the slot module information.                | p. 105    |
| :SYSTem:MODule:WIRE:MODE  | <Slot No.>,<WIRE2/<br>WIRE4/TP4>                                     | Sets the connection method.                         | p. 96     |
| :SYSTem:MODule:WIRE:MODE? | <Slot No.><br>(<WIRE2/WIRE4/TP4>)                                    | Queries the connection method.                      |           |
| :SYSTem:MODule:SHIeld     | <Slot No.>,<OFF/GND/<br>TERMinal1/TERMinal2/<br>TERMinal3/T1T3>      | Switches the shield.                                | p. 97     |
| :SYSTem:MODule:SHIeld?    | <Slot No.><br>(<OFF/GND/TERMinal1/<br>TERMinal2/TERMinal3/<br>T1T3>) | Queries the shield switching.                       |           |
| :SYSTem:MODule:DElay      | <Slot No.>,<Time/MIN/<br>MAX/DEF>                                    | Sets the channel delay time.                        | p. 98     |
| :SYSTem:MODule:DElay?     | <Slot No.><br>(<Time>)   | Queries the channel delay time.                     |           |
| :SYSTem:MODule:COUnT?     | <Slot No.>,<Relay No.><br>(<Relay opening/closing<br>frequency>)     | Queries the relay opening/closing frequency.        | p. 106    |
| [ :ROUte ] :CLOSe         | <CH>   | Selects and queries the channel.                    | p. 98     |
| [ :ROUte ] :CLOSe?        | (<CH>)   |   |           |
| [ :ROUte ] :OPEN          |  | Opens all relays.                                   | p. 98     |
| [ :ROUte ] :SCAN          | <Scan list>  | Scan list registration                              | p. 99     |
| [ :ROUte ] :SCAN?         | (<Scan list>)  | Queries the scan list.                              |           |
| [ :ROUte ] :SCAN:ADD      | <Scan list>  | Adds to the scan list.                              | p. 99     |
| [ :ROUte ] :SCAN:REMOve   |  | Deletes the scan lists.                             | p. 99     |
| [ :ROUte ] :SCAN:SIze?    | (<Addable count>)  | Queries the number of scan lists that can be added. | p. 100    |
| :TRIGger:SOURce           | <STEP>   | Sets the trigger source for scan operation.         | p. 100    |
| :TRIGger:SOURce?          | (<STEP>)   | Queries the trigger source for scan operation.      |           |

| Message<br>[: Omissible]                  | Data<br>[: Omissible,<br>( ): Response data]               | Description   | Reference |
|---|--|---|-----------|
| :IO:FILTER:STATE                          | <1/0/ON/OFF>   | Sets the EXT. I/O input terminal filter function.   | p. 102    |
| :IO:FILTER:STATE?                         | <1/0>  | Queries the EXT. I/O input terminal filter function                                       |           |
| :IO:FILTER:TIME                           | <Filter time 0.05 to 0.50/<br>MIN/MAX/DEF>                 | Sets the EXT. I/O input terminal filter time.   | p. 102    |
| :IO:FILTER:TIME?                          | <Time>   | Queries the EXT. I/O input terminal filter time   |           |
| :IO:PULSE:TIME                            | <Pulse time 0.001 to<br>0.100/MIN/MAX/DEF>                 | Sets the CLOSE signal pulse width.  | p. 102    |
| :IO:PULSE:TIME?                           | <Time>   | Queries the CLOSE signal pulse width.   |           |
| :SYSTEM:COMMUNICATE:LAN:CONTROL           | <Port No. 1 to 65535>                                      | Sets the communication command port No.   | p. 103    |
| :SYSTEM:COMMUNICATE:LAN:CONTROL?          | <Port No.>   | Queries the communication command port No.  |           |
| :SYSTEM:COMMUNICATE:LAN:GATEWAY           | <Gateway IP address 0<br>- 255,0 - 255,0 - 255,0 -<br>255> | Sets the default gateway.   | p. 103    |
| :SYSTEM:COMMUNICATE:LAN:GATEWAY?          | <Gateway address>  | Queries the default gateway.  |           |
| :SYSTEM:COMMUNICATE:LAN:IPADDRESS         | <IP address 0 - 255,0 -<br>255,0 - 255,0 - 255>            | Sets the IP address.  | p. 104    |
| :SYSTEM:COMMUNICATE:LAN:IPADDRESS?        | <IP address>   | Queries the IP address.   |           |
| :SYSTEM:COMMUNICATE:LAN:SMASK             | <Subnet mask 0 - 255,0 -<br>255,0 - 255,0 - 255>           | Sets the subnet mask.   | p. 104    |
| :SYSTEM:COMMUNICATE:LAN:SMASK?            | <Subnet mask>  | Queries the subnet mask.  |           |
| :SYSTEM:COMMUNICATE:LAN:MAC?              | <MAC address>  | Queries the MAC address.  | p. 105    |
| :SYSTEM:COMMUNICATE:LAN:UPDATE            |  | Apply the LAN settings.   | p. 105    |
| :SYSTEM:COMMUNICATE:RS232C:SPEED          | <9600/19200/38400>   | Sets the RS-232C communication speed.   | p. 103    |
| :SYSTEM:COMMUNICATE:RS232C:SPEED?         | <9600/19200/38400>   | Queries the RS-232C communication speed.  |           |
| :SYSTEM:COMMUNICATE:FORWARD:RS232C:SPEED  | <9600/19200/38400>   | Sets the RS-232C communication speed of the communication command forwarding function.    | p. 101    |
| :SYSTEM:COMMUNICATE:FORWARD:RS232C:SPEED? | <9600/19200/38400>   | Queries the RS-232C communication speed of the communication command forwarding function. |           |
| :SYSTEM:COMMUNICATE:FORWARD:TIMEOUT       | <Timeout time 1 to 100>                                    | Sets the query forward timeout.   | p. 101    |
| :SYSTEM:COMMUNICATE:FORWARD:TIMEOUT?      | <Timeout time 1 to 100>                                    | Queries the query forward timeout.  |           |
| :A  | <Command character<br>string to be forwarded>              | Transfers the command or query to forward destination A.                                  | p. 101    |
| :TEST:RELAYSHORT                          | <Slot No.>,<CH/BUS/<br>OPEN>                               | Relay contact welding test  | p. 106    |

# 8.9 Message Reference

|          |  |   |                     |       |       |       |       |  |       |       |       |       |       |       |       |       |     |     |     |     |     |     |     |     |
|----------|--|---|---------------------|-------|-------|-------|-------|--|-------|-------|-------|-------|-------|-------|-------|-------|-----|-----|-----|-----|-----|-----|-----|-----|
| <b>2</b> | <b>Set and query Standard Event Status Enable Register (SESER)</b> |   |                     |       |       |       |       |  |       |       |       |       |       |       |       |       |     |     |     |     |     |     |     |     |
| <b>3</b> | <b>Syntax</b>  | Command   | *ESE <0-255 (NR1) > |       |       |       |       |  |       |       |       |       |       |       |       |       |     |     |     |     |     |     |     |     |
|          |  | Query   | *ESE?               |       |       |       |       |  |       |       |       |       |       |       |       |       |     |     |     |     |     |     |     |     |
|          |  | Response  | <0 to 255 (NR1)>    |       |       |       |       |  |       |       |       |       |       |       |       |       |     |     |     |     |     |     |     |     |
| <b>4</b> | <b>Description</b>   | <p>The SESER mask is set to a numerical value from 0 to 255. The initial value when the power is turned ON is 0. When an event applicable to the specified bit occurs, bit 5, the Event Status Bit (ESB) of the Status Byte Register (STB) is set.</p> <table border="1" style="margin-left: auto; margin-right: auto;"> <tr> <td style="text-align: center;">bit 7</td> <td style="text-align: center;">bit 6</td> <td style="text-align: center;">bit 5</td> <td style="text-align: center;">bit 4</td> <td style="text-align: center;">bit 3</td> <td style="text-align: center;">bit 2</td> <td style="text-align: center;">bit 1</td> <td style="text-align: center;">bit 0</td> </tr> <tr> <td style="text-align: center;">PON</td> <td style="text-align: center;">URQ</td> <td style="text-align: center;">CME</td> <td style="text-align: center;">EXE</td> <td style="text-align: center;">DDE</td> <td style="text-align: center;">QYE</td> <td style="text-align: center;">RQC</td> <td style="text-align: center;">OPC</td> </tr> </table> |                     |       |       |       |       |  | bit 7 | bit 6 | bit 5 | bit 4 | bit 3 | bit 2 | bit 1 | bit 0 | PON | URQ | CME | EXE | DDE | QYE | RQC | OPC |
| bit 7    | bit 6  | bit 5   | bit 4               | bit 3 | bit 2 | bit 1 | bit 0 |  |       |       |       |       |       |       |       |       |     |     |     |     |     |     |     |     |
| PON      | URQ  | CME   | EXE                 | DDE   | QYE   | RQC   | OPC   |  |       |       |       |       |       |       |       |       |     |     |     |     |     |     |     |     |
| <b>5</b> | <b>Example</b>   | <p>*ESE 36<br/>Sets bit 5 and 2 of the SESER.</p>   |                     |       |       |       |       |  |       |       |       |       |       |       |       |       |     |     |     |     |     |     |     |     |

| No.      | Description  |
|----------|--|
| <b>1</b> | <p>&lt; &gt;: Indicates the contents (character or numeric parameters) of the data portion of a message. Character parameters are returned as all capital letters.</p> <p>Numeric Parameters:</p> <ul style="list-style-type: none"> <li>• NRf: Number format may be any of NR1, NR2 and NR3.</li> <li>• NR1: Integer data (e.g.: +12, -23, 34)</li> <li>• NR2: Fixed-point data (e.g.: +1.23, -23.45, 3.456)</li> <li>• NR3: Floating-point exponential representation data (e.g.: +1.0E-2, -2.3E+4)</li> </ul> |
| <b>2</b> | Shows the command description.   |
| <b>3</b> | Shows the message syntax.<br>Describes the command data portion or response message.   |
| <b>4</b> | Describes the message.   |
| <b>5</b> | Shows an example of an actual command application. The description of a command application usually refers to when the header is on (except header commands).  |

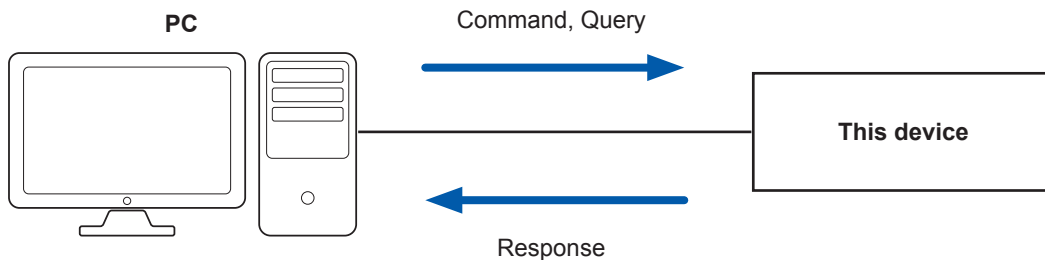

## Standard commands

### (1) System data command

| Query device ID (ID code) |  |  |
|---------------------------|--|--|
| Syntax                    | Query  | <b>*IDN?</b>   |
|                           | Response   | <Manufacturer name>,<Model name>,<Serial No.>,<Software version> |
| Example                   | <b>*IDN?</b><br><b>HIOKI,SW1001,123456789,V1.00</b><br>For the SW1002, the <Model name> is "SW1002". |  |

### (2) Internal operation commands

| Initializes the device. |   |             |
|-------------------------|---|-------------|
| Syntax                  | Command   | <b>*RST</b> |
| Description             | Resets the device to its initial state.<br>See: "6.1 Initialization Settings" (p.47)  |             |
| Note                    | <ul style="list-style-type: none"> <li>The communication conditions are not initialized.</li> <li>All closed channels are opened.</li> <li>Initialized settings are not preserved when the power is turned off. To save initialized settings, execute the <b>SYSTem:BACKup</b> command.<br/>See: "Backing up settings" (p.105)</li> </ul> |             |

| Initiates a self-test and queries the result. |   |              |
|---|---|--------------|
| Syntax  | Query   | <b>*TST?</b> |
|   | Response  | <PASS/FAIL>  |
| Description                                   | Performs the device self-test and returns the result.<br>Returns PASS when no error occurs and FAIL when an error occurs. |              |
| Example                                       | <b>*TST?</b><br><b>PASS</b><br>A self-test was executed and no error occurred.  |              |
| Note  | An execution error occurs during scan operation.  |              |

| Trigger     |  |             |
|-------------|--|-------------|
| Syntax      | Command  | <b>*TRG</b> |
| Description | Starts scan operation when the scan list is enabled. During scan operation, switches to the next channel as specified by the registered scan list. |             |
| Example     | <b>*TRG</b><br>During scan operation, switches to the next channel as specified by the registered scan list.                                       |             |

(3) Synchronized commands

| Set the OPC of the SESR register when finished with all pending operation |   |      |
|---|---|------|
| <b>Syntax</b>   | Command   | *OPC |
| <b>Description</b>  | Sets "OPC bit 0" of the Standard Event Status Register (SESR) when the present operation is completed.<br>The next command does not execute until the present operation is completed. |      |
| <b>Example</b>  | *OPC<br>*ESR?<br>1  |      |

| Wait for the present operation to complete and respond with 1 |   |       |
|---|---|-------|
|   | Query   | *OPC? |
|   | Response  | 1     |
| <b>Description</b>  | Waits for the present operation to complete and responds with 1.<br>The next command does not execute until the present operation is completed. |       |
| <b>Example</b>  | :ROUT:OPEN<br>*OPC?<br>1<br>Responds with 1 when all relays are opened and all commands are completed.  |       |

| Wait for the present operation to complete |  |      |
|--|--|------|
| <b>Syntax</b>                              | Command  | *WAI |
| <b>Description</b>                         | Waits for the present operation to complete.<br>The next command does not execute until the present operation is completed, however, the :ABORT and *TRG commands are accepted.<br>Unlike *OPC, the Standard Event Status Register (SESR) is not set. Everything else is the same. |      |

(4) Status and event control commands

| Clear the Event Registers and the Status Byte Register |   |      |
|--|---|------|
| <b>Syntax</b>  | Command   | *CLS |
| <b>Description</b>                                     | Clears the Event Status Registers. The Status Byte Register bits corresponding to the Event Status Registers are also cleared. Errors are also cleared. |      |

| Set and query Standard Event Status Enable Register (SESER) |  |                     |       |       |       |       |       |       |       |       |     |     |     |     |     |     |     |     |
|---|--|---------------------|-------|-------|-------|-------|-------|-------|-------|-------|-----|-----|-----|-----|-----|-----|-----|-----|
| <b>Syntax</b>   | Command  | *ESE <0-255 (NR1) > |       |       |       |       |       |       |       |       |     |     |     |     |     |     |     |     |
|   | Query  | *ESE?               |       |       |       |       |       |       |       |       |     |     |     |     |     |     |     |     |
|   | Response   | <0 to 255 (NR1)>    |       |       |       |       |       |       |       |       |     |     |     |     |     |     |     |     |
| <b>Description</b>  | The SESER mask is set to a numerical value from 0 to 255. The initial value when the power is turned on is 0. When an event applicable to the specified bit occurs, bit 5, the Event Status Bit (ESB) of the Status Byte Register (STB) is set.  |                     |       |       |       |       |       |       |       |       |     |     |     |     |     |     |     |     |
|   | <table border="1" style="width: 100%; text-align: center;"> <tr> <td>bit 7</td> <td>bit 6</td> <td>bit 5</td> <td>bit 4</td> <td>bit 3</td> <td>bit 2</td> <td>bit 1</td> <td>bit 0</td> </tr> <tr> <td>PON</td> <td>URQ</td> <td>CME</td> <td>EXE</td> <td>DDE</td> <td>QYE</td> <td>RQC</td> <td>OPC</td> </tr> </table> |                     | bit 7 | bit 6 | bit 5 | bit 4 | bit 3 | bit 2 | bit 1 | bit 0 | PON | URQ | CME | EXE | DDE | QYE | RQC | OPC |
| bit 7   | bit 6  | bit 5               | bit 4 | bit 3 | bit 2 | bit 1 | bit 0 |       |       |       |     |     |     |     |     |     |     |     |
| PON   | URQ  | CME                 | EXE   | DDE   | QYE   | RQC   | OPC   |       |       |       |     |     |     |     |     |     |     |     |
| <b>Example</b>  | *ESE 36<br>Sets bit 5 and 2 of the SESER.  |                     |       |       |       |       |       |       |       |       |     |     |     |     |     |     |     |     |

| Query Standard Event Status Register (SESR) |  |                  |       |       |       |       |       |       |       |       |     |   |     |     |     |     |   |
|---|--|------------------|-------|-------|-------|-------|-------|-------|-------|-------|-----|---|-----|-----|-----|-----|---|
| <b>Syntax</b>                               | Query  | *ESR?            |       |       |       |       |       |       |       |       |     |   |     |     |     |     |   |
|   | Response   | <0 to 255 (NR1)> |       |       |       |       |       |       |       |       |     |   |     |     |     |     |   |
| <b>Description</b>                          | Returns the SESR value. Unused bits (indicated in the following chart by “–”) return the value 0.  |                  |       |       |       |       |       |       |       |       |     |   |     |     |     |     |   |
|   | <table border="1" style="width: 100%; text-align: center;"> <tr> <td>bit 7</td> <td>bit 6</td> <td>bit 5</td> <td>bit 4</td> <td>bit 3</td> <td>bit 2</td> <td>bit 1</td> <td>bit 0</td> </tr> <tr> <td>PON</td> <td>–</td> <td>CME</td> <td>EXE</td> <td>DDE</td> <td>QYE</td> <td>–</td> <td>OPC</td> </tr> </table> |                  | bit 7 | bit 6 | bit 5 | bit 4 | bit 3 | bit 2 | bit 1 | bit 0 | PON | – | CME | EXE | DDE | QYE | – |
| bit 7                                       | bit 6  | bit 5            | bit 4 | bit 3 | bit 2 | bit 1 | bit 0 |       |       |       |     |   |     |     |     |     |   |
| PON   | –  | CME              | EXE   | DDE   | QYE   | –     | OPC   |       |       |       |     |   |     |     |     |     |   |
| <b>Example</b>                              | *OPC<br>*ESR?<br>1<br>*OPC confirms that the OPC bit of the SESR has been set  |                  |       |       |       |       |       |       |       |       |     |   |     |     |     |     |   |

| Set and query Service Request Enable Register (SRER) |  |                  |       |       |       |       |       |   |   |   |       |       |       |       |       |       |       |       |      |   |     |     |      |     |   |
|--|--|------------------|-------|-------|-------|-------|-------|---|---|---|-------|-------|-------|-------|-------|-------|-------|-------|------|---|-----|-----|------|-----|---|
| <b>Syntax</b>  | Command  | *SRE             |       |       |       |       |       |   |   |   |       |       |       |       |       |       |       |       |      |   |     |     |      |     |   |
|  | Query  | *SRE?            |       |       |       |       |       |   |   |   |       |       |       |       |       |       |       |       |      |   |     |     |      |     |   |
|  | Response   | <0 to 255 (NR1)> |       |       |       |       |       |   |   |   |       |       |       |       |       |       |       |       |      |   |     |     |      |     |   |
| <b>Description</b>                                   | The SRER mask pattern is set to a numerical value from 0 to 255. The initial value when the power is turned on is 0. Unused bits are always returned as 0 for a query.   |                  |       |       |       |       |       |   |   |   |       |       |       |       |       |       |       |       |      |   |     |     |      |     |   |
|  | <table border="1" style="width: 100%; text-align: center;"> <tr> <td>128</td> <td>64</td> <td>32</td> <td>16</td> <td>8</td> <td>4</td> <td>2</td> <td>1</td> </tr> <tr> <td>bit 7</td> <td>bit 6</td> <td>bit 5</td> <td>bit 4</td> <td>bit 3</td> <td>bit 2</td> <td>bit 1</td> <td>bit 0</td> </tr> <tr> <td>ESB1</td> <td>0</td> <td>ESB</td> <td>MAV</td> <td>ESB0</td> <td>ERR</td> <td>–</td> <td>–</td> </tr> </table> |                  | 128   | 64    | 32    | 16    | 8     | 4 | 2 | 1 | bit 7 | bit 6 | bit 5 | bit 4 | bit 3 | bit 2 | bit 1 | bit 0 | ESB1 | 0 | ESB | MAV | ESB0 | ERR | – |
| 128  | 64   | 32               | 16    | 8     | 4     | 2     | 1     |   |   |   |       |       |       |       |       |       |       |       |      |   |     |     |      |     |   |
| bit 7  | bit 6  | bit 5            | bit 4 | bit 3 | bit 2 | bit 1 | bit 0 |   |   |   |       |       |       |       |       |       |       |       |      |   |     |     |      |     |   |
| ESB1   | 0  | ESB              | MAV   | ESB0  | ERR   | –     | –     |   |   |   |       |       |       |       |       |       |       |       |      |   |     |     |      |     |   |
| <b>Example</b>                                       | *SRE 4<br>Set so that the MSS bit of the STB is set when a system error occurs.<br>*SRE?<br>12<br>SRER bits 3 and 2 have been set to 1.  |                  |       |       |       |       |       |   |   |   |       |       |       |       |       |       |       |       |      |   |     |     |      |     |   |

| Query Status Byte Register |  |                  |       |       |       |       |       |       |       |       |      |     |     |     |      |     |   |
|----------------------------|--|------------------|-------|-------|-------|-------|-------|-------|-------|-------|------|-----|-----|-----|------|-----|---|
| <b>Syntax</b>              | Query  | *STB?            |       |       |       |       |       |       |       |       |      |     |     |     |      |     |   |
|                            | Response   | <0 to 255 (NR1)> |       |       |       |       |       |       |       |       |      |     |     |     |      |     |   |
| <b>Description</b>         | Returns the STB value. Unused bits (indicated in the following chart by “–”) return the value 0.   |                  |       |       |       |       |       |       |       |       |      |     |     |     |      |     |   |
|                            | <table border="1" style="width: 100%; text-align: center;"> <tr> <td>bit 7</td> <td>bit 6</td> <td>bit 5</td> <td>bit 4</td> <td>bit 3</td> <td>bit 2</td> <td>bit 1</td> <td>bit 0</td> </tr> <tr> <td>ESB1</td> <td>MSS</td> <td>ESB</td> <td>MAV</td> <td>ESB0</td> <td>ERR</td> <td>–</td> <td>–</td> </tr> </table> |                  | bit 7 | bit 6 | bit 5 | bit 4 | bit 3 | bit 2 | bit 1 | bit 0 | ESB1 | MSS | ESB | MAV | ESB0 | ERR | – |
| bit 7                      | bit 6  | bit 5            | bit 4 | bit 3 | bit 2 | bit 1 | bit 0 |       |       |       |      |     |     |     |      |     |   |
| ESB1                       | MSS  | ESB              | MAV   | ESB0  | ERR   | –     | –     |       |       |       |      |     |     |     |      |     |   |
| <b>Example</b>             | *STB?<br>4<br>STB bit 2 has been set to 1.   |                  |       |       |       |       |       |       |       |       |      |     |     |     |      |     |   |



## Device-specific command

### (1) Event Status Register

| Query Condition Register of Standard Operation Register Group |  |                                      |           |        |        |        |       |       |
|---|--|--------------------------------------|-----------|--------|--------|--------|-------|-------|
| <b>Syntax</b>   | Query  | : <b>STATus:OPERation:CONDition?</b> |           |        |        |        |       |       |
|   | Response   | <0 to 65535 (NR1)>                   |           |        |        |        |       |       |
| <b>Description</b>  | Returns the present standard operation register value. Unused bits (indicated in the following chart by “-”) return the value 0.   |                                      |           |        |        |        |       |       |
|   | bit 15   | bit 14                               | bit 13    | bit 12 | bit 11 | bit 10 | bit 9 | bit 8 |
|   | -  | -                                    | ERR       | -      | CLOSE  | REMOTE | -     | -     |
|   | bit 7  | bit 6                                | bit 5     | bit 4  | bit 3  | bit 2  | bit 1 | bit 0 |
|   | -  | -                                    | WAIT_ TRG | SCAN   | -      | -      | -     | -     |
| <b>Example</b>  | : <b>STAT:OPER:COND?</b><br>1024<br>The device is in the remote state.   |                                      |           |        |        |        |       |       |
| <b>Note</b>   | <ul style="list-style-type: none"> <li>The present status is returned when this command is received.</li> <li>Unlike :<b>STATus:OPERation:EVENT?</b>, :<b>STATus:OPERation?</b>, bit information is not retained.</li> </ul> |                                      |           |        |        |        |       |       |

| Query Event Register of Standard Operation Register Group |   |                                    |           |        |        |        |       |       |
|---|---|------------------------------------|-----------|--------|--------|--------|-------|-------|
| <b>Syntax</b>   | Query   | : <b>STATus:OPERation[:EVENT]?</b> |           |        |        |        |       |       |
|   | Response  | <0 to 65535 (NR1)>                 |           |        |        |        |       |       |
| <b>Description</b>  | Returns the retained standard operation register value. Unused bits (indicated in the following chart by “-”) return the value 0.   |                                    |           |        |        |        |       |       |
|   | bit 15  | bit 14                             | bit 13    | bit 12 | bit 11 | bit 10 | bit 9 | bit 8 |
|   | -   | -                                  | ERR       | -      | CLOSE  | REMOTE | -     | -     |
|   | bit 7   | bit 6                              | bit 5     | bit 4  | bit 3  | bit 2  | bit 1 | bit 0 |
|   | -   | -                                  | WAIT_ TRG | SCAN   | -      | -      | -     | -     |
| <b>Example</b>  | : <b>STAT:OPER:EVEN?</b><br>1024<br>The device is in the remote state.  |                                    |           |        |        |        |       |       |
| <b>Note</b>   | <ul style="list-style-type: none"> <li>When an event occurs, 1 is set for the bit corresponding to each event and retained.</li> <li>The bit is not cleared until *<b>CLS</b> or this query is executed or the power is turned on again.</li> </ul> |                                    |           |        |        |        |       |       |

| Set and query Enable Register of Standard Operation Register Group |  |  |           |        |        |        |       |       |
|--|--|--|-----------|--------|--------|--------|-------|-------|
| <b>Syntax</b>  | Command  | : <b>STATus:OPERation:ENABLE</b> <0-65535 (NR1)> |           |        |        |        |       |       |
|  | Query  | : <b>STATus:OPERation:ENABLE?</b>                |           |        |        |        |       |       |
|  | Response   | <0 to 65535 (NR1)>                               |           |        |        |        |       |       |
| <b>Description</b>   | Sets the SRER mask pattern to a value from 0 to 255. The value when the device is turned on is 0. When issued as a query, unused bits are always set to 0. |  |           |        |        |        |       |       |
|  | bit 15   | bit 14   | bit 13    | bit 12 | bit 11 | bit 10 | bit 9 | bit 8 |
|  | -  | -  | ERR       | -      | CLOSE  | REMOTE | -     | -     |
|  | bit 7  | bit 6  | bit 5     | bit 4  | bit 3  | bit 2  | bit 1 | bit 0 |
|  | -  | -  | WAIT_ TRG | SCAN   | -      | -      | -     | -     |
| <b>Note</b>  | The initial value when the power is turned on is 0.  |  |           |        |        |        |       |       |

| Query Condition Register of Status Query Register Group |  |                                 |        |        |        |        |       |           |
|---|--|---------------------------------|--------|--------|--------|--------|-------|-----------|
| <b>Syntax</b>   | Query  | :STATus:QUESTionable:CONDition? |        |        |        |        |       |           |
|   | Response   | <0 to 65535 (NR1)>              |        |        |        |        |       |           |
| <b>Description</b>                                      | Returns the present status query register value. Unused bits (indicated in the following chart by “–”) return the value 0.   |                                 |        |        |        |        |       |           |
|   | bit 15   | bit 14                          | bit 13 | bit 12 | bit 11 | bit 10 | bit 9 | bit 8     |
|   | –  | –                               | –      | –      | –      | –      | –     | INFO_ ERR |
|   | bit 7  | bit 6                           | bit 5  | bit 4  | bit 3  | bit 2  | bit 1 | bit 0     |
|   | BACKUP_ ERR  | –                               | –      | –      | –      | –      | –     | –         |
| <b>Example</b>  | :STAT:QUES:COND?<br>128<br>Backup error is occurring.  |                                 |        |        |        |        |       |           |
| <b>Note</b>   | <ul style="list-style-type: none"> <li>The present status is returned when this command is received.</li> <li>Unlike :STATus:QUESTionable:EVENT?, :STATus:QUESTionalbe?, bit information is not retained.</li> </ul> |                                 |        |        |        |        |       |           |

| Query Event Register of Status Query Register Group |  |                               |        |        |        |        |       |           |
|---|--|-------------------------------|--------|--------|--------|--------|-------|-----------|
| <b>Syntax</b>                                       | Query  | :STATus:QUESTionable[:EVENT]? |        |        |        |        |       |           |
|   | Response   | <0 to 65535 (NR1)>            |        |        |        |        |       |           |
| <b>Description</b>                                  | Returns the retained status query register value. Unused bits (indicated in the following chart by “–”) return the value 0.  |                               |        |        |        |        |       |           |
|   | bit 15   | bit 14                        | bit 13 | bit 12 | bit 11 | bit 10 | bit 9 | bit 8     |
|   | –  | –                             | –      | –      | –      | –      | –     | INFO_ ERR |
|   | bit 7  | bit 6                         | bit 5  | bit 4  | bit 3  | bit 2  | bit 1 | bit 0     |
|   | BACKUP_ ERR  | –                             | –      | –      | –      | –      | –     | –         |
| <b>Example</b>                                      | :STAT:QUES?<br>256<br>A hardware information error has occurred.   |                               |        |        |        |        |       |           |
| <b>Note</b>   | <ul style="list-style-type: none"> <li>When an event occurs, 1 is set for the bit corresponding to each event and retained.</li> <li>The bit is not cleared until *CLS or this query is executed or the power is turned on again.</li> </ul> |                               |        |        |        |        |       |           |

| Set and query Enable Register of Status Query Register Group |   |  |        |        |        |        |       |           |
|--|---|--|--------|--------|--------|--------|-------|-----------|
| <b>Syntax</b>  | Command   | :STATus:QUESTionable:ENABLE <0–65535 (NR1) > |        |        |        |        |       |           |
|  | Query   | :STATus:QUESTionable:ENABLE?                 |        |        |        |        |       |           |
|  | Response  | <0 to 65535 (NR1)>                           |        |        |        |        |       |           |
| <b>Description</b>   | Sets the standard operation register mask pattern to a value from 0 to 65535. The value when the device is turned on is 0. When issued as a query, unused bits are always set to 0. |  |        |        |        |        |       |           |
|  | bit 15  | bit 14                                       | bit 13 | bit 12 | bit 11 | bit 10 | bit 9 | bit 8     |
|  | –   | –  | –      | –      | –      | –      | –     | INFO_ ERR |
|  | bit 7   | bit 6  | bit 5  | bit 4  | bit 3  | bit 2  | bit 1 | bit 0     |
|  | BACKUP_ ERR   | –  | –      | –      | –      | –      | –     | –         |
| <b>Note</b>  | The initial value when the power is turned on is 0.   |  |        |        |        |        |       |           |

(2) Connection method

| Set and query connection method |  |   |                           |                             |                  |                   |                         |
|---------------------------------|--|---|---------------------------|-----------------------------|------------------|-------------------|-------------------------|
| <b>Syntax</b>                   | Command  | :SYSTem:MODule:WIRE:MODE <Slot No.>,<Connection method>   |                           |                             |                  |                   |                         |
|                                 | Query  | :SYSTem:MODule:WIRE:MODE? Slot No.>   |                           |                             |                  |                   |                         |
|                                 | Response   | <Connection method><br><Slot No.> = 1 - 3 (NR1) (SW1001)<br>1 - 12 (NR1) (SW1002)<br><Connection method> = WIRE2/WIRE4/TP4<br>WIRE2: 2-wire<br>WIRE4: 4-wire<br>TP4: 4-terminal |                           |                             |                  |                   |                         |
| <b>Description</b>              | Sets the connection method for each slot. Connection method selection determines the connection terminal for the instrument to which each channel is connected. The connection method settings vary depending on the module type. When the connection method is set, all relay is opened.  |   |                           |                             |                  |                   |                         |
| <b>Module</b>                   | <b>Parameter that can be set</b>   | <b>Connection method</b>  | <b>Number of channels</b> | <b>Instrument example</b>   | <b>Model</b>     | <b>Terminal</b>   | <b>Connection cable</b> |
| SW9001                          | WIRE2  | 2-wire  | 22                        | Voltmeter                   | DM7276           | <b>TERMINAL 1</b> | L4930                   |
|                                 | WIRE4  | 4-wire  | 11                        | Battery tester              | BT3562           | <b>TERMINAL 2</b> | L2108                   |
| SW9002                          | WIRE2  | 2-wire  | 6                         | Voltmeter                   | DM7276           | <b>TERMINAL 1</b> | L4930                   |
|                                 | TP4  | 4-terminal pair   | 6                         | Battery tester<br>LCR meter | BT4560<br>IM3590 | <b>TERMINAL 3</b> | L2004                   |
| <b>Example</b>                  | <pre> :SYST:MOD:WIRE:MODE 1,WIRE2 Set the connection method for <b>SLOT 1</b> to 2-wire (use <b>TERMINAL 1</b> for measurement). :SYST:MOD:WIRE:MODE 12,TP4 Set the connection method for <b>SLOT 12</b> to 4-terminal pair (use <b>TERMINAL 3</b> for measurement). :SYST:MOD:WIRE:MODE? 5 <b>WIRE4</b> The connection method for <b>SLOT 5</b> is 4-wire.                     </pre> |   |                           |                             |                  |                   |                         |
| <b>Note</b>                     | <ul style="list-style-type: none"> <li>• When the connection method is selected, the shield switching is set to the specified value. Set the shield switching as necessary.</li> <li>• Specifying a slot without a module will result in an execution error.</li> <li>• An execution error occurs during scan operation (command).</li> </ul>  |   |                           |                             |                  |                   |                         |

(3) Shield switching

| Set and query the shield switching |  |  |                           |                                 |        |     |               |     |     |           |                                  |           |   |           |   |      |  |        |     |               |     |     |           |                                  |           |   |
|------------------------------------|--|--|---------------------------|---------------------------------|--------|-----|---------------|-----|-----|-----------|----------------------------------|-----------|---|-----------|---|------|--|--------|-----|---------------|-----|-----|-----------|----------------------------------|-----------|---|
| <b>Syntax</b>                      | Command  | <code>:SYSTem:MODUle:SHIEld &lt;Slot No.&gt;,&lt;Shield wire connection destination&gt;</code>   |                           |                                 |        |     |               |     |     |           |                                  |           |   |           |   |      |  |        |     |               |     |     |           |                                  |           |   |
|                                    | Query  | <code>:SYSTem:MODUle:SHIEld? Slot No.&gt;</code>   |                           |                                 |        |     |               |     |     |           |                                  |           |   |           |   |      |  |        |     |               |     |     |           |                                  |           |   |
|                                    | Response   | <p>&lt;Shield wire connection destination&gt;<br/>                     &lt;Slot No.&gt; = 1 - 3 (NR1) (SW1001)<br/>                     1 - 12 (NR1) (SW1002)<br/>                     &lt;Shield wire connection destination&gt; = OFF/GND/TERMinal1/<br/>                     TERMinal2/TERMinal3/T1T3/SNS2L<br/>                     OFF: Not connected<br/>                     GND: Connected to ground<br/>                     TERMinal1: <b>TERMINAL 1</b>, connect to LOW terminal<br/>                     TERMinal2: <b>TERMINAL 2, TERMINAL 3</b>, connect to source LOW terminal<br/>                     TERMinal3: <b>TERMINAL 3</b>, connect to sense shield terminal<br/>                     T1T3: <b>TERMINAL 1</b>, LOW terminal + <b>TERMINAL 3</b>, connect to sense shield terminal</p> |                           |                                 |        |     |               |     |     |           |                                  |           |   |           |   |      |  |        |     |               |     |     |           |                                  |           |   |
| <b>Description</b>                 | <p>Sets the shield wire connection destination for each slot.<br/>                     The settings vary depending on the module type.<br/>                     When the shield switching is set, all relay is opened.</p> <table border="1"> <thead> <tr> <th>Module</th> <th>Parameter that can be set</th> <th>Connection destination terminal</th> </tr> </thead> <tbody> <tr> <td rowspan="6">SW9001</td> <td>Off</td> <td>Not connected</td> </tr> <tr> <td>GND</td> <td>GND</td> </tr> <tr> <td>TERMinal1</td> <td><b>TERMINAL 1</b>, LOW terminal</td> </tr> <tr> <td>TERMinal2</td> <td><b>TERMINAL 2, TERMINAL 3</b>, source LOW terminal</td> </tr> <tr> <td>TERMinal3</td> <td><b>TERMINAL 3</b>, sense shield terminal</td> </tr> <tr> <td>T1T3</td> <td>TERMINAL 1, LOW terminal + TERMINAL 3, sense shield terminal</td> </tr> <tr> <td rowspan="4">SW9002</td> <td>Off</td> <td>Not connected</td> </tr> <tr> <td>GND</td> <td>GND</td> </tr> <tr> <td>TERMinal1</td> <td><b>TERMINAL 1</b>, LOW terminal</td> </tr> <tr> <td>TERMinal3</td> <td><b>TERMINAL 3</b>, sense shield terminal</td> </tr> </tbody> </table> | Module   | Parameter that can be set | Connection destination terminal | SW9001 | Off | Not connected | GND | GND | TERMinal1 | <b>TERMINAL 1</b> , LOW terminal | TERMinal2 | <b>TERMINAL 2, TERMINAL 3</b> , source LOW terminal | TERMinal3 | <b>TERMINAL 3</b> , sense shield terminal | T1T3 | TERMINAL 1, LOW terminal + TERMINAL 3, sense shield terminal | SW9002 | Off | Not connected | GND | GND | TERMinal1 | <b>TERMINAL 1</b> , LOW terminal | TERMinal3 | <b>TERMINAL 3</b> , sense shield terminal |
| Module                             | Parameter that can be set  | Connection destination terminal  |                           |                                 |        |     |               |     |     |           |                                  |           |   |           |   |      |  |        |     |               |     |     |           |                                  |           |   |
| SW9001                             | Off  | Not connected  |                           |                                 |        |     |               |     |     |           |                                  |           |   |           |   |      |  |        |     |               |     |     |           |                                  |           |   |
|                                    | GND  | GND  |                           |                                 |        |     |               |     |     |           |                                  |           |   |           |   |      |  |        |     |               |     |     |           |                                  |           |   |
|                                    | TERMinal1  | <b>TERMINAL 1</b> , LOW terminal   |                           |                                 |        |     |               |     |     |           |                                  |           |   |           |   |      |  |        |     |               |     |     |           |                                  |           |   |
|                                    | TERMinal2  | <b>TERMINAL 2, TERMINAL 3</b> , source LOW terminal  |                           |                                 |        |     |               |     |     |           |                                  |           |   |           |   |      |  |        |     |               |     |     |           |                                  |           |   |
|                                    | TERMinal3  | <b>TERMINAL 3</b> , sense shield terminal  |                           |                                 |        |     |               |     |     |           |                                  |           |   |           |   |      |  |        |     |               |     |     |           |                                  |           |   |
|                                    | T1T3   | TERMINAL 1, LOW terminal + TERMINAL 3, sense shield terminal   |                           |                                 |        |     |               |     |     |           |                                  |           |   |           |   |      |  |        |     |               |     |     |           |                                  |           |   |
| SW9002                             | Off  | Not connected  |                           |                                 |        |     |               |     |     |           |                                  |           |   |           |   |      |  |        |     |               |     |     |           |                                  |           |   |
|                                    | GND  | GND  |                           |                                 |        |     |               |     |     |           |                                  |           |   |           |   |      |  |        |     |               |     |     |           |                                  |           |   |
|                                    | TERMinal1  | <b>TERMINAL 1</b> , LOW terminal   |                           |                                 |        |     |               |     |     |           |                                  |           |   |           |   |      |  |        |     |               |     |     |           |                                  |           |   |
|                                    | TERMinal3  | <b>TERMINAL 3</b> , sense shield terminal  |                           |                                 |        |     |               |     |     |           |                                  |           |   |           |   |      |  |        |     |               |     |     |           |                                  |           |   |
| <b>Example</b>                     | <p><code>:SYST:MOD:SHI 1,GND</code><br/>                     Connect the shield wire for <b>SLOT 1</b> to GND.<br/> <code>:SYST:MOD:WIRE:MODE? 5</code><br/> <b>OFF</b><br/>                     The shield wire for <b>SLOT 5</b> is not connected.</p>   |  |                           |                                 |        |     |               |     |     |           |                                  |           |   |           |   |      |  |        |     |               |     |     |           |                                  |           |   |
| <b>Note</b>                        | <ul style="list-style-type: none"> <li>When the connection method is selected, the shield switching is set to the specified value. Set the shield switching again as necessary.</li> <li>The [<b>TERMINAL 1</b>, LOW terminal + <b>TERMINAL 3</b>, sense shield terminal (T1T3)] shielding connection on the SW9001 should only be used when connecting a BT3562 and DM7275/DM7276 at the same time while the DM7275/DM7276 contact check function is not operating properly.</li> <li>Specifying a slot without a module will result in an execution error.</li> <li>An execution error occurs during scan operation (command).</li> </ul>  |  |                           |                                 |        |     |               |     |     |           |                                  |           |   |           |   |      |  |        |     |               |     |     |           |                                  |           |   |

(4) Selecting the channel

| Select and query channel |   |  |
|--------------------------|---|--|
| Syntax                   | Command   | [ROUTE]: CLOSe <Slot and channel No.>  |
|                          | Query   | [ :ROUTE ] :CLOSe?   |
|                          | Response  | <Slot and channel No.><br><Slot and channel No.> = Slot No. × 100 + CH No.<br>A 3-digit number (or 4-digit number) is used to specify the channel.<br>Example: 208 (or 0208) when specifying channel 8 for <b>SLOT 2</b> .<br>1112 when specifying channel 12 for <b>SLOT 11</b> . |
| Description              | Closes the specified slot and channel. The channel that was closed previously is automatically opened. You can use the *OPC? query to check whether close operation has completed.              |  |
| Example                  | :CLOS 0122<br>Channel 22 for <b>SLOT 1</b> is closed.<br>:CLOS?<br>905<br>Channel 5 for <b>SLOT 9</b> is closed.  |  |
| Note                     | <ul style="list-style-type: none"> <li>• Specifying a slot without a module will result in an execution error.</li> <li>• An execution error occurs during scan operation (command).</li> </ul> |  |

| Open all relays |  |                  |
|-----------------|--|------------------|
| Syntax          | Command  | [ :ROUTE ] :OPEN |
| Description     | Opens all channels. You can use the *OPC? query to check whether close operation has completed.                      |                  |
| Example         | Command  | :OPEN            |
| Note            | Executing this command while scan operation is in progress will cause scan operation to stop and all relays to open. |                  |

| Set and query channel delay time |  |   |
|----------------------------------|--|---|
| Syntax                           | Command  | :SYSTem:MODule:DElAy <Slot No.>,<Time/MIN/MAX/DEF>  |
|                                  | Query  | :SYSTem:MODule:DElAy? Slot No.>   |
|                                  | Response   | <Time><br><Slot No.> = 1 to 3 (NR1) (SW1001)<br>1 to 12 (NR1) (SW1002)<br><Time> = 0 to 9.999 (NR2) [s] (MIN:0, MAX: 9.999, DEF: 0) |
| Description                      | Sets the additional delay time after relay operation (standby for the specified settling time occurs).<br>After the delay time elapses, channel closing is completed.<br>The channel delay time can be specified for each slot |   |
| Example                          | :SYSTem:MODule:DElAy 1,0.01<br>Set the channel delay time for <b>SLOT 1</b> to 0.01 s.<br>:SYSTem:MODule:DElAy? 3<br>0.5<br>The channel delay time for <b>SLOT 3</b> has been set to 0.5 s.                                    |   |
| Note                             | <ul style="list-style-type: none"> <li>• Specifying a slot without a module will result in an execution error.</li> <li>• An execution error occurs during scan operation (command).</li> </ul>                                |   |

(5) Scan Function

| Register and query scan list |  |   |
|------------------------------|--|---|
| <b>Syntax</b>                | Command  | <code>[ :ROUTE ] :SCAN&lt; (@Channel list) &gt;</code>  |
|                              | Query  | <code>[ :ROUTE ] :SCAN?</code>  |
|                              | Response   | <(@Channel list)><br>Specify the channel list in the following formats.<br><CH>,<CH>, ..., <CH> Specify the channels to be measured individually.<br><CHm>:<CHn> Specify from CHm to CHn consecutively. |
| <b>Description</b>           | Registers the scan function scan list (channel list to be switched). Specify the channel using the combined number of the slot number and channel number inside the module <Slot No.> × 100 + channel number inside the module). Up to 1000 channels can be registered for the scan list. (@) can be omitted.  |   |
| <b>Example</b>               | <code>:SCAN (@101,102,103,201,202)</code><br>Scanning is performed in order of 101, 102, 103, 201, and then 202.<br><code>:SCAN (@101:312)</code><br>Scanning is performed from 101 to 312.<br><code>:SCAN 1001:1222</code><br>Scanning is performed from 1001 to 1222.<br><code>:SCAN?</code><br><code>(@101,102,103,201,202)</code><br>Scanning is set to be performed in order of 101, 102, 103, 201, and then 202. |   |
| <b>Note</b>                  | An execution error occurs during scan operation (command).   |   |

| Adding to the scan list |  |   |
|-------------------------|--|---|
| <b>Syntax</b>           | Command  | <code>[ :ROUTE ] :SCAN:ADD &lt; (@Channel list) &gt;</code>   |
|                         |  | <(@Channel list)><br>Specify the channel list in the following formats.<br><CH>,<CH>, ..., <CH> Specify the channels to be measured individually.<br><CHm>:<CHn> Specify from CHm to CHn consecutively. |
| <b>Description</b>      | Adds a list of channels to the end of the present scan list. A total of up to 1000 channels may be registered. Attempting to add 200 channels if there are presently 900 channels registered will result in an error, leaving the original scan list of 900 channels (none of the 200 channels will be added). You can check the number of channels that can be added by using the <code>:SCAN:SIZE?</code> query. |   |
| <b>Example</b>          | <code>:SCAN 101,102</code><br><code>:SCAN:ADD 201,202</code><br>Scan list is 101, 102, 201, and 202.   |   |
| <b>Note</b>             | An execution error occurs during scan operation (command).   |   |

| Delete scan list   |  |                                      |
|--------------------|--|--------------------------------------|
| <b>Syntax</b>      | Command  | <code>[ :ROUTE ] :SCAN:REMOVe</code> |
| <b>Description</b> | Deletes the scan list.                                     |                                      |
| <b>Example</b>     | <code>:SCAN:REM</code><br>The scan list is deleted.        |                                      |
| <b>Note</b>        | An execution error occurs during scan operation (command). |                                      |

| Query the number of scan lists that can be added. |   |                                     |
|---|---|-------------------------------------|
| Syntax  | Query   | <code>[ :ROUTE ] :SCAN:SIZE?</code> |
|   | Response  | 0 to 1000 (NR1)                     |
| Description                                       | Checks the number of channels (remaining) that can be added to the scan list. Up to 1000 scan lists can be registered.    |                                     |
| Example   | <pre> :SCAN 101 :SCAN:SIZE? 999                     </pre> The remaining number is 999 after one scan list is registered. |                                     |

| Scan operation reset |   |                     |
|----------------------|---|---------------------|
| Syntax               | Command   | <code>:ABORt</code> |
| Description          | Resets the scan operation. Channels are opened. |                     |

| Set and query scan operation trigger source |   |  |
|---|---|--|
| Syntax                                      | Command   | <code>:TRIGger:SOURce &lt;STEP&gt;</code>  |
|   | Query   | <code>:TRIGger:SOURce?</code>  |
|   | Response  | <STEP><br>Scanning is performed with the SCAN signal of EXT. I/O or the *TRG command. The step is incremented with each input of the *TRG command or EXT. I/O SCAN signal. |
| Description                                 | Sets the trigger source for scan operation.   |  |
| Example                                     | <pre> :TRIG:SOUR STEP                     </pre> This setting configures scan operation in which the step is incremented with each trigger input. <pre> :TRIG:SOUR? STEP                     </pre> |  |
| Note  | An execution error occurs during scan operation (command).  |  |

| Query and clear error information |   |  |
|-----------------------------------|---|--|
| Syntax                            | Query   | <code>:SYSTem:ERRor?</code>  |
|                                   | Response  | <Error No.>,<"Error message"><br><Error No.> = Negative value error number (NR1)<br><"Error message"> (use double quotation marks for the character string.) |
| Description                       | Returns and clears the error if any. Errors are in ERR bit 2 of the Status Byte Register (STB). When an error occurs, the ERR bit of the STB is set until the error is read by this command or *CLS is executed. When there is no error, the error No. and an empty message " " are returned. See: "10.2 List of Device Error Numbers" (p. 127) |  |
| Example                           | <pre> :SYST:ERR? -100, "Command error"                     </pre>   |  |

## (6) Command forwarding function

| Set and query RS-232C communication speed of the communication command forwarding function |  |  |
|--|--|--|
| Syntax   | Command  | <code>:SYSTem:COMMunicate:FORWard:RS232C:SPEED<br/>&lt;9600/19200/38400&gt;</code> |
|  | Query  | <code>:SYSTem:COMMunicate:FORWard:RS232C:SPEED?</code>                             |
|  | Response   | <9600/19200/38400>   |
| Description  | Set the communication speed of the RS-232C (communication command forwarding function). The speed setting is immediately changed.<br>Other RS-232C communication parameters are fixed to 8 for data bit length, 1 for stop bit, None for parity check, and None for flow control |  |
| Note   | An execution error occurs during scan operation (command).   |  |

| Set and query forward timeout period |  |   |
|--------------------------------------|--|---|
| Syntax                               | Command  | <code>:SYSTem:COMMunicate:FORWard:TIMEout &lt;1-100/MIN/MAX/<br/>DEF&gt;</code> |
|                                      | Query  | <code>:SYSTem:COMMunicate:FORWard:TIMEout?</code>                               |
|                                      | Response   | <1 to 100 (NR1)> [s] (MIN: 1, MAX: 100, DEF: 10)                                |
| Description                          | Sets the communication timeout period for a response when a query is forwarded.  |   |
| Example                              | <pre> :SYST:COMM:FORW:TIM 5 Set the query forward timeout period to 5 seconds. :SYST:COMM:FORW:TIM? 30 The query forward timeout period has been set to 30 seconds. </pre> |   |

| Transfer command or query to forward destination A |  |  |
|--|--|--|
| Syntax   | Command  | <code>:A &lt;"Forward character string"&gt;</code> |
|  | Response   | <Response character string>                        |
| Description  | Transfers the command or query to the instrument through the RS-232C port for the instrument. In case of a query, a response from the forward destination is received and returned to the PC. Or " <code>:A</code> " can also be added (without a space) to the start of the forward character string.                       |  |
| Example  | <pre> :A ":FUNC RV" The :FUNC RV command is forwarded to forward destination A. :A ":READ?" 289.68E-3, 1.3921E+0 The :READ? query is forwarded to forward destination A and the response is received and returned to the PC. Command or query forward can also be performed in the following format. :A:INIT :A:READ? </pre> |  |



(7) EXT. I/O settings

| Set and query EXT. I/O input terminal filter funcio |   |  |
|---|---|--|
| Syntax  | Command   | <code>:IO:FILTer:STATe &lt;1/0/ON/OFF&gt;</code>                         |
|   | Query   | <code>:IO:FILTer:STATe?</code>   |
|   | Response  | <1/0><br>1/ON The filter is activated<br>0/OFF The filter is deactivated |
| Description   | Sets whether to activate or deactivate the filter function to prevent chattering for the SCAN of EXT. I/O and SCAN_RESET input terminal.                |  |
| Example   | <code>:IO:FILT:STAT 1</code><br>The filter function is activated<br><code>:IO:FILT:STAT?</code><br><code>0</code><br>The filter function is deactivated |  |
| Note  | An execution error occurs during scan operation (command).  |  |

| Set and query EXT. I/O input terminal filter tim |  |  |
|--|--|--|
| Syntax   | Command  | <code>:IO:FILTer:TIME &lt;0.05-0.50/MIN/MAX/DEF&gt;</code> |
|  | Query  | <code>:IO:FILTer:TIME?</code>                              |
|  | Response   | <0.05 to 0.50 (NR2)> [s] (MIN:0.05, MAX: 0.50, DEF: 0.05)  |
| Description                                      | Sets the filter time   |  |
| Example  | <code>:IO:FILT:TIME 0.1</code><br>Set the filter time to 0.1 s<br><code>:IO:FILT:TIME?</code><br><code>0.05</code><br>The filter time has been set to 0.05 s |  |
| Note   | An execution error occurs during scan operation (command).   |  |

| Set and query CLOSE signal pulse width |  |  |
|--|--|--|
| Syntax                                 | Command  | <code>:IO:PULSe:TIME &lt;0.001-0.100/MIN/MAX/DEF&gt;</code>        |
|  | Query  | <code>:IO:PULSe:TIME?</code>                                       |
|  | Response   | <0.001 to 0.100 (NR2)> [s]<br>(MIN: 0.001, MAX: 0.100, DEF: 0.005) |
| Description                            | Sets the pulse width of the EXT. I/O CLOSE signal.   |  |
| Example                                | <code>:IO:PULS:TIME 0.001</code><br>Set the pulse width of the CLOSE signal to 0.001 s.<br><code>:IO:PULS:TIME?</code><br><code>0.005</code><br>The pulse width of the CLOSE signal has been set to 0.005 s. |  |
| Note                                   | An execution error occurs during scan operation (command).   |  |

(8) RS-232C settings

| Set and query RS-232C communication speed |  |   |
|---|--|---|
| Syntax                                    | Command  | :SYSTem:COMMunicate:RS232C:SPEED <9600/19200/38400> |
|   | Query  | :SYSTem:COMMunicate:RS232C:SPEED?                   |
|   | Response   | <9600/19200/38400>                                  |
| Description                               | <p>Sets the RS-232C communication speed. The speed setting is immediately changed. When the communication setting mode switch (<b>DFLT/USER</b>) is set to <b>DFLT</b>, the speed setting is fixed to 9600 bps regardless of the settings specified her</p> <p>The query returns the set value regardless of the communication setting mode switch state.</p> <p>Other RS-232C communication parameters are fixed to data bits: 8; stop bit: 1; parity check: none; flow control: none</p> |   |
| Note                                      | An execution error occurs during scan operation (command).   |   |

(9) LAN settings

| Set and query communication command port No. |   |  |
|--|---|--|
| Syntax                                       | Command   | :SYSTem:COMMunicate:LAN:CONTRol <1-9999> |
|  | Query   | :SYSTem:COMMunicate:LAN:CONTRol?         |
|  | Response  | <1 to 9999 (NR1)>                        |
| Description                                  | <p>Specifies the TCP/IP port where communication commands are received via LAN. The setting is enabled after :SYSTem:COMMunicate:LAN:UPDate (or restart) is executed. When the communication setting mode switch (<b>DFLT/USER</b>) is set to <b>DFLT</b>, the port No. is fixed to 23 regardless of the settings specified her</p> <p>The query returns the set value regardless of the communication setting mode switch state.</p> |  |
| Example                                      | <pre>SYST:COMM:LAN:CONT 23 SYST:COMM:LAN:UPD SYST:COMM:LAN:CONT? 23</pre>   |  |
| Note   | An execution error occurs during scan operation (command).  |  |

| Set and query default gateway |   |  |
|-------------------------------|---|--|
| Syntax                        | Command   | :SYSTem:COMMunicate:LAN:GATeway <Value 1>,<Value 2>,<Value 3>,<Value 4>  |
|                               | Query   | :SYSTem:COMMunicate:LAN:GATeway?   |
|                               | Response  | <p>&lt;Value 1&gt;,&lt;Value 2&gt;,&lt;Value 3&gt;,&lt;Value 4&gt;</p> <p>&lt;Value 1&gt; = 0 to 255 (NR1)</p> <p>&lt;Value 2&gt; = 0 to 255 (NR1)</p> <p>&lt;Value 3&gt; = 0 to 255 (NR1)</p> <p>&lt;Value 4&gt; = 0 to 255 (NR1)</p> <p>&lt;Value 1&gt; to &lt;Value 4&gt; indicate the address.</p> |
| Description                   | <p>Sets the default gateway address. The setting is enabled after :SYSTem:COMMunicate:LAN:UPDate (or restart) is executed. When the communication setting mode switch (<b>DFLT/USER</b>) is set to <b>DFLT</b>, the address is fixed to 0.0.0.0 (none) regardless of the settings specified her</p> <p>The query returns the set value regardless of the communication setting mode switch state.</p> |  |
| Example                       | <pre>SYST:COMM:LAN:GAT 192,168,0,100 SYST:COMM:LAN:UPD SYST:COMM:LAN:GAT? 192,168,0,100</pre>   |  |
| Note                          | An execution error occurs during scan operation (command).  |  |

| Set and query IP address |   |   |
|--------------------------|---|---|
| Syntax                   | Command   | <code>:SYSTem:COMMunicate:LAN:IPADdress &lt;Value 1&gt;,&lt;Value 2&gt;,&lt;Value 3&gt;,&lt;Value 4&gt;</code>  |
|                          | Query   | <code>:SYSTem:COMMunicate:LAN:IPADdress?</code>   |
|                          | Response  | <p>&lt;Value 1&gt;,&lt;Value 2&gt;,&lt;Value 3&gt;,&lt;Value 4&gt;<br/>                     &lt;Value 1&gt; = 0 to 255 (NR1)<br/>                     &lt;Value 2&gt; = 0 to 255 (NR1)<br/>                     &lt;Value 3&gt; = 0 to 255 (NR1)<br/>                     &lt;Value 4&gt; = 0 to 255 (NR1)<br/>                     &lt;Value 1&gt; to &lt;Value 4&gt; indicate the IP address.</p> |
| Description              | <p>Set the IP address for the device.<br/>                     The setting is enabled after <code>:SYSTem:COMMunicate:LAN:UPDate</code> (or restart) is executed.<br/>                     When the communication setting mode switch (<b>DFLT/USER</b>) is set to <b>DFLT</b>, the address is fixed to 192.168.0.254 regardless of the settings specified her<br/>                     The query returns the set value regardless of the communication setting mode switch state.<br/>                     When the LAN function is set to off, 0,0,0,0 is returned.</p> |   |
| Example                  | <pre>SYST:COMM:LAN:IPAD 192,168,0,2 SYST:COMM:LAN:UPD SYST:COMM:LAN:IPAD? 192,168,0,2</pre>   |   |
| Note                     | <ul style="list-style-type: none"> <li>• When connecting to the existing network, specify the LAN settings via USB or RS-232C in advance. If a wrong IP address or overlapping IP address is used, a problem may arise with the existing network.</li> <li>• An execution error occurs during scan operation (command).</li> </ul>  |   |

| Set and query subnet mask |  |   |
|---------------------------|--|---|
| Syntax                    | Command  | <code>:SYSTem:COMMunicate:LAN:SMASK &lt;Value 1&gt;,&lt;Value 2&gt;,&lt;Value 3&gt;,&lt;Value 4&gt;</code>  |
|                           | Query  | <code>:SYSTem:COMMunicate:LAN:SMASK?</code>   |
|                           | Response   | <p>&lt;Value 1&gt;,&lt;Value 2&gt;,&lt;Value 3&gt;,&lt;Value 4&gt;<br/>                     &lt;Value 1&gt; = 0 to 255 (NR1)<br/>                     &lt;Value 2&gt; = 0 to 255 (NR1)<br/>                     &lt;Value 3&gt; = 0 to 255 (NR1)<br/>                     &lt;Value 4&gt; = 0 to 255 (NR1)<br/>                     &lt;Value 1&gt; to &lt;Value 4&gt; indicate the mask value.</p> |
| Description               | <p>Set the LAN subnet mask.<br/>                     The setting is enabled after <code>:SYSTem:COMMunicate:LAN:UPDate</code> (or restart) is executed.<br/>                     When the communication setting mode switch (<b>DFLT/USER</b>) is set to <b>DFLT</b>, the address is fixed to 255.255.255.0 regardless of the settings specified her<br/>                     The query returns the set value regardless of the communication setting mode switch state.</p> |   |
| Example                   | <pre>SYST:COMM:LAN:SMAS 255,255,255,0 SYST:COMM:LAN:UPD SYST:COMM:LAN:IPAD? 255,255,255,0</pre>  |   |
| Note                      | <p>An execution error occurs during scan operation (command).</p>  |   |

| Apply LAN settings |  |                                |
|--------------------|--|--------------------------------|
| <b>Syntax</b>      | Command  | :SYSTem:COMMunicate:LAN:UPDate |
| <b>Description</b> | Update and apply the LAN settings.<br>When the communication setting mode switch ( <b>DFLT/USER</b> ) is set to <b>DFLT</b> , no operation is performed.<br>Any active connection via LAN is interrupted.  |                                |
| <b>Example</b>     | :SYST:COMM:LAN:IPAD 192,168,1,100<br>:SYST:COMM:LAN:SMAS 255,255,255,0<br>:SYST:COMM:LAN:GAT 0,0,0,0<br>:SYST:COMM:LAN:CONT 23<br>:SYST:COMM:LAN:UPD<br>For LAN-related settings, the IP address is set to 192.168.1.100, port No. 23, and gateway OFF and the settings are applied. |                                |
| <b>Note</b>        | An execution error occurs during scan operation (command).   |                                |

| Query MAC address  |   |                              |
|--------------------|---|------------------------------|
| <b>Syntax</b>      | Query                                     | :SYSTem:COMMunicate:LAN:MAC? |
|                    | Response                                  | <MAC address>                |
| <b>Description</b> | Returns the MAC address of the device.    |                              |
| <b>Example</b>     | SYST:COMM:LAN:MAC?<br>"00-01-67-00-00-00" |                              |

## (10) System information

| Backing up settings |   |                |
|---------------------|---|----------------|
| <b>Syntax</b>       | Command   | :SYSTem:BACKup |
| <b>Description</b>  | Stores the hardware settings in the device's internal non-volatile memory. Settings will be retained even when the power is turned off.   |                |
| <b>Note</b>         | <ul style="list-style-type: none"> <li>The non-volatile memory can be rewritten about 100,000 times. Avoid frequent use of this command.</li> <li>An execution error occurs during scan operation (command).</li> </ul> |                |

| Query slot module information |  |  |
|-------------------------------|--|--|
| <b>Syntax</b>                 | Query  | :SYSTem:CTYPe? <Slot No.>  |
|                               | Response   | <Manufacturer name>,<Model name>,<Serial No.><br><Slot No.> = 1 to 3 (NR1) (SW1001)<br>1 to 12 (NR1) (SW1002)<br><Manufacturer name> = HIOKI<br>0 (Not attached)<br><Model name> = SW9001 (SW9001)<br>SW9002 (SW9002)<br>0 (Not attached)<br><Serial No.> = Serial No. (NR1) |
| <b>Description</b>            | Returns the module information of the specified slot |  |
| <b>Example</b>                | :SYSTem:CTYPe? 1<br>HIOKI,SW9001,180612345           |  |

| Query relay opening/closing frequency |   |   |
|---------------------------------------|---|---|
| Syntax                                | Query   | :SYSTem:MODule:COUnT? <Slot No.> [,<Relay No.>]   |
|                                       | Response  | <Slot No.> = 1 to 3 (NR1) (SW1001)<br>1 to 12 (NR1) (SW1002)<br><Opening/closing frequency> = 0 to 1000000000 (NR1) |
| Description                           | Returns to the specified relay opening/closing frequenc .   |   |
| Example                               | :SYSTem:MODule:COUnT? 1<br>101257   |   |
| Note                                  | <ul style="list-style-type: none"> <li>The relay opening/closing frequency is saved in the non-volatile memory inside each module. If no relay number is specified, the query will return the count for the relay for the selected slot that has been turned off and on the most times. (See: p. 134, p. 140)</li> <li>Specifying a slot without a module will result in an execution error.</li> </ul> |   |

(11) Initialization

| Initialize the device |  |                                  |
|-----------------------|--|----------------------------------|
| Syntax                | Command  | :SYSTem:PRESet<br>:STATus:PRESet |
| Description           | Resets the device to its initial state.<br>See: "6.1 Initialization Settings" (p.47)<br>The operation is the same for :SYSTem:PRESet and :STATus:PRESet.   |                                  |
| Example               | :SYST:PRES   |                                  |
| Note                  | <ul style="list-style-type: none"> <li>The communication conditions are not initialized.</li> <li>All closed channels are opened.</li> <li>Initialized settings are not preserved when the power is turned off. To save initialized settings, execute the SYSTem:BACKup command.<br/>See: "Backing up settings" (p.105)</li> </ul> |                                  |

(12) Test

| Relay contact welding test |  |   |
|----------------------------|--|---|
| Syntax                     | Command  | :TEST:RELAyshort <Slot No.>,<Test item> |
|                            | <Slot No.> = 1 to 3 (NR1) (SW1001)<br>1 to 12 (NR1) (SW1002)<br><Test item> = CH/BUS/OPEN<br>CH:        Channel relay test<br>BUS:       Bus relay test<br>OPEN:     Open the relay after all test is finished |   |
| Description                | Execute relay contact welding test to each slot.<br>The test must be executed to both channel relay and bus relay.<br>For details, see "Checking for relay contact welding" (p.26)                             |   |
| Example                    | :TEST:RELAyshort 1,CH<br>Execute the test to channel relay of SLOT 1.  |   |

## 8.10 Sample Programs

This section introduces how to create programs using Visual Basic® 5.0, Visual Basic® 6.0, or Visual Basic® 2013.

### Using Visual Basic® 5.0 or 6.0

---

These sample programs are created with Visual Basic® 5.0 and 6.0.

The following are used for communication.

For RS-232C/USB communication: Visual Basic® Professional MS Comm

During communications, the terminator setting is supposed to be as follows.

RS-232C/USB: CR+LF

## RS-232C/USB communications (Using Visual Basic® Professional MS Comm)

### Using the DM7276 to perform scan measurement

Connect the SW1001 and DM7276 to their respective COM ports and perform scan measurement from CH1 to CH22 for **SLOT 1**.

The USB interface can be used to communicate with the device in the same manner as the RS-232C interface. Check the COM number for the USB connection in the device properties and use that number for communications. Communications speed has no meaning in the context of a USB connection.

```
'Scan measurement sample
Private Sub ScanSample1()
Dim unit_no As Integer
Dim ch_no As Integer
Dim ch_str As String
Dim recv_str As String

MSComm1.CommPort = 3                                'Connect the SW1001 to COM3.
MSComm1.Settings = "9600,n,8,1"
MSComm2.CommPort = 4                                'Connect the DM7276 to COM4.
MSComm2.Settings = "9600,n,8,1"
MSComm1.PortOpen = True
MSComm2.PortOpen = True

Open App.Path & "data.csv" For Output As #1          'Open a file for saving

SendCommand MSComm1, ":SYST:MOD:WIRE:MODE 1,WIRE2" 'Configure SLOT1 as a 2-wire connection
SendCommand MSComm1, "*OPC?"                        'Wait for the operation to complete.
ReceiveCOM MSComm1

For unit_no = 1 To 1
  For ch_no = 1 To 22
    ch_str = Format(unit_no, "00") & Format(ch_no, "00") 'Create a string to specify the channel.
    SendCommand MSComm1, ":CLOS " & ch_str             'Close the specified channel
    SendCommand MSComm1, "*OPC?"                       'Wait for the closing of the channel to complete.
    ReceiveCOM MSComm1
    SendCommand MSComm2, ":READ?"                     'Send the one-time measurement command to
                                                       'the DM7276.
    recv_str = ReceiveCOM(MSComm2)                    'Receive the measured value.
    Print #1, ch_str & ", " & recv_str                 'Write measurement data to a file
  Next
Next
SendCommand MSComm1, ":OPEN"                          'Open all relays after the scan completes.

Close #1
MSComm1.PortOpen = False
MSComm2.PortOpen = False
End Sub

'Send to the specified COM port
Private Sub SendCommand(comport As MSComm, cmdstr As String)
comport.InBufferCount = 0
comport.Output = cmdstr + vbCrLf
End Sub

'Receive from the specified COM port
Private Function ReceiveCOM(comport As MSComm) As String
Dim recvstr As String
Do While Right(recvstr, 1) <> Chr(10)
  recvstr = RecStr + comport.Input
  DoEvents
Loop
ReceiveCOM = Left(recvstr, Len(recvstr) - 2)
End Function
```

**Measure the internal resistance using the BT3562 and measure the OCV using the DM7276.**

Connect the SW1001 and BT3562, DM7276 to their respective COM ports and perform scan measurement of internal resistance and OCV from CH1 to CH11 for **SLOT 1**.

|  |   |
|--|---|
| 'Scan measurement sample<br>Private Sub ScanSample2()<br>Dim unit_no As Integer<br>Dim ch_no As Integer<br>Dim ch_str As String<br>Dim recv_str As String<br>Dim ir_str(50) As String<br>Dim ocv_str(50) As String<br>Dim i As Integer |   |
| MSComm1.CommPort = 3   | 'Connect the SW1001 to COM3.                          |
| MSComm1.Settings = "9600,n,8,1"  |   |
| MSComm2.CommPort = 4   | 'Connect the BT3562 to COM4.                          |
| MSComm2.Settings = "9600,n,8,1"  |   |
| MSComm3.CommPort = 5   | 'Connect the DM7276 to COM5.                          |
| MSComm3.Settings = "9600,n,8,1"  |   |
| MSComm1.PortOpen = True  |   |
| MSComm2.PortOpen = True  |   |
| MSComm3.PortOpen = True  |   |
| Open App.Path & "data.csv" For Output As #1  | 'Open a file for saving                               |
| SendCommand MSComm1, ":SYST:MOD:WIRE:MODE 1,WIRE4"   | 'Configure SLOT1 as a 4-wire connection               |
| SendCommand MSComm1, "*OPC?"   | 'Wait for the operation to complete.                  |
| ReceiveCOM MSComm1   |   |
| SendCommand MSComm2, ":INIT:CONT OFF"  | 'Turn off the continuous measurement of BT3562.       |
| i = 0  |   |
| For unit_no = 1 To 1   |   |
| For ch_no = 1 To 11  |   |
| ch_str = Format(unit_no, "00") & Format(ch_no, "00")   | 'Create a string to specify the channel.              |
| SendCommand MSComm1, ":CLOS " & ch_str   | 'Close the specified channel                          |
| SendCommand MSComm1, "*OPC?"   | 'Wait for the closing of the channel to complete.     |
| ReceiveCOM MSComm1   |   |
| SendCommand MSComm2, ":READ?"  | 'Send the one-time measurement command to the BT3562. |
| ir_str(i) = ReceiveCOM(MSComm2)  | 'Receive the measured value.                          |
| i = i + 1  |   |
| Next   |   |
| Next   |   |
| SendCommand MSComm1, ":SYST:MOD:WIRE:MODE 1,WIRE2"   | 'Configure SLOT1 as a 2-wire connection               |
| SendCommand MSComm1, "*OPC?"   | 'Wait for the operation to complete.                  |
| ReceiveCOM MSComm1   |   |
| i = 0  |   |
| For unit_no = 1 To 1   |   |
| For ch_no = 12 To 22   | 'The 2-wire CH12 corresponds to the 4-wire CH1 sense. |
| ch_str = Format(unit_no, "00") & Format(ch_no, "00")   | 'Create a string to specify the channel.              |
| SendCommand MSComm1, ":CLOS " & ch_str   | 'Close the specified channel                          |
| SendCommand MSComm1, "*OPC?"   | 'Wait for the closing of the channel to complete.     |
| ReceiveCOM MSComm1   |   |
| SendCommand MSComm3, ":READ?"  | 'Send the one-time measurement command to the DM7276. |
| ocv_str(i) = ReceiveCOM(MSComm3)   | 'Receive the measured value.                          |
| i = i + 1  |   |
| Next   |   |
| Next   |   |
| SendCommand MSComm1, ":OPEN"   | 'Open all relays after the scan completes.            |



```

'Write the CH1 to CH11 measurement data of SLOT 1 to a file
i = 0
For unit_no = 1 To 1
  For ch_no = 1 To 11
    ch_str = Format(unit_no, "00") & Format(ch_no, "00")
    Print #1, ch_str & "," & ir_str(i) & "," & ocv_str(i)
    i = i + 1
  Next
Next

Close #1
MSComm1.PortOpen = False
MSComm2.PortOpen = False
MSComm3.PortOpen = False
End Sub

'Send to the specified COM port
Private Sub SendCommand(comport As MSComm, cmdstr As String)
comport.InBufferCount = 0
comport.Output = cmdstr + vbCrLf
End Sub

'Receive from the specified COM port
Private Function ReceiveCOM(comport As MSComm) As String
Dim recvstr As String
Do While Right(recvstr, 1) <> Chr(10)
  recvstr = RecStr + comport.Input
  DoEvents
Loop
ReceiveCOM = Left(recvstr, Len(recvstr) - 2)
End Function

```

'Write measurement data to a file

## Using Visual Basic® 2013

This section describes how to use Visual Basic® 2013 Express Edition to operate the unit from a PC via an RS-232C or USB interface, import measured values, and save measured values to a file

The procedure may differ slightly from the one described here depending on the environment of the PC and Visual Basic® 2013. For a detailed explanation on how to use Visual Basic® 2013, refer to the instruction manual or Help feature of Visual Basic® 2013.

### (1) Creating a new project

**1** Startup Visual Basic® 2013.

**2** Select [File] – [New Project].

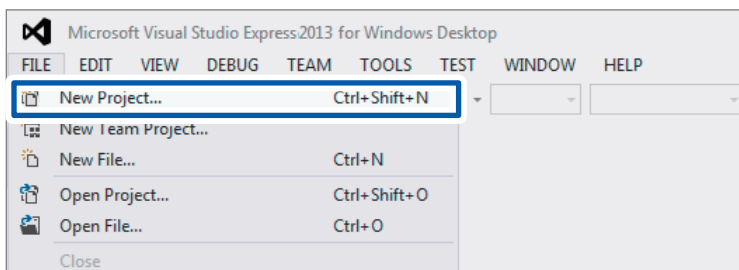

**3** Select [Windows Forms Application] from the templates.

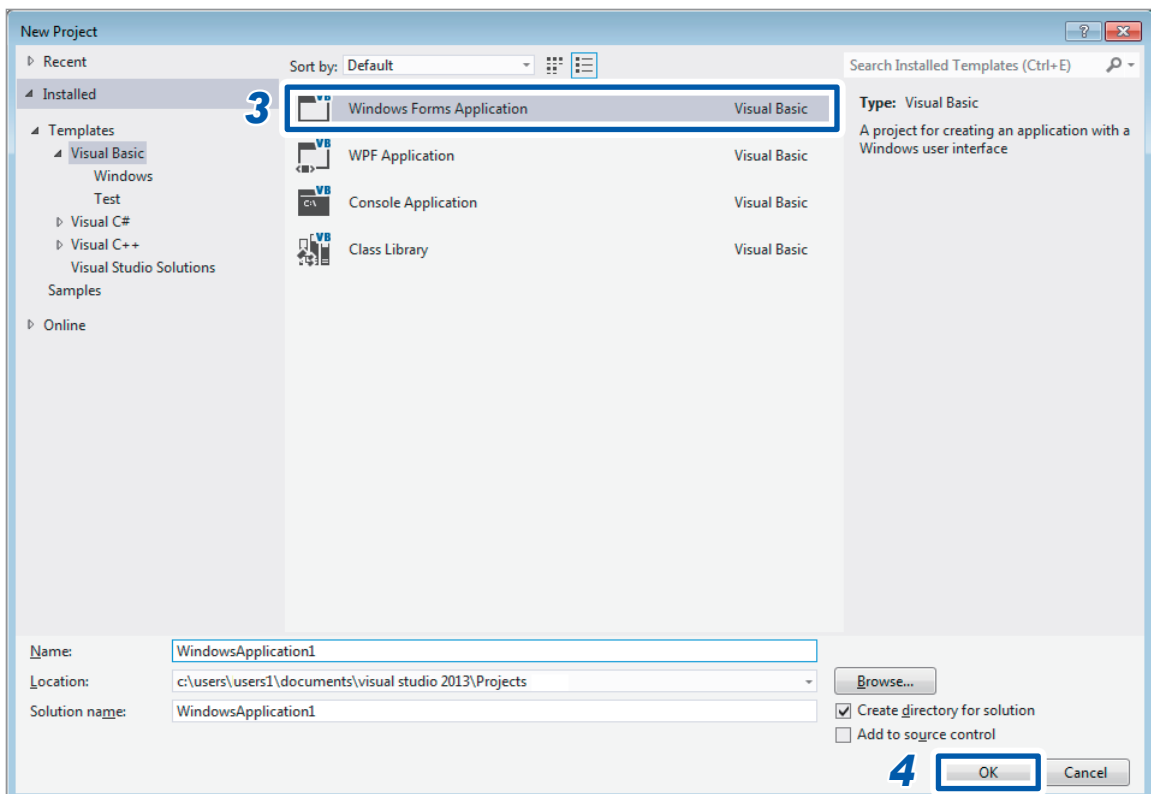

**4** Click [OK].

## (2) Placing a button

1 Click **[Button]** under **[Common Controls]** of **[Toolbox]**.

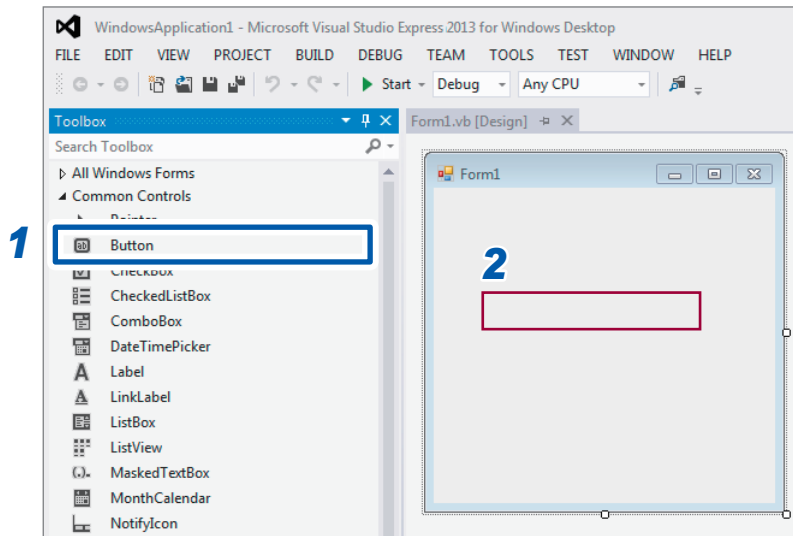

2 Drag and drop the button onto the form layout screen.

3 Change **[Text]** to **[Start Measurement]** under **[Properties]**.

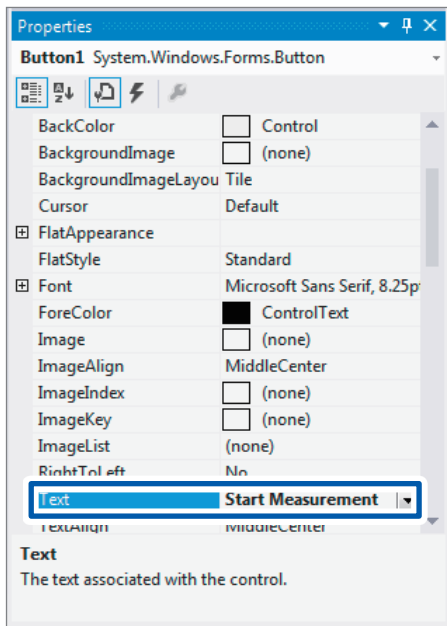

The **[Start Measurement]** button is placed on the form.

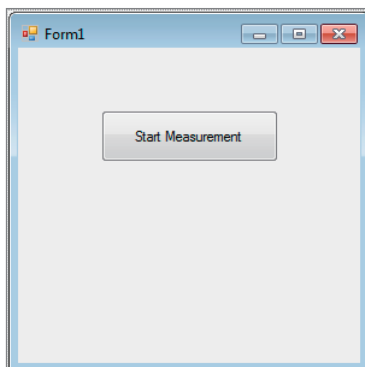

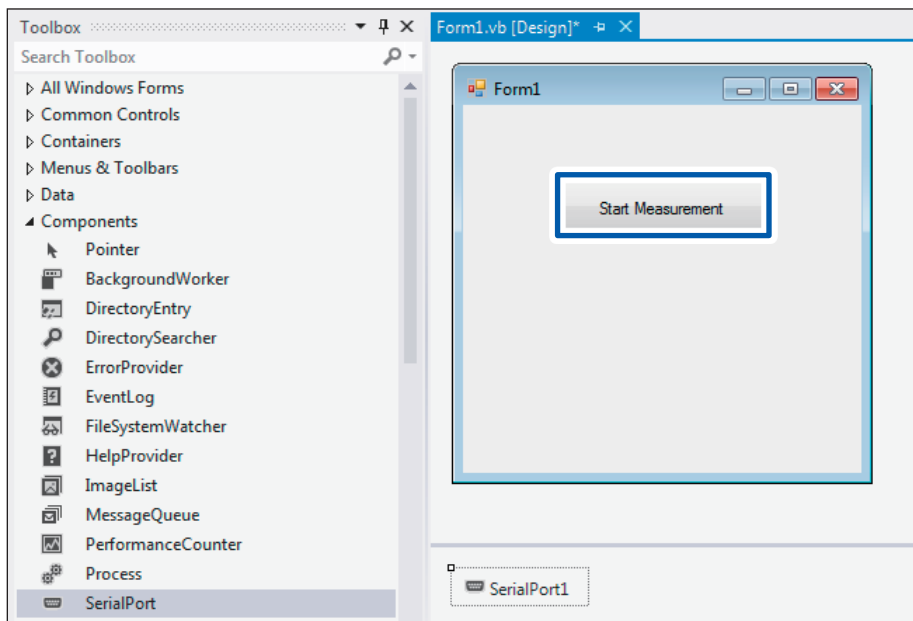
**(3) Describing the code****1 Double-click the placed button.**

The code editor appears.

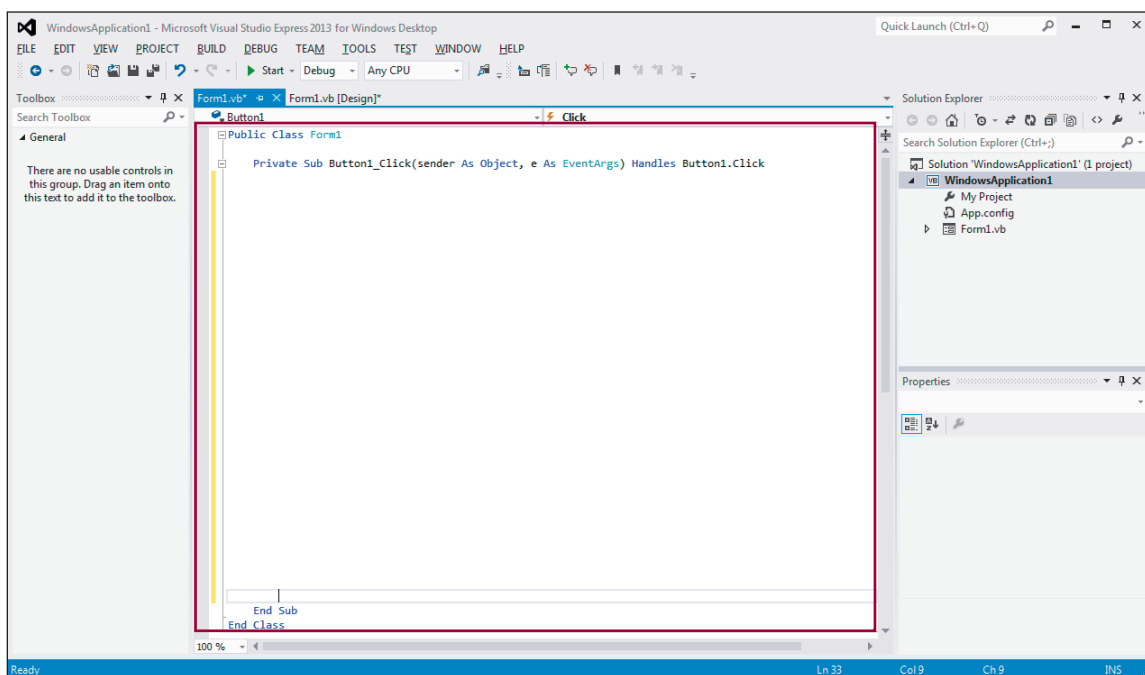
**2 Enter the sample program into the code editor.**

### 3 Select [File] – [Save All].

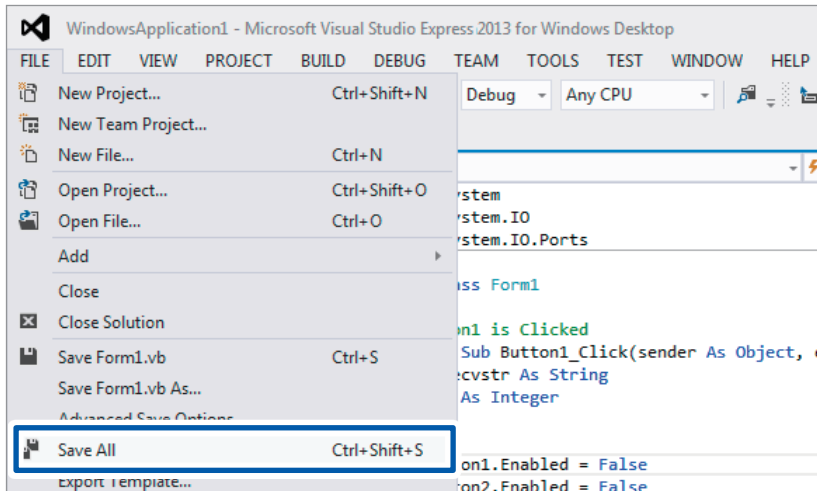

### 4 Check the save location and click [Save as].

## Using the DM7276 to perform scan measurement

Connect the SW1001 and DM7276 to their respective COM ports and perform scan measurement from CH1 to CH22 for **SLOT 1**.

The USB interface can be used to communicate with the device in the same manner as the RS-232C interface. Check the COM number for the USB connection in the device properties and use that number for communications. Communications speed has no meaning in the context of a USB connection.

```
Imports System.IO.Ports

'Scan measurement sample
Public Class Form1
    Private Sub Button1_Click(sender As Object, e As EventArgs) Handles Button1.Click
        Dim sp1 As SerialPort
        Dim sp2 As SerialPort
        Dim writer1 As IO.StreamWriter
        Dim unit_no As Integer
        Dim ch_no As Integer
        Dim ch_str As String
        Dim recv_str As String

        'Connect the SW1001 to COM3.
        sp1 = New System.IO.Ports.SerialPort("COM3", 9600, Parity.None, 8, StopBits.One)
        sp1.NewLine = vbCrLf : sp1.ReadTimeout = 1000

        'Connect the DM7276 to COM4.
        sp2 = New System.IO.Ports.SerialPort("COM4", 9600, Parity.None, 8, StopBits.One)
        sp2.NewLine = vbCrLf : sp2.ReadTimeout = 1000

        sp1.Open()
        sp2.Open()
        sp1.DiscardInBuffer()
        sp2.DiscardInBuffer()

        'Open a file for saving
        writer1 = New IO.StreamWriter(Application.StartupPath + "\data.csv")

        'Configure SLOT1 as a 2-wire connection
        sp1.WriteLine(":SYST:MOD:WIRE:MODE 1,WIRE2")
        sp1.WriteLine("*OPC?")
        sp1.ReadLine()

        For unit_no = 1 To 1
            For ch_no = 1 To 22
                'Create a string to specify the channel.
                ch_str = Format(unit_no, "00") + Format(ch_no, "00")

                'Close the specified channel and wait for the operation to complete
                sp1.WriteLine(":CLOS " + ch_str)
                sp1.WriteLine("*OPC?")
                sp1.ReadLine()

                'Send the one-time measurement command to the DM7276 and receive the measured value.
                sp2.WriteLine(":READ?")
                recv_str = sp2.ReadLine()

                'Write measurement data to a file
                writer1.WriteLine(ch_str + "," + recv_str)
            Next
        Next
    End Sub
End Class
```

## Sample Programs

```
'Open all relays after the scan completes.  
sp1.WriteLine(":OPEN")  
  
writer1.Close()  
sp1.Close()  
sp2.Close()  
sp1.Dispose()  
sp2.Dispose()  
End Sub  
End Class
```

**Measure the internal resistance using the BT3562 and measure the OCV using the DM7276.**

Connect the SW1001 and BT3562, DM7276 to their respective COM ports and perform scan measurement of internal resistance and OCV from CH1 to CH11 for **SLOT 1**.

```
Imports System.IO.Ports

'Scan measurement sample
Public Class Form1
    Private Sub Button1_Click(sender As Object, e As EventArgs) Handles Button1.Click
        Dim sp1 As SerialPort
        Dim sp2 As SerialPort
        Dim sp3 As SerialPort
        Dim writer1 As IO.StreamWriter

        Dim unit_no As Integer
        Dim ch_no As Integer
        Dim ch_str As String
        Dim ir_str(50) As String
        Dim ocv_str(50) As String
        Dim i As Integer

        'Connect the SW1001 to COM3.
        sp1 = New System.IO.Ports.SerialPort("COM3", 9600, Parity.None, 8, StopBits.One)
        sp1.NewLine = vbCrLf : sp1.ReadTimeout = 1000

        'Connect the BT3562 to COM4.
        sp2 = New System.IO.Ports.SerialPort("COM4", 9600, Parity.None, 8, StopBits.One)
        sp2.NewLine = vbCrLf : sp2.ReadTimeout = 1000

        'Connect the DM7276 to COM5.
        sp3 = New System.IO.Ports.SerialPort("COM5", 9600, Parity.None, 8, StopBits.One)
        sp3.NewLine = vbCrLf : sp2.ReadTimeout = 1000

        sp1.Open()
        sp2.Open()
        sp3.Open()
        sp1.DiscardInBuffer()
        sp2.DiscardInBuffer()
        sp3.DiscardInBuffer()

        'Open a file for saving
        writer1 = New IO.StreamWriter(Application.StartupPath + "\data.csv")

        'Configure SLOT1 as a 4-wire connection
        sp1.WriteLine(":SYST:MOD:WIRE:MODE 1,WIRE4")
        sp1.WriteLine("*OPC?")
        sp1.ReadLine()

        'Turn off the continuous measurement of BT3562.
        sp2.WriteLine(":INIT:CONT OFF")

        i = 0
        For unit_no = 1 To 1
            For ch_no = 1 To 11
                'Create a string to specify the channel.
                ch_str = Format(unit_no, "00") + Format(ch_no, "00")

                'Close the specified channel and wait for the operation to complete
                sp1.WriteLine(":CLOS " + ch_str)
                sp1.WriteLine("*OPC?")
                sp1.ReadLine()

                'Send the one-time measurement command to the BT3562 and receive the measured value.
                sp2.WriteLine(":READ?")
                ir_str(i) = sp2.ReadLine()
                i = i + 1
            Next
        Next
    End Class
Next
```



```

'Configure SLOT1 as a 2-wire connection
sp1.WriteLine(":SYST:MOD:WIRE:MODE 1,WIRE2")
sp1.WriteLine("*OPC?")
sp1.ReadLine()

i = 0
For unit_no = 1 To 1
  For ch_no = 12 To 22    'The 2-wire CH12 corresponds to the 4-wire CH1 sense.
    'Create a string to specify the channel.
    ch_str = Format(unit_no, "00") + Format(ch_no, "00")

    'Close the specified channel and wait for the operation to complete
    sp1.WriteLine(":CLOS " + ch_str)
    sp1.WriteLine("*OPC?")
    sp1.ReadLine()

    'Send the one-time measurement command to the DM7276 and receive the measured value.
    sp3.WriteLine(":READ?")
    ocv_str(i) = sp3.ReadLine()
    i = i + 1
  Next
Next

'Open all relays after the scan completes.
sp1.WriteLine(":OPEN")

'Write the CH1 to CH11 measurement data of SLOT 1 to a file
i = 0
For unit_no = 1 To 1
  For ch_no = 1 To 11
    ch_str = Format(unit_no, "00") + Format(ch_no, "00")
    writer1.WriteLine(ch_str + "," + ir_str(i) + "," + ocv_str(i))
    i = i + 1
  Next
Next

writer1.Close()
sp1.Close()
sp2.Close()
sp3.Close()
sp1.Dispose()
sp2.Dispose()
sp3.Dispose()
End Sub
End Class

```

## 9.1 SW1001, SW1002 General Specification

|   |   |  |
|---|---|--|
| <b>Operating environment</b>              | Indoor, pollution level 2, altitude up to 2000 m (6562 ft.)   |  |
| <b>Operating temperature and humidity</b> | Temperature   | 0°C to 40°C (32°F to 104°F)  |
|   | Humidity  | 80% RH or less (no condensation)   |
| <b>Storage temperature and humidity</b>   | Temperature   | -10°C to 50°C (14°F to 122°F)  |
|   | Humidity  | Less than 40°C (104°F), 80% RH or less (no condensation)<br>40°C (104°F) or higher and less than 45°C (113°F), 60% RH or less (no condensation)<br>45°C to 50°C (113°F to 122°F), 50% RH or less (no condensation) |
| <b>Standards</b>                          | Safety  | EN61010  |
|   | EMC   | EN61326 Class A  |
| <b>Power supply</b>                       | Commercial power supply   |  |
|   | Rated supply voltage:   | 100 V to 240 V AC<br>(Voltage fluctuations of ±10% from the rated supply voltage are taken into account.)  |
|   | Rated supply frequency:   | 50 Hz/60 Hz  |
|   | Anticipated transient overvoltage:  | 2500 V   |
|   | Maximum rated power:  | 30 VA  |
| <b>Display</b>                            | Power LED, error LED, and remote LED  |  |
| <b>Interface</b>                          | USB, LAN, RS-232C (2 ports), EXT. I/O   |  |
| <b>Dimensions</b>                         | SW1001: Approx. 215W × 132H × 420D mm (8.46"W × 5.20"H × 16.54"D) (excluding protrusion)<br>SW1002: Approx. 430W × 132H × 420D mm (16.93"W × 5.20"H × 16.54"D) (excluding protrusion) |  |
| <b>Mass (No module attached)</b>          | SW1001: Approx. 3.7 kg (130.5 oz.)<br>SW1002: Approx. 6.0 kg (211.6 oz.)  |  |
| <b>Warranty period</b>                    | 3 years<br>Connector, cable, etc.: Not covered by the warranty  |  |
| <b>Accessories</b>                        | See: "Main unit and accessories" (p.2)  |  |
| <b>Options</b>                            | See: "Options" (p.2)  |  |

## 9.2 SW1001, SW1002 Input Specifications/Output Specifications/Measurement Specificatio

### Basic specification

|  |   |  |
|--|---|--|
| <b>Number of slots</b>                       | 3 slots (SW1001), 12 slots (SW1002)   |  |
| <b>Analog bus</b>                            | Number of systems   | 2-wire 4-system (automatic selection based on the module and connection method)  |
|  | Terminal  | BNC receptacle × 4 (4-terminal pair)<br>Banana terminal receptacle × 4 (4-wire)<br>Banana terminal receptacle × 2 (2-wire) |
| <b>Maximum input voltage</b>                 | 60 V DC, 30 V AC rms, 42.4 V peak   |  |
| <b>Maximum rated voltage to earth</b>        | 60 V DC<br>(Anticipated transient overvoltage: 60 V)                        |  |
| <b>Compatible module</b>                     | Model SW9001 Multiplexer Module<br>Model SW9002 Multiplexer Module          |  |
| <b>Number of instruments to be connected</b> | Maximum 2<br>One 2-wire + one 4-wire or<br>one 2-wire + one 4-terminal pair |  |

## 9.3 SW1001, SW1002 Functional Specification

| <b>Channel switching</b>   | The specified slot and channel is connected to the analog bus based on the communication command.   |   |                        |  |               |   |                                |        |   |   |   |                 |            |        |  |   |
|--|---|---|------------------------|--|---------------|---|--------------------------------|--------|---|---|---|-----------------|------------|--------|--|---|
| <b>Connection method</b>   | 2-wire  | Connect to <b>TERMINAL 1</b>  |                        |  |               |   |                                |        |   |   |   |                 |            |        |  |   |
|  | 4-wire  | Connect to <b>TERMINAL 2</b>  |                        |  |               |   |                                |        |   |   |   |                 |            |        |  |   |
|  | 4-terminal pair   | Connect to <b>TERMINAL 3</b>  |                        |  |               |   |                                |        |   |   |   |                 |            |        |  |   |
|  | Connect to <b>TERMINAL 2</b> and <b>TERMINAL 3</b> in parallel inside.  |   |                        |  |               |   |                                |        |   |   |   |                 |            |        |  |   |
|  | Default setting   | SW9001: 2-wire<br>SW9002: 4-terminal pair   |                        |  |               |   |                                |        |   |   |   |                 |            |        |  |   |
| <b>Channel delay</b>   | The delay time allowed to elapse from channel relay close operation to outputting of the EXT. I/O CLOSE signal can be set.  |   |                        |  |               |   |                                |        |   |   |   |                 |            |        |  |   |
|  | Delay time  | 0.000 s to 9.999 s  |                        |  |               |   |                                |        |   |   |   |                 |            |        |  |   |
|  | Default setting   | Delay time: 0.000 s   |                        |  |               |   |                                |        |   |   |   |                 |            |        |  |   |
| <b>Shield switching</b>  | The shield wire connection point can be set for each slot. However, it is reconfigured to the default with each cycle, according to the connection method when the connection method is changed.  |   |                        |  |               |   |                                |        |   |   |   |                 |            |        |  |   |
|  | <table border="1"> <thead> <tr> <th>Connection destination</th> <th>Default according to the connection method</th> </tr> </thead> <tbody> <tr> <td>Not connected</td> <td>–</td> </tr> <tr> <td><b>TERMINAL 1</b> LOW terminal</td> <td>2-wire</td> </tr> <tr> <td><b>TERMINAL 2</b> source LOW terminal (only for model SW9001)</td> <td>–</td> </tr> <tr> <td><b>TERMINAL 3</b> sense shield terminal</td> <td>4-terminal pair</td> </tr> <tr> <td><b>GND</b></td> <td>4-wire</td> </tr> <tr> <td><b>TERMINAL 1</b> LOW terminal + <b>TERMINAL 3</b> sense shield terminal (only for model SW9001)</td> <td>–</td> </tr> </tbody> </table> |   | Connection destination | Default according to the connection method | Not connected | – | <b>TERMINAL 1</b> LOW terminal | 2-wire | <b>TERMINAL 2</b> source LOW terminal (only for model SW9001) | – | <b>TERMINAL 3</b> sense shield terminal | 4-terminal pair | <b>GND</b> | 4-wire | <b>TERMINAL 1</b> LOW terminal + <b>TERMINAL 3</b> sense shield terminal (only for model SW9001) | – |
| Connection destination   | Default according to the connection method  |   |                        |  |               |   |                                |        |   |   |   |                 |            |        |  |   |
| Not connected  | –   |   |                        |  |               |   |                                |        |   |   |   |                 |            |        |  |   |
| <b>TERMINAL 1</b> LOW terminal   | 2-wire  |   |                        |  |               |   |                                |        |   |   |   |                 |            |        |  |   |
| <b>TERMINAL 2</b> source LOW terminal (only for model SW9001)                                    | –   |   |                        |  |               |   |                                |        |   |   |   |                 |            |        |  |   |
| <b>TERMINAL 3</b> sense shield terminal  | 4-terminal pair   |   |                        |  |               |   |                                |        |   |   |   |                 |            |        |  |   |
| <b>GND</b>   | 4-wire  |   |                        |  |               |   |                                |        |   |   |   |                 |            |        |  |   |
| <b>TERMINAL 1</b> LOW terminal + <b>TERMINAL 3</b> sense shield terminal (only for model SW9001) | –   |   |                        |  |               |   |                                |        |   |   |   |                 |            |        |  |   |
| <b>Scan function</b>   | Operation   | Switch the channel according to the created scan list. Scan operation is triggered by the EXT. I/O SCAN signal or *TRG command input.   |                        |  |               |   |                                |        |   |   |   |                 |            |        |  |   |
|  | Scan operation Trigger source   | STEP Switches channels in the order specified by the scan list at each signal input. EXT. I/O can be used to synchronize channel switching and trigger measurement with one measuring instrument.   |                        |  |               |   |                                |        |   |   |   |                 |            |        |  |   |
|  | Scan list   | Registers scan channels. Maximum number of steps: 1000  |                        |  |               |   |                                |        |   |   |   |                 |            |        |  |   |
|  | Default setting   | Scan operation trigger source: STEP<br>Scan list: none  |                        |  |               |   |                                |        |   |   |   |                 |            |        |  |   |
|  | <b>Communication command forward</b>  | Communication data can be forwarded (sent/received) between the host (PC, PLC) and the instrument connected to the <b>INSTRUMENT RS-232C</b> connector of the device. (Communications with the instrument can be performed using the communication port.) |                        |  |               |   |                                |        |   |   |   |                 |            |        |  |   |
| <b>Setting backup</b>  | Backs up communication settings and scan lists in the non-volatile memory.  |   |                        |  |               |   |                                |        |   |   |   |                 |            |        |  |   |

---

|   |   |  |
|---|---|--|
| <b>Communication setting change-over function</b> | Changes to the “Fixed setting mode/User setting mode” in the communication settings when the slide switch is toggled. |  |
|   | Fixed setting mode<br>( <b>DFLT</b> )   | Communications can be performed via all LAN, USB, and RS-232C interfaces.<br>The LAN interface is set to the fixed setting mode<br>The USB interface and RS-232C interface are set to the default setting. |
|   | User setting mode<br>( <b>USER</b> )  | Sets the communications interface using a command and performs communications according to the settings.   |

---

## 9.4 SW1001, SW1002 Interface Specification

### LAN

|                                  |  |                |
|----------------------------------|--|----------------|
| <b>Applicable standard</b>       | IEEE802.3  |                |
| <b>Transmission method</b>       | 10BASE-T/100BASE-TX automatic recognition<br>Full duplex                                 |                |
| <b>Protocol</b>                  | TCP/IP   |                |
| <b>Connector</b>                 | RJ-45  |                |
| <b>Communication description</b> | Setting and measured value acquisition by using communications commands                  |                |
| <b>Settings</b>                  | IP address, subnet mask, default gateway<br>Communication command port number: 1 to 9999 |                |
| <b>Default setting</b>           | IP address:  | 192.168.0.254  |
|                                  | Subnet mask:   | 255.255.255.0  |
|                                  | Default gateway:   | 0.0.0.0 (None) |
|                                  | Communication command port number:   | 23             |
| <b>Fixed setting mode</b>        | IP address:  | 192.168.0.254  |
|                                  | Subnet mask:   | 255.255.255.0  |
|                                  | Default gateway:   | 0.0.0.0 (None) |
|                                  | Communication command port number:   | 23             |
| <b>Delimiter</b>                 | Sending CR+LF, receiving CR or CR+LF   |                |

### USB

|                                 |                                      |
|---------------------------------|--------------------------------------|
| <b>Electrical specification</b> | USB2.0(Full-Speed)                   |
| <b>Connector</b>                | Series B receptacle                  |
| <b>Class</b>                    | CDC class (USB COM)                  |
| <b>Delimiter</b>                | Sending CR+LF, receiving CR or CR+LF |

### RS-232C

|                            |   |
|----------------------------|---|
| <b>Number of ports</b>     | 2 (host side, instrument side)                |
| <b>Connector</b>           | D-sub 9-pin, male, fixing stud screw #4-40 UN |
| <b>Transmission method</b> | Start-stop system, full duplex                |
| <b>Transmission speed</b>  | 9600 bps/19200 bps/38400 bps                  |
| <b>Data bit length</b>     | 8   |
| <b>Stop bit:</b>           | 1   |
| <b>Parity check</b>        | None  |
| <b>Delimiter</b>           | Sending CR+LF, receiving CR or CR+LF          |

|                                  |   |
|----------------------------------|---|
| <b>Flow control</b>              | None  |
| <b>Protocol</b>                  | Non-procedure   |
| <b>Communication description</b> | Setting and measured value acquisition by using communications commands |
| <b>Default setting</b>           | Transmission speed: 9600 bps  |

## EXT. I/O

|                                    |  |   |
|------------------------------------|--|---|
| <b>Connector</b>                   | D-sub 9-pin, female, fixing stud screw #4-40 UN  |   |
| <b>Input</b>                       |  |   |
| <b>Electrical specification</b>    | Insulation   | Photocoupler isolated non-voltage contact input (Compatible with sinking/sourcing current output) |
|                                    | Input ON   | Residual voltage: 1 V or less<br>Input ON current: 4 mA (reference value)                         |
|                                    | Input OFF  | OPEN (interrupting current 100 $\mu$ A or less)   |
|                                    | Response time  | ON edge: Maximum 0.1 ms,<br>OFF edge: Maximum 1.0 ms  |
| <b>Input signal</b>                | SCAN, SCAN_RESET   |   |
| <b>Output</b>                      |  |   |
| <b>Electrical specification</b>    | Insulation   | Photocoupler isolated open drain output (non-polar)   |
|                                    | Maximum load voltage   | 30 V DC   |
|                                    | Residual voltage   | 1 V or less (load current 50 mA),<br>0.5 V or less (load current 10 mA)                           |
|                                    | Maximum output current   | 50 mA/channel   |
| <b>Output signal</b>               | CLOSE  |   |
| <b>Power supply output</b>         |  |   |
| <b>Output voltage</b>              | Sinking output compatible  | +4.2 V to +5.8 V  |
|                                    | Sourcing output compatible   | -4.2 V to -5.8 V  |
| <b>Maximum output current</b>      | 100 mA   |   |
| <b>External power supply input</b> | None   |   |
| <b>Insulation</b>                  | Floating from the protective grounded potential and the measurement circuit<br>Voltage to ground: 50 V DC, 30 V AC rms, 42.4 V AC peak or less |   |

# 10 Maintenance and Service

## 10.1 Troubleshooting

If damage is suspected, check “Before sending the device for repair” before contacting your authorized Hioki distributor or reseller.

### Before sending the device for repair

| Symptom                         | Check item or cause  | Solution   | Reference                    |
|---------------------------------|--|--|------------------------------|
| No input to the instrument.     | The power is not turned on.  | Check the power cord and turn on the power switch.   | p.23                         |
|                                 | The measurement cable for the measuring object is disconnected.                    | Connect the measurement cable to each module. Check that the measurement cable is connected to the measuring object.   | p.18                         |
|                                 | The connection cable for the instrument is disconnected.                           | Check the connection cable between the device and instrument.  | p.19                         |
|                                 | The module connection method is set incorrectly.                                   | Check the terminal to be connected to the instrument and select the correct connection method.   | p.19<br>p.28                 |
|                                 | Communications or control cannot be performed (the <b>REMOTE</b> lamp is not lit). | Check that the communication cable is connected. Check the LAN settings. Disconnect the USB cable and connect it to the PC again. Use the RS-232C cross cable. | p.22<br>p.61<br>p.65<br>p.66 |
| The channel cannot be switched. | The module connection method is set incorrectly.                                   | Check the terminal to be connected to the instrument and select the correct connection method.   | p.28                         |
| Scanning cannot be performed.   | The scan list is not specified   | Specify and set the scan list.   | p.40                         |
|                                 | The EXT. I/O connection is incorrect.  | Check the EXT. I/O connection.   | p.51                         |



## Error display and troubleshooting

If the **ERROR** lamp is lit at the time of startup, it is necessary to repair the device. Contact your authorized Hioki distributor or reseller.

| Error LED display             | Cause                   | Solution   | Reference |
|-------------------------------|-------------------------|--|-----------|
| The <b>ERROR</b> lamp is lit. | Command error           | Check the send command character string.<br>Check that the parameters are correct.   | p.71      |
|                               | Execution error         | Some commands cannot be used during scan operation. Check that those commands are not used.<br>Some commands cannot be used under specific conditions. | p.80      |
|                               | Startup self-test error | When an error occurs during self-test, the <b>ERROR</b> lamp lights up and the device cannot be controlled.<br>Repair is necessary.                    | p.23      |

## 10.2 List of Device Error Numbers

This section provides a list of device error numbers.

You can acquire the number of any error that occurs as well as a description of the error using the `:SYSTem:ERRor?` query.

See: "Query and clear error information" (p. 100)

| Error No. | Error description          | Details   | Solution   | Reference |
|-----------|----------------------------|---|--|-----------|
| -100      | Command error              | Illegal command string  | Check whether there is no error in the command string.   | p.71      |
| -200      | Execution error            | Unable to execute command with the specified condition          | It may not be possible to execute the command in question under the present conditions.                                      | p.80      |
| -220      | Parameter error            | Out-of-range or illegal parameter                               | Check the command parameter range or string.   | p.103     |
| -222      | Bad Slot/Ch                | Illegal slot or channel specificatio                            | Check the specification method and parameter string.   | p.98      |
| -313      | Backup lost                | Corrupt device hardware information                             | Repair is necessary.   | -         |
| -315      | Setting backup lost        | Corrupt settings backup data                                    |  |           |
| -330      | Self-test failed           | Error during self-test  |  |           |
| -360      | Communication error        | Communications error  | Check the communications settings (forward speed, etc.). Check whether the communications lines are being affected by noise. | p.68      |
| -361      | Rs232c parity error        | RS-232C parity error  |  |           |
| -362      | Rs232c framing error       | RS-232C framing error   |  |           |
| -363      | Rs232c overrun             | RS-232C overrun error   |  |           |
| -365      | Time out error             | Timeout   |  |           |
| -370      | Module backup failed       | Corrupt module information                                      | Repair is necessary.   | -         |
| -371      | Comm transfer Timeout      | Communications forwarding function timeout                      | Check the communications settings on the connected instrument. Check the command being sent for errors.                      | p.69      |
| -372      | Comm transfer overrun      | Communications forwarding function receive buffer full          |  |           |
| -373      | Comm Transfer RS232C error | Communications forwarding function RS-232C communications error |  |           |
| -400      | Query error                | Full send buffer when sending a query                           | Be sure to receive the response when you send a query.   | p.76      |

## 10.3 Repair and Inspection

### Replaceable parts and operating lifetimes

The characteristics of some of the parts used in the product may deteriorate with extended use. To ensure the product can be used over the long term, it is recommended to replace these parts on a periodic basis.

When replacing parts, please contact your authorized Hioki distributor or reseller.

The operating lifetime of the parts varies depending on the operating environment and frequency of use. Parts are not guaranteed to operate throughout the recommended replacement cycle.

| Part name              | Recommended replacement cycle   | Remarks/Conditions   |
|------------------------|---|--|
| Electrolytic capacitor | Approx. 10 years  | The board on which this part is installed needs to be replaced.    |
| Relay                  | 50 million cycles, no load  | Since the relay is consumable, a new module needs to be purchased. |
|                        | 10 million cycles, 30 V capacitive load<br>(Peak 500 mA, pulse width 1 $\mu$ s) |  |

The module relay cannot be repaired or replaced. Please purchase a new module.

Thoroughly read "Before installing the module" (p.5) beforehand.

## 11.1 SW9001 Multiplexer Module (2-wire/4-wire)

### Features

The SW9001 is a multiplexer module that can be attached to the SW1001 or SW1002 Switch Mainframe.

- 2-wire 22-channel or 4-wire 11-channel multiplexer
- The module reduces electromagnetic induction (eddy current) in AC impedance measurement and minimizes the influence on measured values by reducing magnetic flux leakage due to measurement current and separating the source wire from the sense wire.
- It can be connected up to 2 instruments by switching the analog bus.

### Specification

#### General Specification

|   |   |  |
|---|---|--|
| <b>Operating environment</b>              | Indoor, pollution degree 2, altitude up to 2000 m (6562 ft.)                          |  |
| <b>Operating temperature and humidity</b> | Temperature   | 0°C to 40°C (32°F to 104°F)  |
|   | Humidity  | 80% RH or less (no condensation)   |
| <b>Storage temperature and humidity</b>   | Temperature   | -10°C to 50°C (14°F to 122°F)  |
|   | Humidity  | Less than 40°C (104°F), 80% RH or less (no condensation)<br>40°C (104°F) or higher and less than 45°C (113°F), 60% RH or less (no condensation)<br>45°C to 50°C (113°F to 122°F), 50% RH or less (no condensation) |
| <b>Standards</b>                          | Safety  | EN61010  |
|   | EMC   | EN61326 Class A  |
| <b>Dimensions</b>                         | Approx. 25.5W × 110H × 257D mm (1.00"W × 4.33"H × 10.12"D) (excluding the projection) |  |
| <b>Mass</b>                               | Approx. 210 g (7.4 oz.)   |  |
| <b>Product warranty period</b>            | 3 years<br>Relays, fuses, and connector: Not covered by the warranty                  |  |
| <b>Accessory</b>                          | Instruction Manual  |  |

## Basic specification

|  |   |   |
|--|---|---|
| <b>Number of channels</b>  | 22 channels (2-wire)/11 channels (4-wire)   |   |
| <b>Contact system</b>  | Armature relay  |   |
| <b>Connection method</b>   | 2-wire/4-wire   |   |
| <b>Opening/closing time</b>  | 5 ms (open) /5 ms (close)<br>Except for the control time and contact bounce time  |   |
| <b>Channel switching operation</b>                                   | Break before make   |   |
| <b>Channel switching time</b>  | 11 ms (excluding the measurement time)  |   |
| <b>Contact rating</b>  | Maximum allowable voltage   | Between HIGH and LOW, 60 V DC, 30 V AC rms, 42.4 V peak |
|  | Maximum allowable current   | Between HIGH and LOW, 1 A DC, 1 A AC rms                |
|  | Maximum allowable power   | Between HIGH and LOW, 30 W (resistance load)            |
| <b>Maximum rated voltage to earth</b>                                | 60 V DC<br>(Anticipated transient overvoltage: 60 V)  |   |
| <b>Offset voltage*<sup>1</sup></b>                                   | Less than 5 $\mu$ V (for <b>TERMINAL 1</b> and <b>TERMINAL 2</b> sense terminals)   |   |
| <b>Initial circuit resistance (Cycle value between HIGH and LOW)</b> | Less than 1.5 $\Omega$ (when SW1001 or SW1002 <b>TERMINAL 1</b> is used)  |   |
|  | Less than 0.7 $\Omega$ (when SW1001 or SW1002 <b>TERMINAL 2, TERMINAL 3</b> is used)  |   |
| <b>Insulation resistance (at 60 V DC)</b>                            | Channel between HIGH and LOW  | 1 G $\Omega$ or more                                    |
|  | Between channels  | 1 G $\Omega$ or more                                    |
|  | Between channel and ground  | 1 G $\Omega$ or more                                    |
| <b>Capacitance*<sup>2</sup></b>                                      | Channel between HIGH and LOW  | Less than 3000 pF                                       |
|  | Between channels  | Less than 100 pF  |
|  | Between channel and ground  | Less than 1000 pF                                       |
| <b>Contact lifetime (reference value)</b>                            | No load   | 50 million cycles                                       |
|  | 30 V capacitive load<br>(1.2 $\mu$ F + 60 $\Omega$ ,<br>Peak 500 mA)  | 10 million cycles                                       |
| <b>Short protection fuse (Cannot be replaced by customers)</b>       | For every channel<br>Rated current 1.6 A DC, fusing current 4.0 A DC  |   |
| <b>Shield switching</b>  | The shield wire connection point can be selected from the following.<br><b>TERMINAL 1</b> LOW, <b>TERMINAL 2</b> source LOW, <b>TERMINAL 3</b> sense shield,<br><b>TERMINAL 1</b> LOW + <b>TERMINAL 3</b> sense shield, <b>GND</b> , or not connected |   |
| <b>Contact opening/closing frequency recording</b>                   | Recorded for every relay<br>Maximum recording count 1 billion times<br>Recorded in the internal non-volatile memory   |   |
| <b>Measurement connector</b>   | D-sub 50-pin, male, screw #4-40 UNC   |   |

\*1: Offset voltage is the value 1 minute after the channel is closed. The ambient temperature is supposed to be completely stabilized and the device is fully adjusted to the ambient temperature.

\*2: When twelve units of the SW9001 are installed in the SW1002, measurement frequency is 100 kHz.

## Measurement influenc

### (1) Conditions

|                                 |   |
|---------------------------------|---|
| <b>Warm-up time</b>             | None  |
| <b>Temperature and humidity</b> | 23°C±5°C (73°F±9°F), 80% RH or less   |
| <b>Measurement conditions</b>   | Measurement cable length 0 m (Connect the measuring object to the SW9001's connector.)<br>Use the specified connection cable between the switch mainframe and the target measuring instrument.<br>Based on the conditions separately defined for each target measuring instrument<br>Based on the guaranteed accuracy conditions for use in conjunction with an instrument. |

### (2) Combined measurement accuracy

The combined measurement accuracy for an instrument and the switch (main frame and module) can be calculated using the following formula:

Combined measurement accuracy = Instrument accuracy + combination measurement influenc

### (3) Combination measurement influence

#### BT3562 and BT3563 (connected using L2108)

| Range            | Measurement influenc   | Conditions, remarks  |
|------------------|------------------------|--|
| R 3 mΩ           | ±0.1% f.s.             | –  |
| R 30 mΩ to 300 Ω | ±0.03% f.s.            | –  |
| R 3000 Ω         | ±3.0% rdg. ±0.03% f.s. | Measurement errors cannot be detected.   |
| All V Ranges     | ±5 μV*                 | After the ambient operating temperature is stabilized.<br>Within 1 minute after the contact is closed. |

#### 3561 (connected using L2108)

| Range        | Measurement influenc | Conditions, remarks  |
|--------------|----------------------|--|
| All R ranges | ±0.03% f.s.          | –  |
| All V ranges | ±5 μV*               | After the ambient operating temperature is stabilized.<br>Within 1 minute after the contact is closed. |

#### DM7275 and DM7276 (connected using L4930)

| Range        | Measurement influenc | Conditions, remarks  |
|--------------|----------------------|--|
| All V ranges | ±7 μV*               | After the ambient operating temperature is stabilized.<br>Within 1 minute after the contact is closed. |

\*: Voltage measurement influence includes the offset voltage indicated in the basic specifications

## Switching wiring diagram

SW9001 Multiplexer Module 2-Wire 22CH/4-Wire 11CH

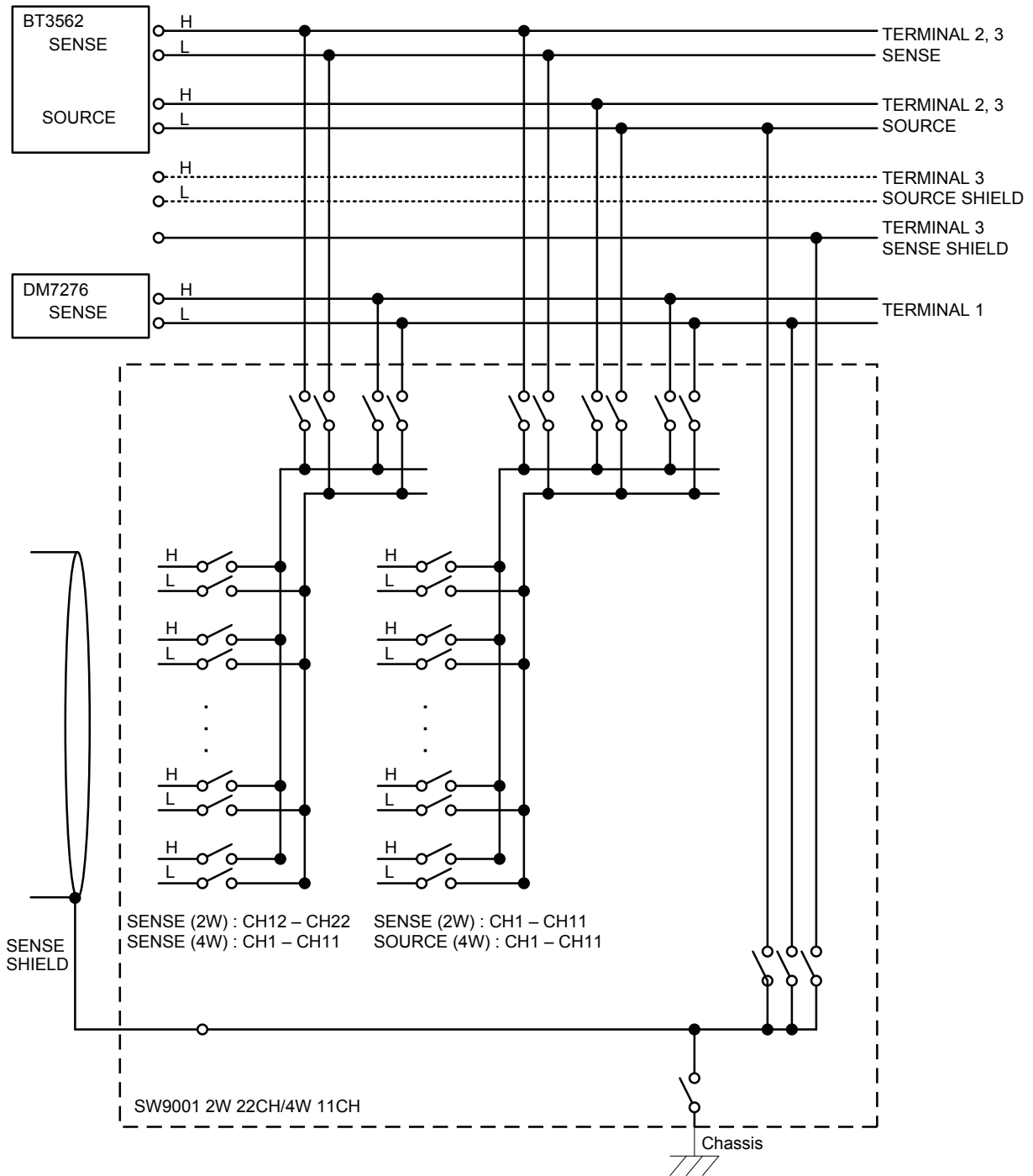

## Connector wiring diagram

### SW9001 connector signal list

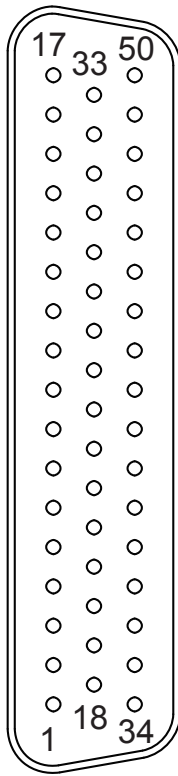

| Pin No. | Signal |   | Pin No. | Signal |   | Pin No. | Signal |   |
|---------|--------|---|---------|--------|---|---------|--------|---|
| 17      | Shield |   | 33      | CH11   | H | 50      | CH11   | L |
| 16      | CH10   | H | 32      | CH9    | L | 49      | CH10   | L |
| 15      | CH9    | H | 31      | CH8    | H | 48      | CH8    | L |
| 14      | CH7    | H | 30      | CH6    | L | 47      | CH7    | L |
| 13      | CH6    | H | 29      | CH5    | H | 46      | CH5    | L |
| 12      | CH4    | H | 28      | CH3    | L | 45      | CH4    | L |
| 11      | CH3    | H | 27      | CH2    | H | 44      | CH2    | L |
| 10      | CH1    | H | 26      | Shield |   | 43      | CH1    | L |
| 9       | Shield |   | 25      | CH22   | H | 42      | CH22   | L |
| 8       | CH21   | H | 24      | CH20   | L | 41      | CH21   | L |
| 7       | CH20   | H | 23      | CH19   | H | 40      | CH19   | L |
| 6       | CH18   | H | 22      | CH17   | L | 39      | CH18   | L |
| 5       | CH17   | H | 21      | CH16   | H | 38      | CH16   | L |
| 4       | CH15   | H | 20      | CH14   | L | 37      | CH15   | L |
| 3       | CH14   | H | 19      | CH13   | H | 36      | CH13   | L |
| 2       | CH12   | H | 18      | Shield |   | 35      | CH12   | L |
| 1       | Shield |   | –       | –      |   | 34      | Shield |   |

For 4-wire, channel n and channel n+11 is a pair of source and sense.

The measurement connector frame of the module is connected to the casing (metal) of the device as well as the protective ground terminal of the power inlet (conductive).



## Acquiring the relay opening/closing frequency

You can acquire the relay opening/closing frequency as stored in the module's non-volatile memory. To acquire the relay opening/closing frequency, use :**SYSTEM:MODULE:COUNT?** (p.88). Relays are identified by number alone (Relay 1 through Relay 31)

### Correspondence of module relays and relay numbers (SW9001)

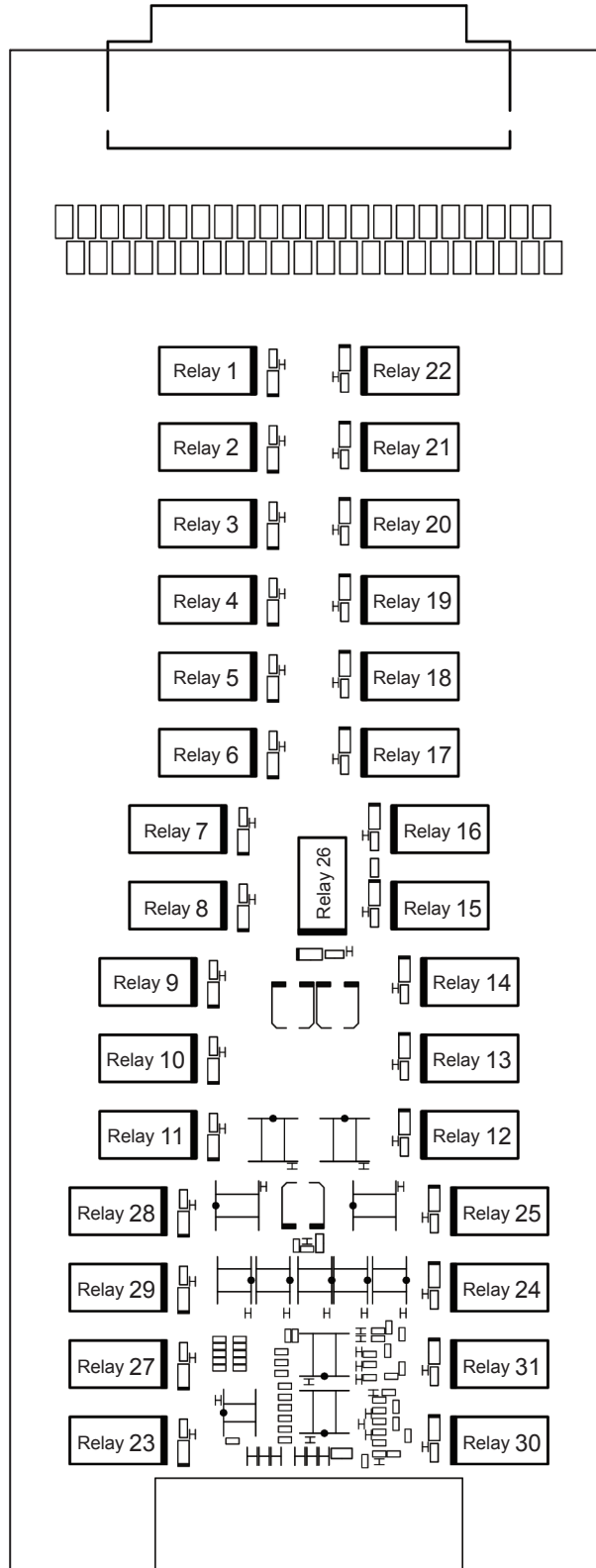

## 11.2 SW9002 Multiplexer Module (4-terminal pair)

### Features

The SW9002 is a multiplexer module that can be attached to the SW1001 or SW1002 Switch Mainframe.

- 4-terminal-pair 6-channel multiplexer
- It can be switched to 2-wire (sense channel only).
- The 4-terminal pair structure reduces electromagnetic induction (eddy current) in AC impedance measurement and minimizes the influence on measured values
- An LCR meter can be used with shield wire connection between sense and source H and L.
- It can be connected up to 2 instruments by switching the analog bus.

### Specification

#### General Specification

|   |   |  |
|---|---|--|
| <b>Operating environment</b>              | Indoor, pollution degree 2, altitude up to 2000 m (6562 ft.)                          |  |
| <b>Operating temperature and humidity</b> | Temperature   | 0°C to 40°C (32°F to 104°F)  |
|   | Humidity  | 80% RH or less (no condensation)   |
| <b>Storage temperature and humidity</b>   | Temperature   | -10°C to 50°C (14°F to 122°F)  |
|   | Humidity  | Less than 40°C (104°F), 80% RH or less (no condensation)<br>40°C (104°F) or higher and less than 45°C (113°F), 60% RH or less (no condensation)<br>45°C to 50°C (113°F to 122°F), 50% RH or less (no condensation) |
| <b>Standards</b>                          | Safety  | EN61010  |
|   | EMC   | EN61326 Class A  |
| <b>Dimensions</b>                         | Approx. 25.5W × 110H × 257D mm (1.00"W × 4.33"H × 10.12"D) (excluding the projection) |  |
| <b>Mass</b>                               | Approx. 196 g (6.9 oz.)   |  |
| <b>Product warranty period</b>            | 3 years<br>Relays, fuses, and connector: Not covered by the warranty                  |  |
| <b>Accessory</b>                          | Instruction Manual  |  |

## Basic specification

|  |  |   |
|--|--|---|
| <b>Number of channels</b>  | 6 channels   |   |
| <b>Contact system</b>  | Armature relay   |   |
| <b>Connection method</b>   | 4-terminal pair/2-wire   |   |
| <b>Opening/closing time</b>  | 5 ms (open) /5 ms (close)<br>Except for the control time and contact bounce time   |   |
| <b>Channel switching operation</b>                                   | Break before make  |   |
| <b>Channel switching time</b>  | 11 ms (excluding the measurement time)   |   |
| <b>Contact rating</b>  | Maximum allowable voltage  | Source: Between HIGH and LOW, 60 V DC, 30 V AC rms, 42.4 V peak<br>Sense: Between HIGH and LOW, 60 V DC, 30 V AC rms, 42.4 V peak |
|  | Maximum allowable current  | Source: Between HIGH and LOW, 2 A DC, 2 A AC rms<br>Sense: Between HIGH and LOW, 1 A DC, 1 A AC rms                               |
|  | Maximum allowable power  | Source: Between HIGH and LOW, 30 W (resistance load)<br>Sense: Between HIGH and LOW, 30 W (resistance load)                       |
| <b>Maximum rated voltage to earth</b>                                | 60 V DC<br>(Anticipated transient overvoltage: 60 V)   |   |
| <b>Offset voltage*<sup>1</sup></b>                                   | Less than 5 $\mu$ V (for <b>TERMINAL 1</b> and <b>TERMINAL 2</b> sense terminals)  |   |
| <b>Initial circuit resistance (Cycle value between HIGH and LOW)</b> | Less than 1.5 $\Omega$ (when SW1001 or SW1002 <b>TERMINAL 1</b> is used)   |   |
|  | Less than 1.0 $\Omega$ (when SW1001 or SW1002 <b>TERMINAL 2, TERMINAL 3</b> is used)   |   |
| <b>Insulation resistance (at 60 V DC)</b>                            | Channel between HIGH and LOW   | 1 G $\Omega$ or more  |
|  | Between channels   | 1 G $\Omega$ or more  |
|  | Between channel and ground   | 1 G $\Omega$ or more  |
| <b>Capacitance*<sup>2</sup></b>                                      | Channel between HIGH and LOW   | Less than 100 pF (when connected to BT4560, IM3590* <sup>3</sup> )<br>Less than 3000 pF (other than the above)                    |
|  | Between channels   | Less than 100 pF  |
|  | Between channel and ground   | Less than 1000 pF   |
| <b>Contact lifetime (reference value)</b>                            | No load  | 50 million cycles   |
| <b>Short protection fuse (Cannot be replaced by customers)</b>       | For every channel<br>Rated current 1.6 A DC, fusing current 4.0 A DC (sense)<br>Rated current 2.5 A DC, fusing current 6.25 A DC (source, return)                  |   |
| <b>Shield switching</b>  | The shield wire connection point can be selected from the following.<br><b>TERMINAL 1</b> sense LOW, <b>TERMINAL 3</b> sense shield, <b>GND</b> , or not connected |   |
| <b>Contact opening/closing frequency recording</b>                   | Recorded for every relay.<br>Maximum recording count 1 billion times<br>Recorded in the internal non-volatile memory.  |   |
| <b>Measurement connector</b>   | D-sub 37-pin, male, screw #4-40 UNC  |   |

\*1: Offset voltage is the value 1 minute after the channel is closed. The ambient temperature is supposed to be completely stabilized and the device is fully adjusted to the ambient temperature.

\*2: When twelve units of the SW9002 are installed in the SW1002, measurement frequency is 100 kHz.

\*3: When connecting the shielding to the **TERMINAL 3** sense shielding. For other connections, less than 3000 pF.

## Measurement influenc

### (1) Conditions

|                          |   |
|--------------------------|---|
| Warm-up time             | None  |
| Temperature and humidity | 23°C±5°C (73°F±9°F), 80% RH or less   |
| Measurement conditions   | Measurement cable length 0 m (Connect the measuring object to the SW9002's connector.)<br>Use the specified connection cable between the switch mainframe and the target measuring instrument.<br>Based on the conditions separately defined for each target measuring instrument<br>Based on the guaranteed accuracy conditions for use in conjunction with an instrument. |

### (2) Combined measurement accuracy

The combined measurement accuracy for an instrument and the switch (main frame and module) can be calculated using the following formula:

Combined measurement accuracy = Instrument accuracy + combination measurement influenc

### (3) Combination measurement influence

#### BT4560 (connected using L2004)

| Range        | Measurement influenc                |                                      | Conditions, remarks  |
|--------------|-------------------------------------|--------------------------------------|--|
|              | Frequency range<br>0.1 Hz to 100 Hz | Frequency range<br>110 Hz to 1050 Hz |  |
| 3 mΩ R       | ±0.05% f.s.                         | ±0.1% f.s.                           | –  |
| 3 mΩ X       | ±0.1% f.s.                          | ±1.0% f.s.                           | –  |
| 10 mΩ R      | ±0.015% f.s.                        | ±0.03% f.s.                          | –  |
| 10 mΩ X      | ±0.03% f.s.                         | ±0.3% f.s.                           | –  |
| 100 mΩ R     | ±0.01% f.s.                         | ±0.01% f.s.                          | –  |
| 100 mΩ X     | ±0.015% f.s.                        | ±0.03% f.s.                          | –  |
| All V ranges | ±5 μV* <sup>1</sup>                 |                                      | After the ambient operating temperature is stabilized.<br>Within 1 minute after the contact is closed. |

#### IM3590\*<sup>2</sup> (connected using L2004)

| Range          | Measurement influenc              | Conditions, remarks  |
|----------------|-----------------------------------|--|
| 100 mΩ to 10 Ω | (IM3590 measurement accuracy) × 1 | DC, 0.001 Hz to 10.000 kHz                                   |
| 100 Ω to 10 kΩ | (IM3590 measurement accuracy) × 3 | DC, 0.001 Hz to 10.000 kHz<br>Upper limit of impedance 10 kΩ |

#### DM7275 and DM7276 (connected using L4930)

| Range        | Measurement influenc | Conditions, remarks  |
|--------------|----------------------|--|
| All V ranges | ±7 μV* <sup>1</sup>  | After the ambient operating temperature is stabilized.<br>Within 1 minute after the contact is closed. |

\*1: Voltage measurement influence includes the offset voltage indicated in the basic specifications

\*2: Combination measurement influence provided for use with the IM3590 are offered as reference values.  
Reference values describe a specific example and do not constitute a guarantee

# Switching wiring diagram

SW9002 Multiplexer Module 4-Terminal Pair 6CH

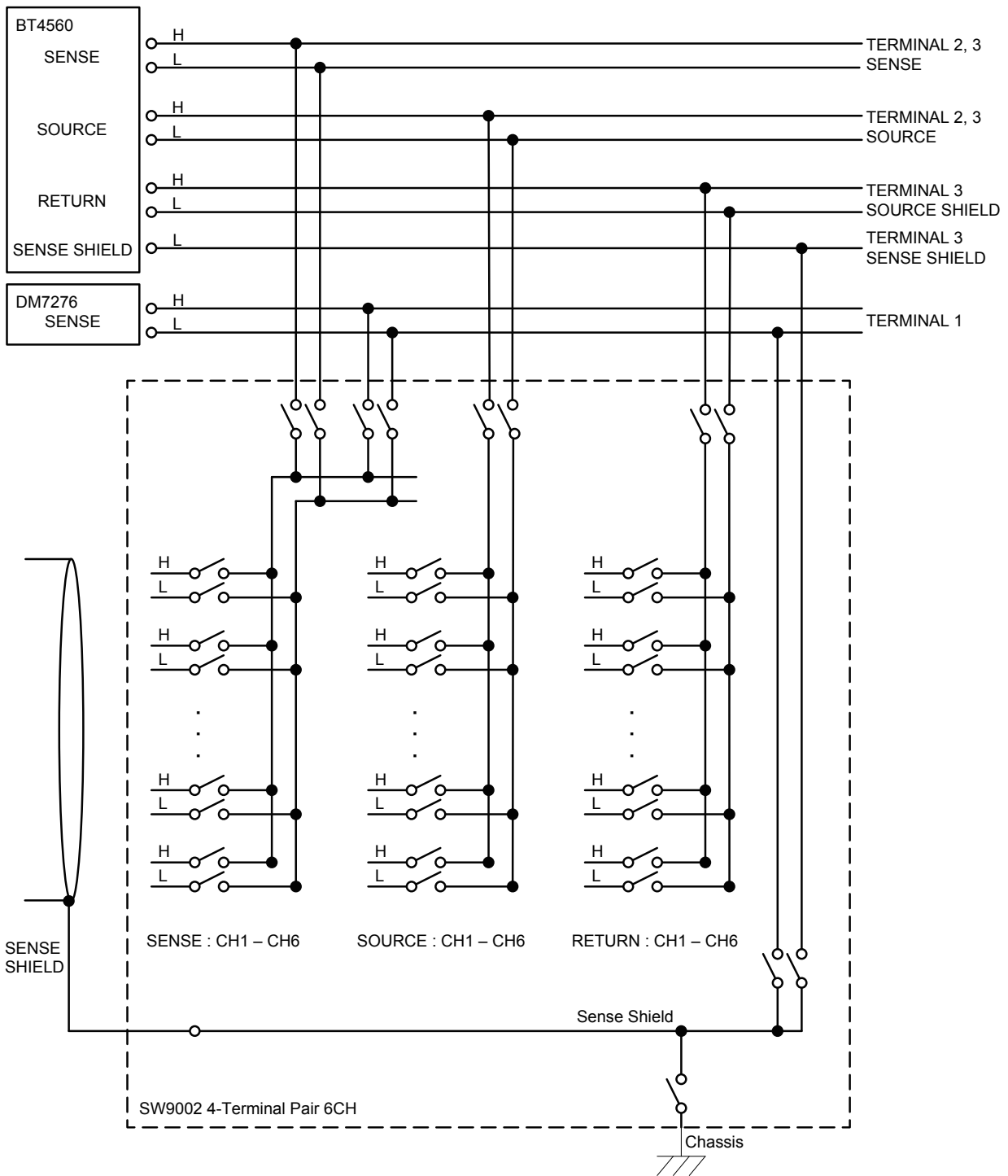

## Connector wiring diagram

### SW9002 connector signal list

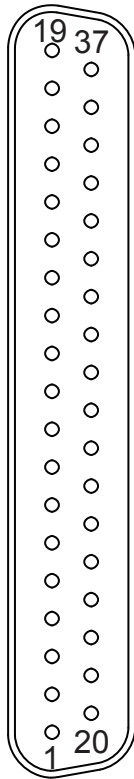

| Pin No. | Signal |     |   | Pin No. | Signal |     |   |
|---------|--------|-----|---|---------|--------|-----|---|
| 19      | Return | CH6 | L | 37      | Source | CH6 | L |
| 18      | Return | CH5 | L | 36      | Source | CH5 | L |
| 17      | Return | CH4 | L | 35      | Source | CH4 | L |
| 16      | Return | CH3 | L | 34      | Source | CH3 | L |
| 15      | Return | CH2 | L | 33      | Source | CH2 | L |
| 14      | Return | CH1 | L | 32      | Source | CH1 | L |
| 13      | Source | CH1 | H | 31      | Return | CH1 | H |
| 12      | Source | CH2 | H | 30      | Return | CH2 | H |
| 11      | Source | CH3 | H | 29      | Return | CH3 | H |
| 10      | Source | CH4 | H | 28      | Return | CH4 | H |
| 9       | Source | CH5 | H | 27      | Return | CH5 | H |
| 8       | Source | CH6 | H | 26      | Return | CH6 | H |
| 7       | Shield |     |   | 25      | Sense  | CH1 | L |
| 6       | Sense  | CH1 | H | 24      | Sense  | CH2 | L |
| 5       | Sense  | CH2 | H | 23      | Sense  | CH3 | L |
| 4       | Sense  | CH3 | H | 22      | Sense  | CH4 | L |
| 3       | Sense  | CH4 | H | 21      | Sense  | CH5 | L |
| 2       | Sense  | CH5 | H | 20      | Sense  | CH6 | L |
| 1       | Sense  | CH6 | H |         |        |     |   |

When using the device as a 2-wire model, only sense CH1 to CH6 are enabled.

The measurement connector frame of the module is connected to the casing (metal) of the device as well as the protective ground terminal of the power inlet (conductive).

## Acquiring the relay opening/closing frequency

You can acquire the relay opening/closing frequency as stored in the module's non-volatile memory. To acquire the relay opening/closing frequency, use :**SYSTem:MODUle:COUNT?** (p.88). Relays are identified by number alone (Relay 1 through Relay 22)

### Correspondence of module relays and relay numbers (SW9002)

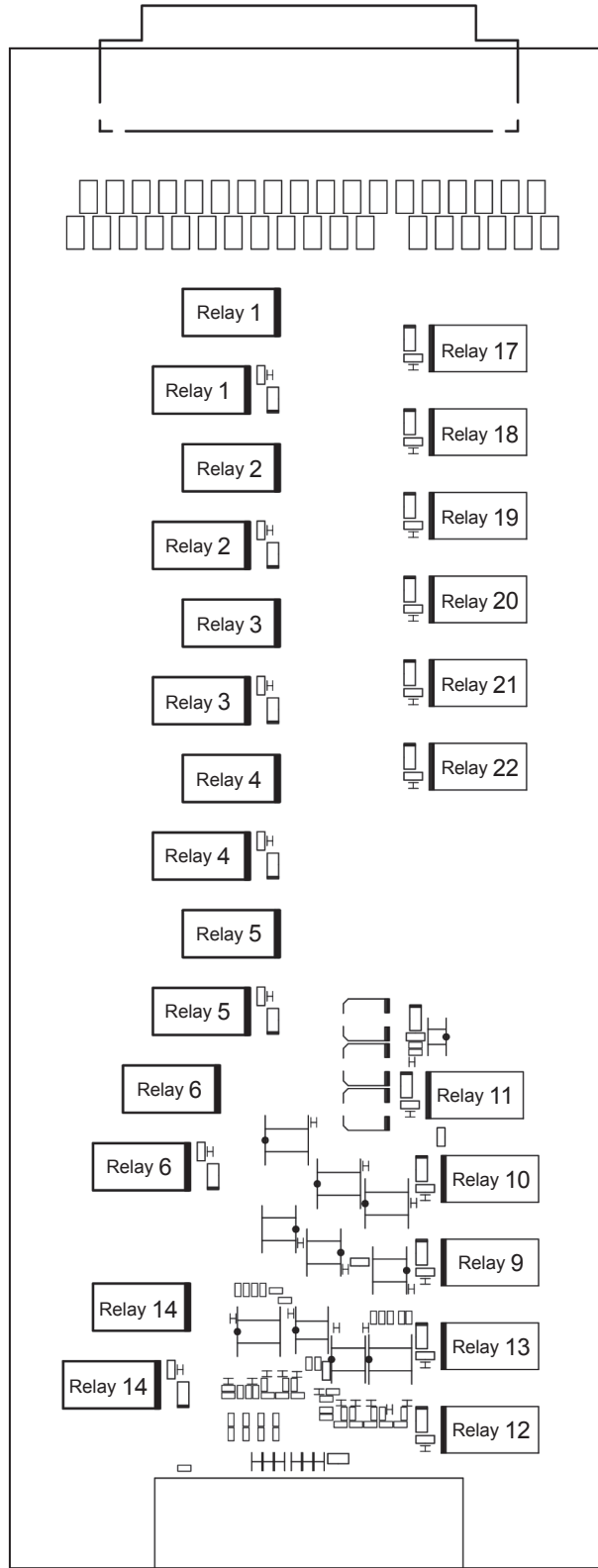

## 11.3 Accuracy Calculation Example

This section describes how to calculate the combined accuracy of the device and a connected measuring instrument.

This process consists of calculating the measurement influence for each measuring instrument (target instrument) used in the combination.

The measurement accuracy when using the device and a module is calculated using the following formula:

Combination measurement accuracy = Instrument accuracy + combination measurement influence

For more information about a given module's measurement influences, see the module's specifications

- SW9001  
"Measurement influence" (p. 131)
- SW9002  
"Measurement influence" (p. 137)

Below shows an example of accuracy calculation.

### Example 1: Use of the device in combination with the BT3562

|                   |  |
|-------------------|--|
| Used module       | SW9001   |
| Instrument        | BT3562 ΩV function, 3 mΩ range, 6 V range, sampling SLOW |
| Measurement value | 1 mΩ, 4 V  |

$$\begin{aligned}
 \text{Resistance measurement accuracy} &= \text{BT3562 resistance measurement accuracy} + \text{SW9001} \\
 &\quad \text{measurement influence (BT3562 3 } \Omega \text{ range)} \\
 &= (\pm 0.5\% \text{ rdg. } \pm 10 \text{ dgt.}) + (\pm 0.1\% \text{ f.s.}) \\
 &= (\pm 0.5\% \times 1 \text{ m}\Omega + 0.0010 \text{ m}\Omega) + \{\pm(0.1\% \times 3.1000 \text{ m}\Omega)\} \\
 &= (\pm 0.0060 \text{ m}\Omega) + (\pm 0.0031 \text{ m}\Omega) \\
 &= \pm 0.0091 \text{ m}\Omega \text{ (total error)}
 \end{aligned}$$

$$\begin{aligned}
 \text{Voltage measurement accuracy} &= \text{BT3562 voltage measurement accuracy} + \text{SW9001} \\
 &\quad \text{measurement influence (all BT3562 voltage ranges)} \\
 &= (\pm 0.01\% \text{ rdg. } \pm 3 \text{ dgt.}) + (\pm 5 \mu\text{V}) \\
 &= (\pm 0.01\% \times 4 \text{ V } \pm 0.00003 \text{ V}) + (\pm 5 \mu\text{V}) \\
 &= (\pm 0.00043 \text{ V}) + (\pm 5 \mu\text{V}) \\
 &= \pm 0.000435 \text{ V (total error)}
 \end{aligned}$$



**Example 2: Use of the device in combination with the BT4560**

Used module            SW9002  
 Instrument            BT4560 RX function, 3 mΩ range, 1000 Hz, sampling SLOW  
 Measurement value    R 1 mΩ, X 0 mΩ

$$\begin{aligned}
 \text{R measurement accuracy} &= \text{BT4560 R measurement accuracy} + \text{SW9002 measurement influence} \\
 &\quad (\text{BT4560 3 m}\Omega \text{ range R}) \\
 &= \{\pm(0.004 |R| + 0.0052 |X|) \pm 8 \text{ dgt.}\} + (\pm 0.1\% \text{ f.s.}) \\
 &= \{\pm(0.004 \times 1 \text{ m}\Omega + 0.0052 \times 0 \text{ m}\Omega) \pm 0.0008 \text{ m}\Omega\} + \{\pm(0.1\% \times \\
 &\quad 3.0000 \text{ m}\Omega)\} \\
 &= (\pm 0.0048 \text{ m}\Omega) + (\pm 0.0030 \text{ m}\Omega) \\
 &= \pm 0.0078 \text{ m}\Omega \text{ (total error)}
 \end{aligned}$$

$$\begin{aligned}
 \text{X measurement accuracy} &= \text{BT4560 X measurement accuracy} + \text{SW9002 measurement influence} \\
 &\quad (\text{BT4560 3 m}\Omega \text{ range X}) \\
 &= \{\pm(0.004 |X| + 0.0052 |R|) \pm 8 \text{ dgt.}\} + (\pm 1.0\% \text{ f.s.}) \\
 &= \{\pm(0.004 \times 0 \text{ m}\Omega + 0.0052 \times 1 \text{ m}\Omega) \pm 0.0008 \text{ m}\Omega\} + \{\pm(1.0\% \times \\
 &\quad 3.0000 \text{ m}\Omega)\} \\
 &= (\pm 0.0052 \text{ m}\Omega) + (\pm 0.0300 \text{ m}\Omega) \\
 &= \pm 0.0352 \text{ m}\Omega \text{ (total error)}
 \end{aligned}$$

**Example 3: Use of the device in combination with the DM7276**

Used module            SW9001  
 Instrument            DM7276 V function, 100 mV range, sampling MEDIUM  
 Measurement value    100 mV

$$\begin{aligned}
 \text{Voltage measurement accuracy} &= \text{DM7276 voltage measurement accuracy} + \text{SW9001} \\
 &\quad \text{measurement influence (all DM7276 voltage ranges)} \\
 &= (\pm 0.0015\% \text{ rdg.} \pm 2 \mu\text{V}) + (\pm 7 \mu\text{V}) \\
 &= (\pm 0.0015\% \times 100 \text{ mV} \pm 2 \mu\text{V}) + (\pm 7 \mu\text{V}) \\
 &= (\pm 0.0035 \text{ mV}) + (\pm 7 \mu\text{V}) \\
 &= \pm 0.0105 \text{ mV (total error)}
 \end{aligned}$$

# 12 Appendix

## 12.1 Measurement cable

### D-sub 50-pin - Bare end

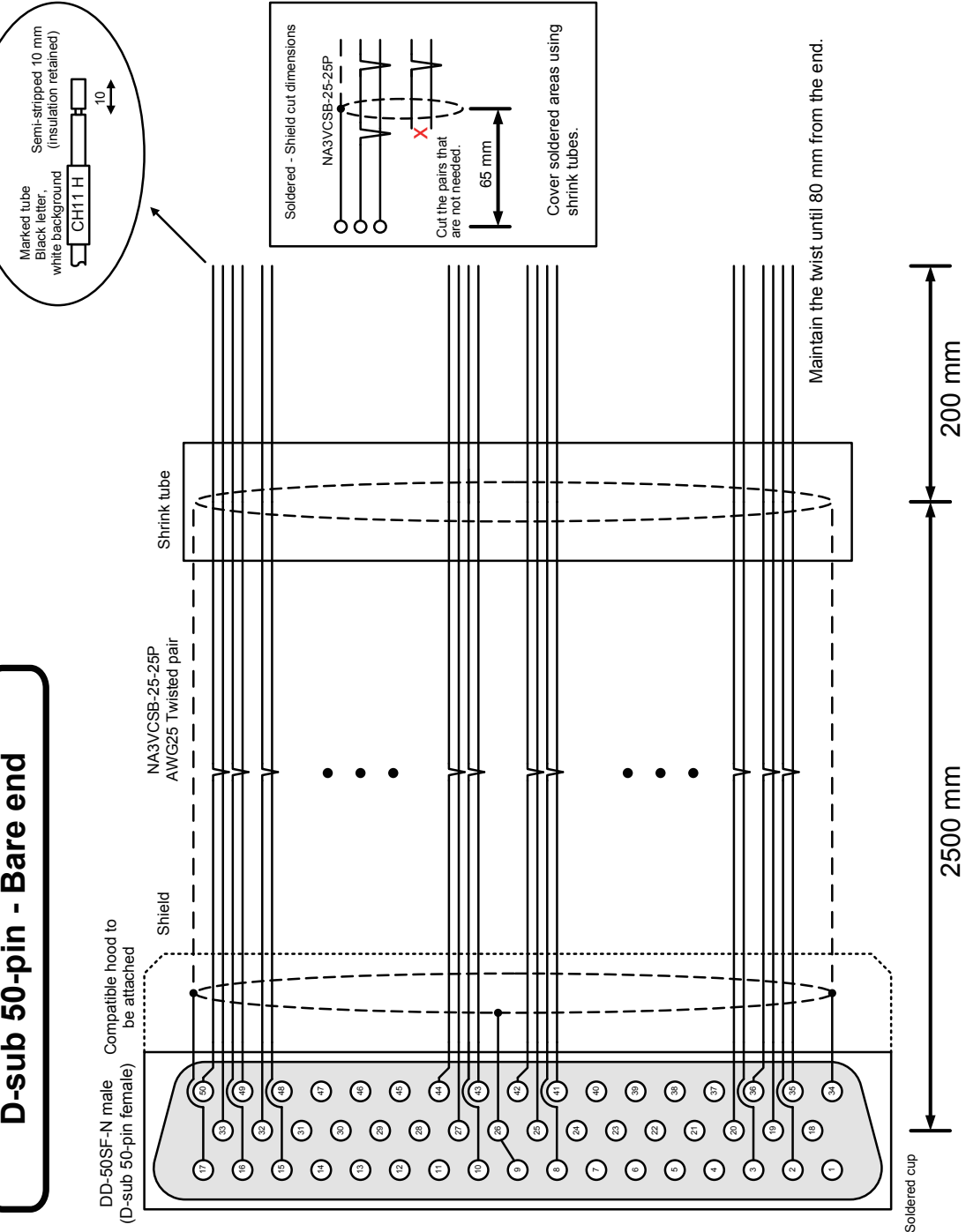

| Dsub50 Female | AWG25        | Cable end Label letter |
|---------------|--------------|------------------------|
| 33            | Twisted pair | CH11 H                 |
| 50            | Twisted pair | CH11 L                 |
| 16            | Twisted pair | CH10 H                 |
| 49            | Twisted pair | CH10 L                 |
| 15            | Twisted pair | CH9 H                  |
| 32            | Twisted pair | CH9 L                  |
| 31            | Twisted pair | CH8 H                  |
| 48            | Twisted pair | CH8 L                  |
| 14            | Twisted pair | CH7 H                  |
| 47            | Twisted pair | CH7 L                  |
| 13            | Twisted pair | CH6 H                  |
| 30            | Twisted pair | CH6 L                  |
| 29            | Twisted pair | CH5 H                  |
| 46            | Twisted pair | CH5 L                  |
| 12            | Twisted pair | CH4 H                  |
| 45            | Twisted pair | CH4 L                  |
| 11            | Twisted pair | CH3 H                  |
| 28            | Twisted pair | CH3 L                  |
| 27            | Twisted pair | CH2 H                  |
| 44            | Twisted pair | CH2 L                  |
| 10            | Twisted pair | CH1 H                  |
| 43            | Twisted pair | CH1 L                  |
| 25            | Twisted pair | CH22 H                 |
| 42            | Twisted pair | CH22 L                 |
| 8             | Twisted pair | CH21 H                 |
| 41            | Twisted pair | CH21 L                 |
| 24            | Twisted pair | CH20 H                 |
| 7             | Twisted pair | CH20 L                 |
| 23            | Twisted pair | CH19 H                 |
| 40            | Twisted pair | CH19 L                 |
| 6             | Twisted pair | CH18 H                 |
| 39            | Twisted pair | CH18 L                 |
| 5             | Twisted pair | CH17 H                 |
| 22            | Twisted pair | CH17 L                 |
| 21            | Twisted pair | CH16 H                 |
| 38            | Twisted pair | CH16 L                 |
| 4             | Twisted pair | CH15 H                 |
| 37            | Twisted pair | CH15 L                 |
| 3             | Twisted pair | CH14 H                 |
| 20            | Twisted pair | CH14 L                 |
| 19            | Twisted pair | CH13 H                 |
| 36            | Twisted pair | CH13 L                 |
| 2             | Twisted pair | CH12 H                 |
| 35            | Twisted pair | CH12 L                 |
| 17            | -            | -                      |
| 26            | -            | -                      |
| 9             | Shield       | -                      |
| 1             | -            | -                      |
| 18            | -            | -                      |
| 34            | -            | -                      |

Recommended cable length of less than 3 m.

# D-sub 37-pin - Bare end

DC-37SF-N Female + equivalent to hood JAE DC-24660R  
(D-sub 37 Female)

Cover soldered areas using shrink tubes.

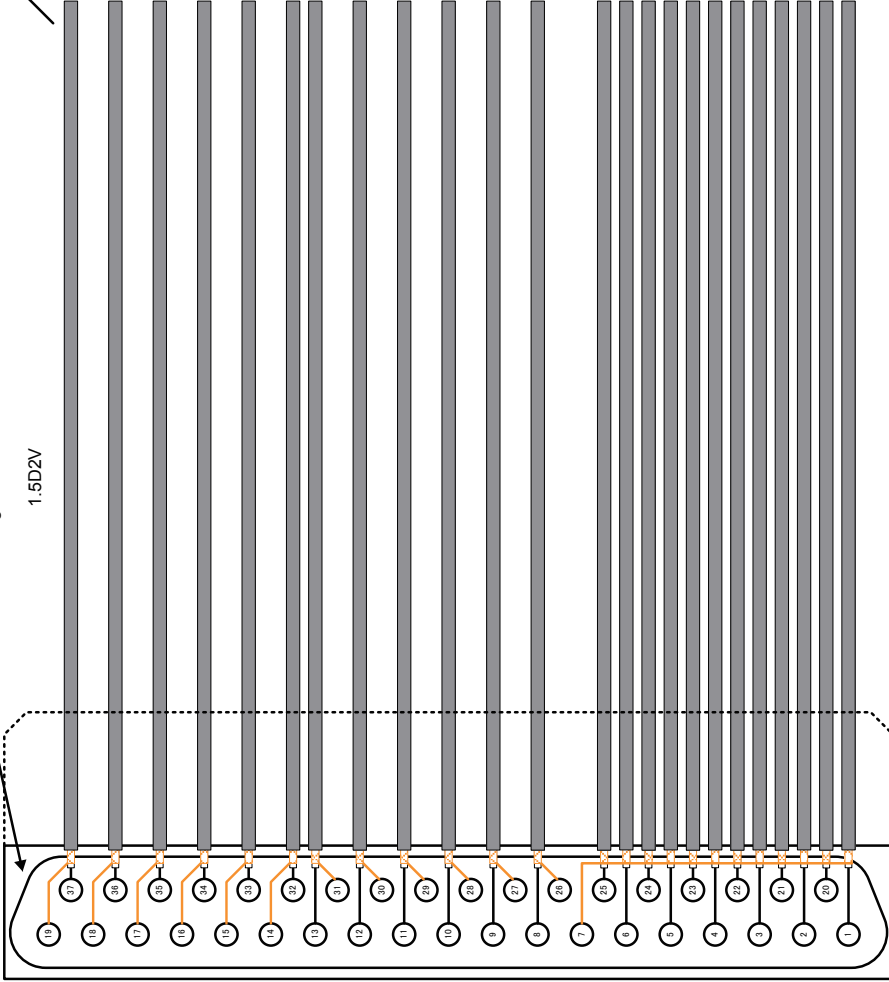

| Dsub37 Female | 1.5D2V    | Cable end Marking letter |
|---------------|-----------|--------------------------|
| 19            | Shield    | CH6 SRC-L                |
| 37            | Core wire | CH6 SRC-L                |
| 18            | Shield    | CH5 SRC-L                |
| 36            | Core wire | CH5 SRC-L                |
| 17            | Shield    | CH4 SRC-L                |
| 35            | Core wire | CH4 SRC-L                |
| 16            | Shield    | CH3 SRC-L                |
| 34            | Core wire | CH3 SRC-L                |
| 15            | Shield    | CH2 SRC-L                |
| 33            | Core wire | CH2 SRC-L                |
| 14            | Shield    | CH1 SRC-L                |
| 32            | Core wire | CH1 SRC-L                |
| 13            | Core wire | CH1 SRC-H                |
| 31            | Shield    | CH1 SRC-H                |
| 12            | Core wire | CH2 SRC-H                |
| 30            | Shield    | CH2 SRC-H                |
| 11            | Core wire | CH3 SRC-H                |
| 29            | Shield    | CH3 SRC-H                |
| 10            | Core wire | CH4 SRC-H                |
| 28            | Shield    | CH4 SRC-H                |
| 9             | Core wire | CH5 SRC-H                |
| 27            | Shield    | CH5 SRC-H                |
| 8             | Core wire | CH6 SRC-H                |
| 26            | Shield    | CH6 SRC-H                |
| 7             | Shield    | -                        |
| 25            | Core wire | CH1 SNS-L                |
| 6             | Core wire | CH1 SNS-H                |
| 24            | Core wire | CH2 SNS-L                |
| 5             | Core wire | CH2 SNS-H                |
| 23            | Core wire | CH3 SNS-L                |
| 4             | Core wire | CH3 SNS-H                |
| 22            | Core wire | CH4 SNS-L                |
| 3             | Core wire | CH4 SNS-H                |
| 21            | Core wire | CH5 SNS-L                |
| 2             | Core wire | CH5 SNS-H                |
| 20            | Core wire | CH6 SNS-L                |
| 1             | Core wire | CH6 SNS-H                |

2700 mm  
Recommended cable length of less than 3 m.

## 12.2 Measuring Object Short Circuit due to Relay Contact Welding

The SW9001 and SW9002 multiplexer modules switch a measurement signal using a mechanical relay.

The relay contact may weld when relay switching is repeated with a large current flowing (also when the measuring object or instrument to be connected is capacitive). When relay contact welding occurs, the measuring object may be shorted. Periodic inspection is recommended. Reference: "Checking for relay contact welding" (p.26)

**Example: When a battery cell is measured with the cell reversed**

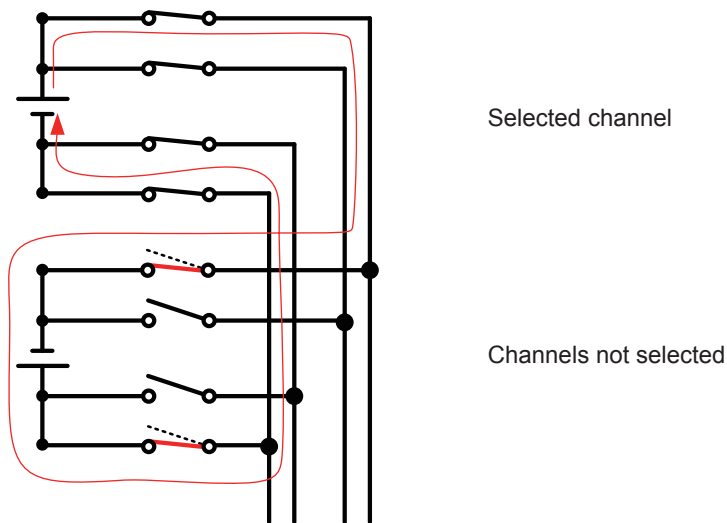

**Example: When each of the stacked batteries is measured**

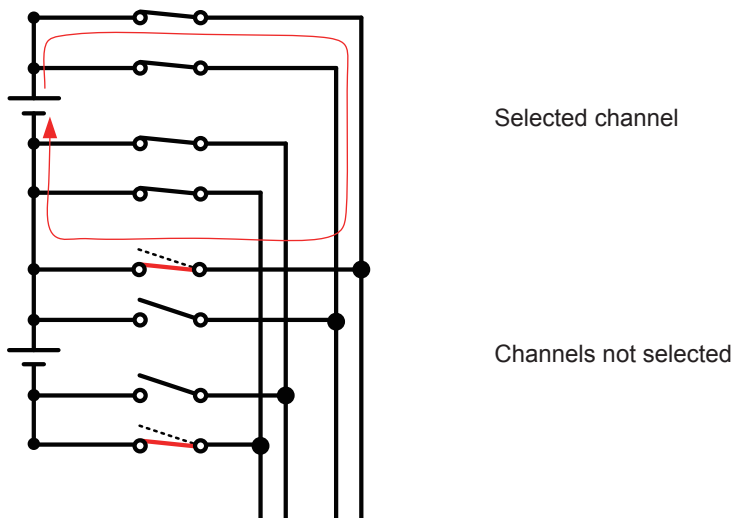

**Module fuse rating**

The SW9001 and SW9002 are provided with a fuse (board mounted type) in HIGH and LOW for each channel input to prevent possible risks if a high current flows through the circuit due to relay contact welding.

| Module | Channel        | Rated current | Fusing current |
|--------|----------------|---------------|----------------|
| SW9001 | All channels   | 1.6 A DC      | 4.0 A DC       |
| SW9002 | Sense channel  | 1.6 A DC      | 4.0 A DC       |
|        | Source channel | 2.5 A DC      | 6.25 A DC      |
|        | Return channel | 2.5 A DC      | 6.25 A DC      |

## 12.3 Rack Mount

A rack mount bracket can be attached if screws are removed from the side of the device.

### **WARNING**



To prevent device damage or an electric shock, use only the screws that are originally installed. (Side: M3 × 6 mm, when the rack mount bracket is attached: M3 × 8 mm )

If you have lost a screw or find that a screw is damaged, please contact your authorized Hioki distributor or reseller.

# Rack mount bracket

For SW1001, EIA

Unit: mm

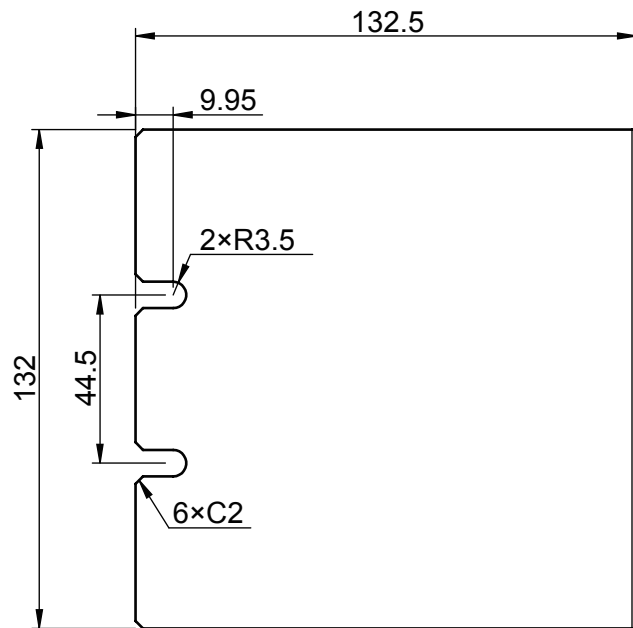
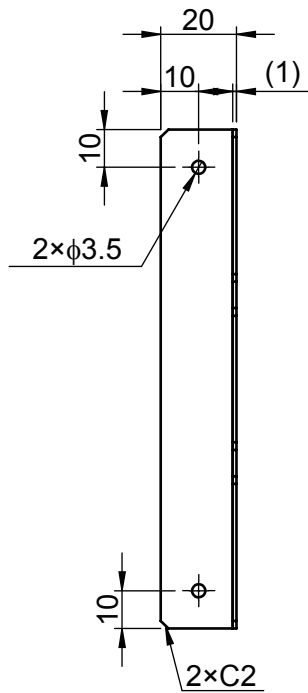

For SW1001, JIS

Unit: mm

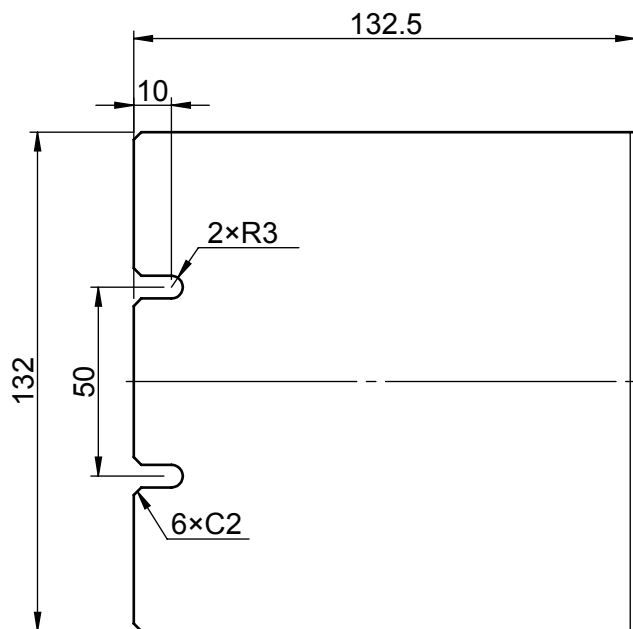
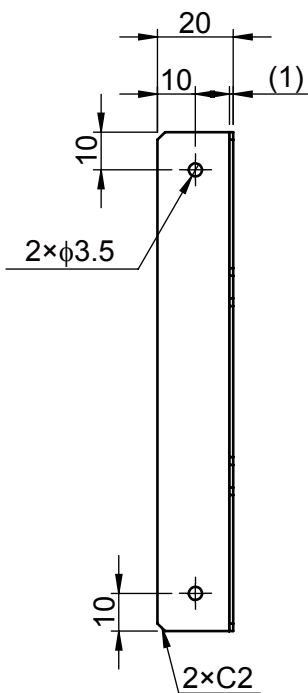

For SW1002, EIA

Unit: mm

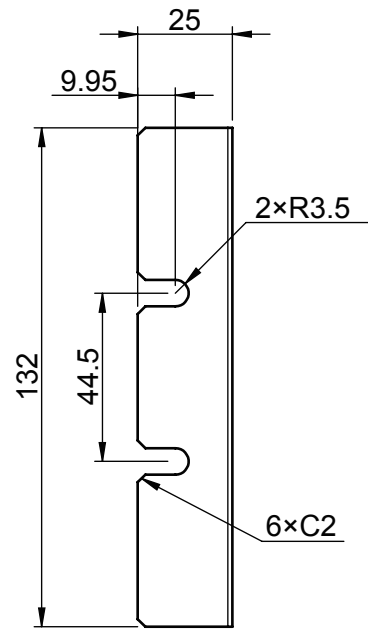
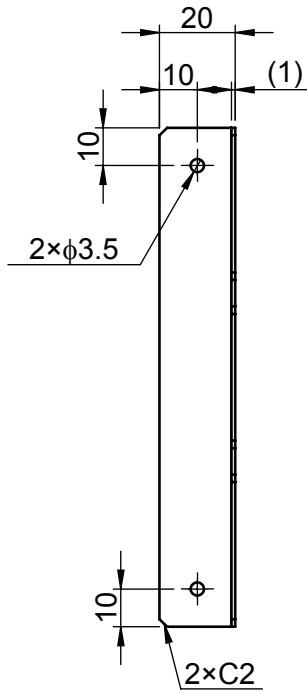

For SW1002, JIS

Unit: mm

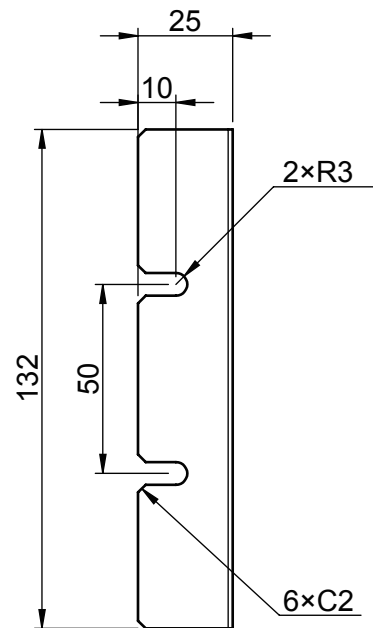
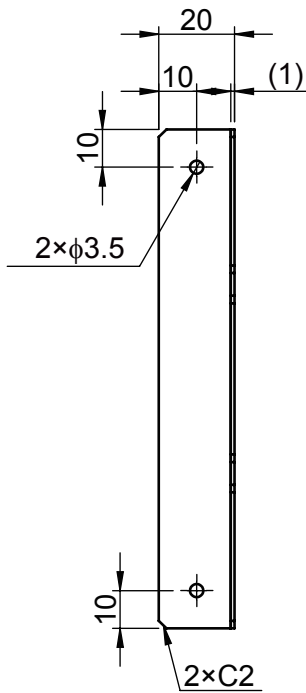



### Attachment procedure (Example: SW1001)

All screws are M3 × 6 mm.

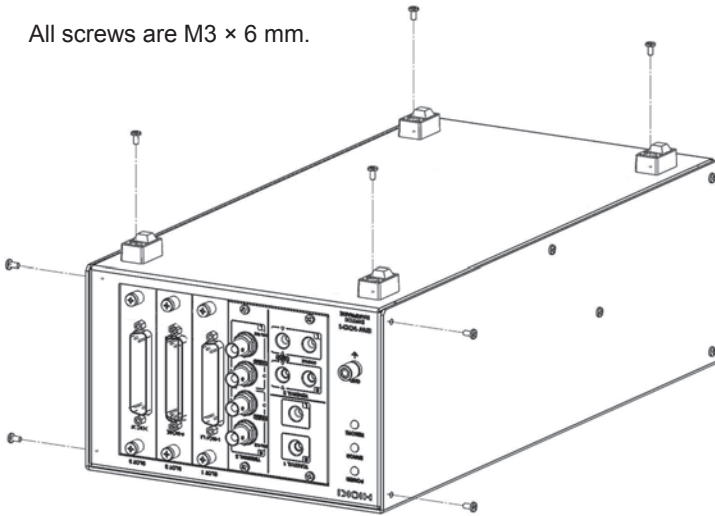

**1** Remove the four screws shown in the figure and remove the rubber feet from the bottom.

**2** Remove the screws on the left and right sides shown in the figure (two screws each toward the front).

Rack mount bracket (EIA, JIS)

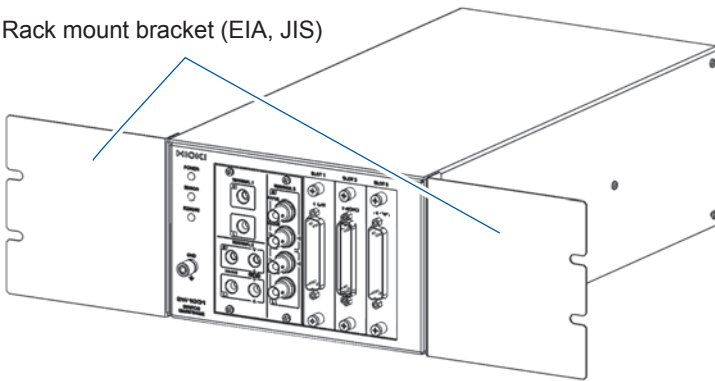

**3** Attach the rack mount bracket. Use M3 × 8 screws on the left and right side at the front of the device.

When mounting the device on a rack, use a commercially available base for reinforcement.

## L-shape bracket (For installing the module in automated equipment)

### L-shape bracket

Unit: mm

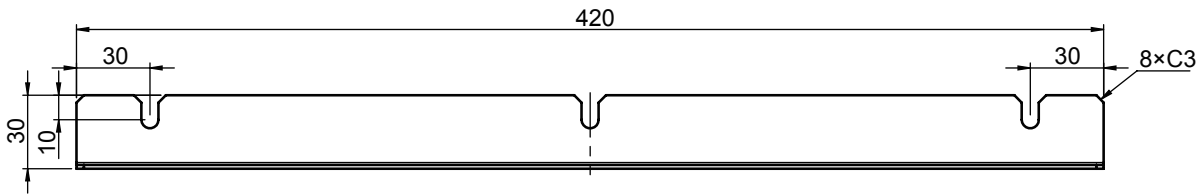

Note: Align the holes with the base prepared by the customer.

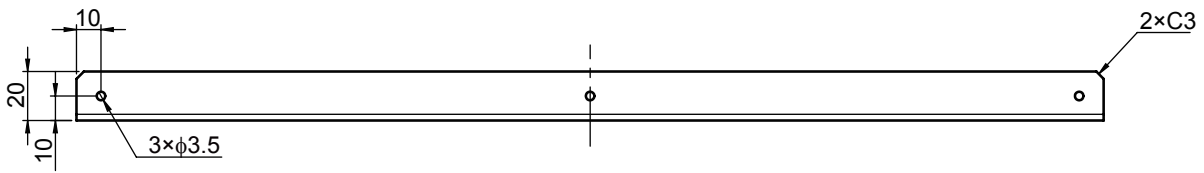

### Attachment procedure (Example: SW1001)

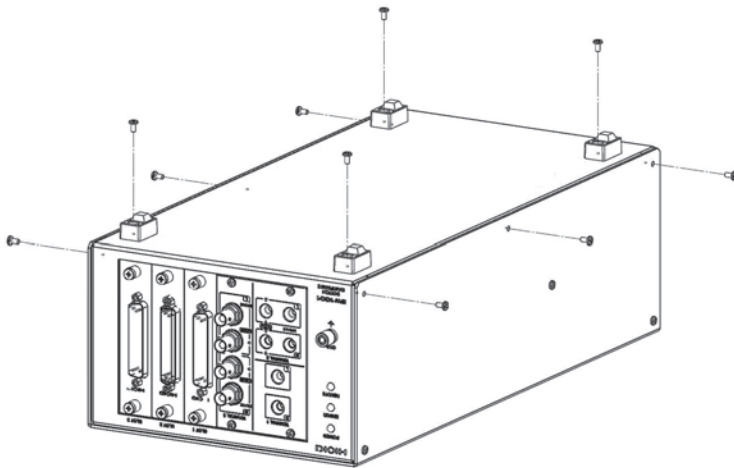

- 1** Remove the four screws shown in the figure and remove the rubber feet from the bottom.
- 2** Remove the screws on the left and right sides shown in the figure (three screws each)

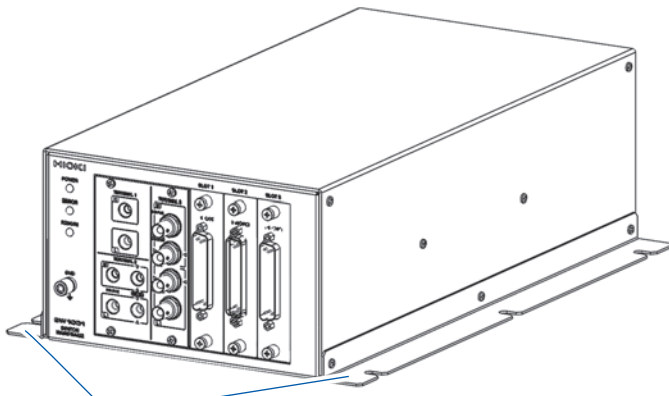

L-shape bracket

- 3** Attach the L-shape bracket.  
Use M3 × 8 screws for three places each on the left and right sides to secure the bracket.
- 4** Secure it to a base.

# 12.4 Outline Drawings

## SW1001

Unit: mm

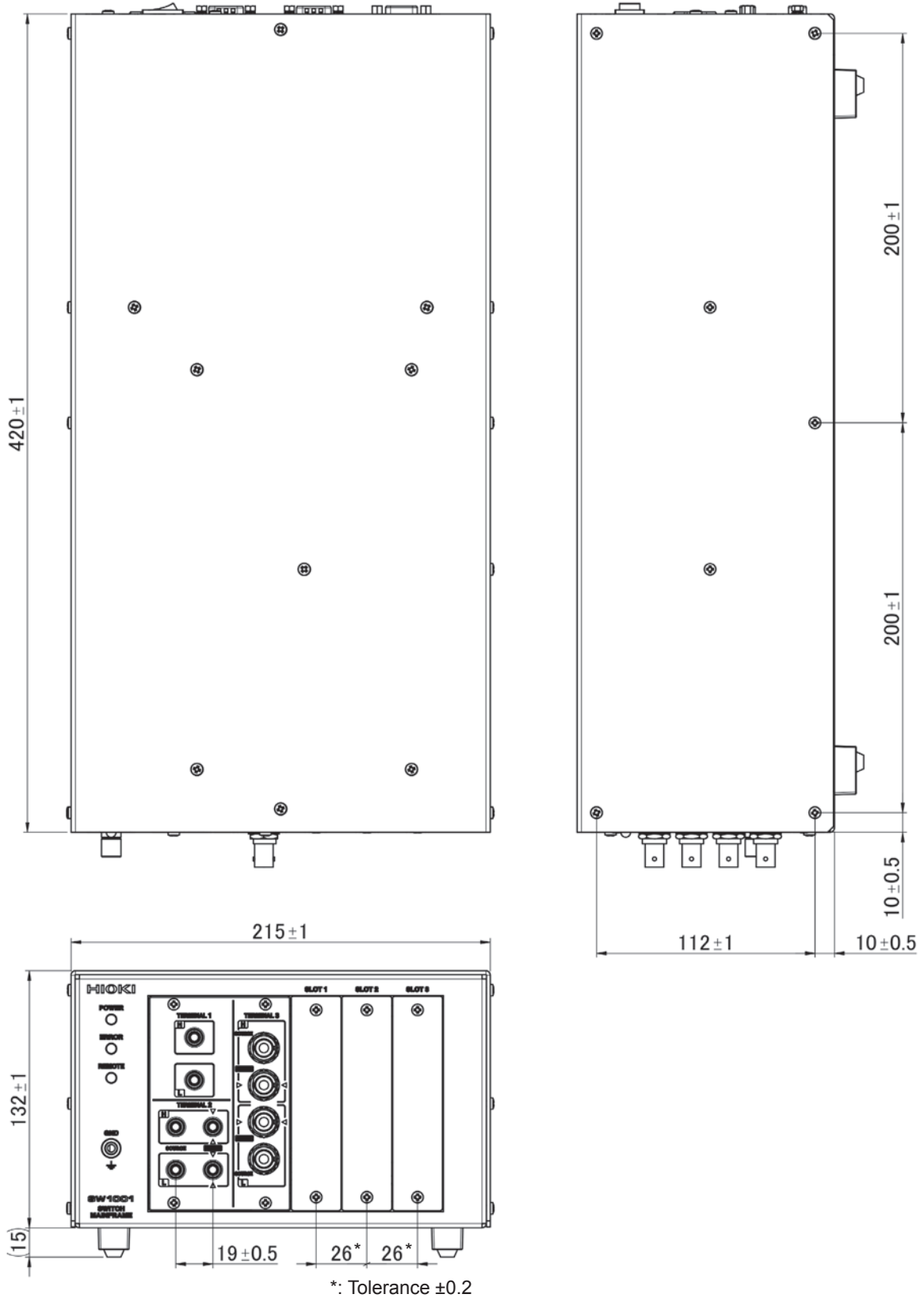

SW1002

Unit: mm

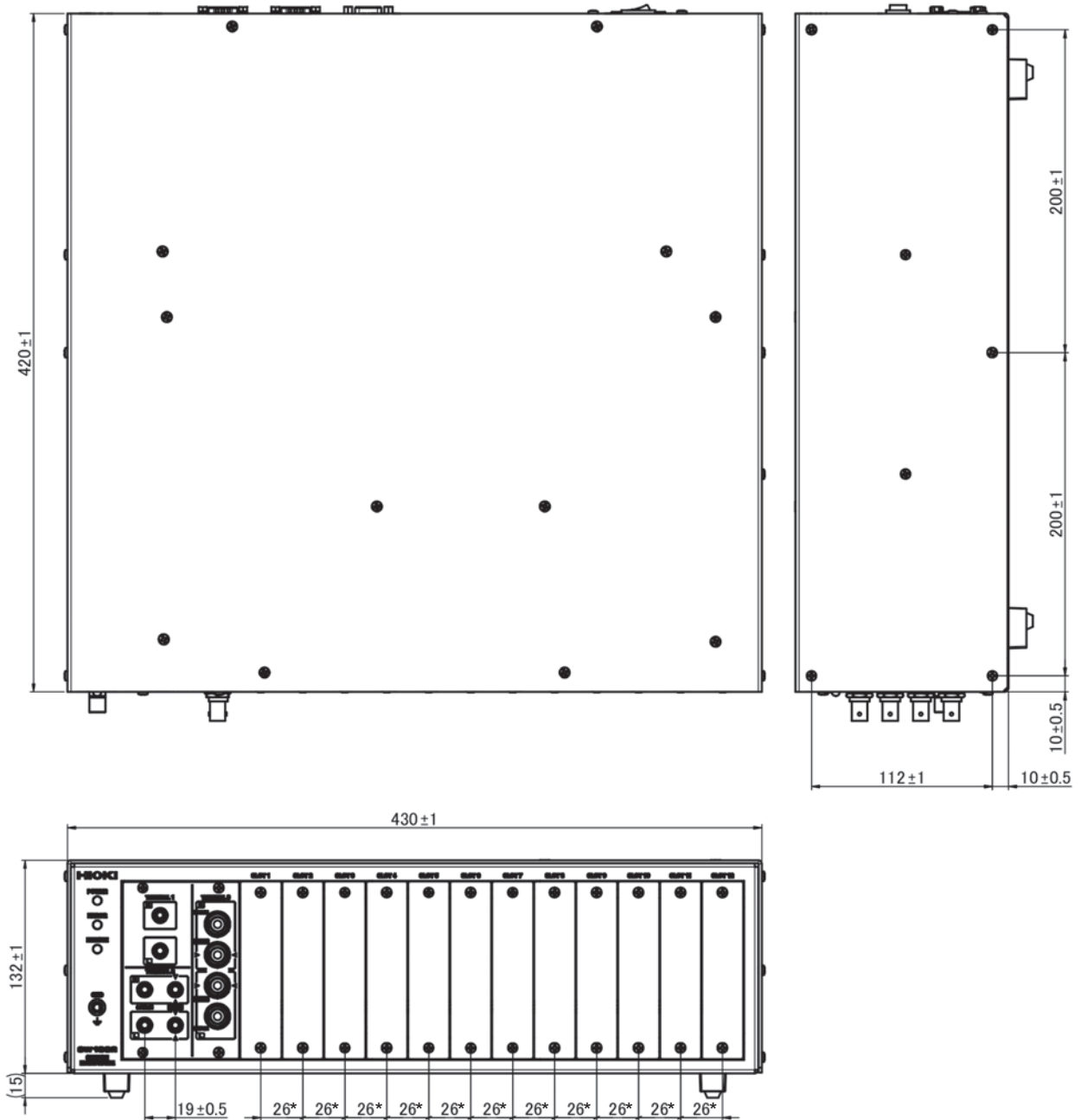

\*: Tolerance  $\pm 0.2$



# Index

## Number

|                 |    |
|-----------------|----|
| 10BASE-T.....   | 60 |
| 100BASE-TX..... | 60 |

## A

|                 |    |
|-----------------|----|
| Analog bus..... | 11 |
|-----------------|----|

## B

|                    |    |
|--------------------|----|
| Backup.....        | 47 |
| Blank panel.....   | 15 |
| Block diagram..... | 10 |
| Bus relay.....     | 11 |

## C

|  |        |
|--|--------|
| Channel delay.....                     | 37     |
| Channel relay.....                     | 11     |
| Command.....                           | 71     |
| Command forwarding function.....       | 101    |
| Command syntax.....                    | 72     |
| Communication command port No.....     | 62     |
| Communication setting mode.....        | 22, 59 |
| Communication setting mode switch..... | 9      |
| Connect                                |        |
| Connection cable.....                  | 19     |
| Measurement cable.....                 | 18     |
| Power cord.....                        | 23     |
| Connection cable.....                  | 11, 19 |
| Connection method.....                 | 11     |
| Connector wiring diagram (SW9001)..... | 133    |
| Connector wiring diagram (SW9002)..... | 139    |
| CR.....                                | 73     |
| CR+LF.....                             | 73     |

## D

|                 |          |
|-----------------|----------|
| Delay time..... | 37       |
| DFLT.....       | 22       |
| Dimensions      |          |
| Device.....     | 119      |
| Module.....     | 129, 135 |

## E

|  |     |
|--|-----|
| End channel.....                       | 40  |
| ERROR.....                             | 126 |
| Error display and troubleshooting..... | 126 |
| Error information.....                 | 100 |
| Error number.....                      | 127 |
| Ethernet.....                          | 60  |
| Event Registers.....                   | 77  |

|                                       |       |
|---------------------------------------|-------|
| External control.....                 | 49    |
| External trigger.....                 | 39    |
| EXT. I/O MODE.....                    | 9, 50 |
| EXT. I/O MODE change-over switch..... | 9, 50 |
| EXT. I/O terminal.....                | 9     |

## F

|                         |     |
|-------------------------|-----|
| Filter function.....    | 102 |
| Fixed setting mode..... | 22  |
| Fuse.....               | 146 |

## G

|                |    |
|----------------|----|
| Gateway.....   | 62 |
| Glossary.....  | 11 |
| Grounding..... | 49 |

## H

|                   |    |
|-------------------|----|
| Header.....       | 72 |
| HOST RS-232C..... | 66 |

## I

|                                    |    |
|------------------------------------|----|
| Initialization.....                | 47 |
| Initialization settings.....       | 47 |
| Input buffer.....                  | 76 |
| Input signal.....                  | 52 |
| Inspection before measurement..... | 25 |
| Installation.....                  | 64 |
| INSTRUMENT RS-232C.....            | 70 |
| Internal circuit configuratio..... | 55 |
| Connection examples.....           | 57 |
| Electrical specification.....      | 56 |
| IP address.....                    | 62 |
| Isolated power supply output.....  | 52 |

## L

|                    |    |
|--------------------|----|
| LAN interface..... | 60 |
|--------------------|----|

## M

|                            |          |
|----------------------------|----------|
| Mass                       |          |
| Device.....                | 119      |
| Module.....                | 129, 135 |
| Maximum input voltage..... | 120      |
| Measurement cable.....     | 11, 18   |
| Measurement flowchar.....  | 12       |
| Message terminator.....    | 73       |
| Module information.....    | 45, 105  |

**N**

|                       |        |
|-----------------------|--------|
| Network .....         | 60     |
| NPN .....             | 49, 50 |
| NPN/PNP .....         | 50     |
| NRf .....             | 74     |
| Number of slots ..... | 120    |

**O**

|                        |     |
|------------------------|-----|
| Options .....          | 2   |
| Outline drawings ..... | 152 |
| Output queue .....     | 76  |
| Output signal .....    | 52  |

**P**

|                    |        |
|--------------------|--------|
| PNP .....          | 49, 50 |
| Port No. ....      | 62     |
| Power supply       |        |
| Off .....          | 23     |
| On .....           | 23     |
| Power switch ..... | 9      |

**Q**

|             |    |
|-------------|----|
| Query ..... | 71 |
|-------------|----|

**R**

|                                       |                   |
|---------------------------------------|-------------------|
| Rack mount .....                      | 147               |
| Relay contact welding .....           | 26                |
| Relay opening/closing frequency ..... | 45, 106, 134, 140 |
| Relay operation time .....            | 35                |
| Remote state .....                    | 86                |
| Repair .....                          | 128               |
| Replacement parts .....               | 128               |
| Response message .....                | 72                |
| RS-232C connector .....               | 9                 |
| RS-232C interface .....               | 66                |

**S**

|                               |     |
|-------------------------------|-----|
| Sample program .....          | 107 |
| Scan .....                    | 11  |
| Scan list .....               | 40  |
| SCAN_RESET signal .....       | 42  |
| SCAN signal .....             | 41  |
| Self-test .....               | 23  |
| Separator .....               | 73  |
| Settling time .....           | 35  |
| Sinking current (NPN) .....   | 50  |
| Sinking current output .....  | 49  |
| Sourcing current output ..... | 49  |
| Sourcing current (PNP) .....  | 50  |

|   |     |
|---|-----|
| Specification .....                     | 119 |
| Standard Event Status Register .....    | 80  |
| Start channel .....                     | 40  |
| Status Byte Register .....              | 77  |
| Subnet mask .....                       | 62  |
| Switching wiring diagram (SW9001) ..... | 132 |
| Switching wiring diagram (SW9002) ..... | 138 |
| Synchronized command .....              | 92  |

**T**

|                    |    |
|--------------------|----|
| Terminal .....     | 11 |
| TERMINAL 1 .....   | 20 |
| TERMINAL 2 .....   | 20 |
| TERMINAL 3 .....   | 21 |
| Timing chart ..... | 53 |

**U**

|                         |    |
|-------------------------|----|
| Uninstallation .....    | 64 |
| USB driver .....        | 64 |
| USB interface .....     | 64 |
| USER .....              | 22 |
| User setting mode ..... | 22 |

