

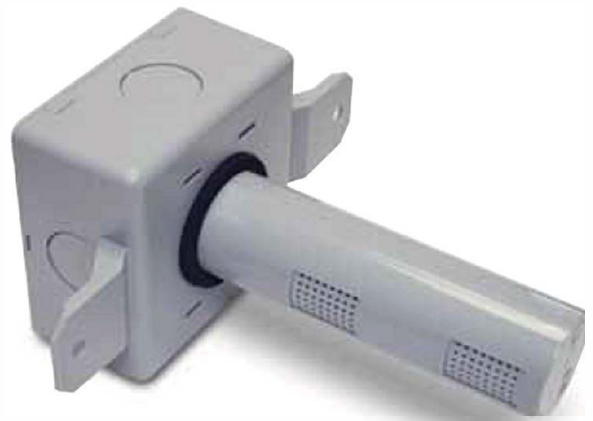

Ventostat[®] T8041/T8042

Telaire CO₂ Duct Probe Transmitters

Telaire is excited to announce to announce a new generation of Telaire CO₂ transmitters targeting indoor air quality and energy conservation applications. The Ventostat[®] T8041/T8042 duct mount CO₂ transmitters offer accuracy and versatility at an affordable price. This exceptional product line touts an unobtrusive form factor that is easy to install, simple to use, and remains accurate over the expected life of the device using Telaire's patented ABC Logic[™] (Automatic Background Calibration) technology.



Features

- Simple installation (mounting hardware and instructions included)
- Two models with different probe lengths to suit a variety of return air duct sizes
- Offers standard 0-10 volt or 0-5 volt output
- Patented absorption infrared/gas sensing engine provides high accuracy in a compact low-cost package
- Patented ABC Logic[™] self-calibration system eliminates the need for manual calibration in most applications
- Gas permeable, water resistant diffusion filter prevents particulate and water contamination of the sensor
- RoHS compliant
- Lifetime calibration guarantee (ABC Logic[™] on)

Applications

CO₂ transmitters can be used in a broad range of applications including air quality monitoring in buildings. CO₂ concentration levels in buildings are monitored to provide an indication of occupancy and to drive a ventilation control strategy. An effective DCV (Demand Controlled Ventilation) strategy will conserve energy and maintain indoor air quality.

Installation Instructions

1. Before installing the sensor, note the direction of the airflow.
2. Drill/cut one [38.10 mm] 1 1/2" hole. Punch/drill two [3.17 mm] 1/8" holes for mounting screws.
3. Slide sensor into [38.10 mm] 1 1/2" hole and secure with screws.
4. Connect the conduit and make necessary wire connections.
5. Install lid, and ensure it snaps into place.

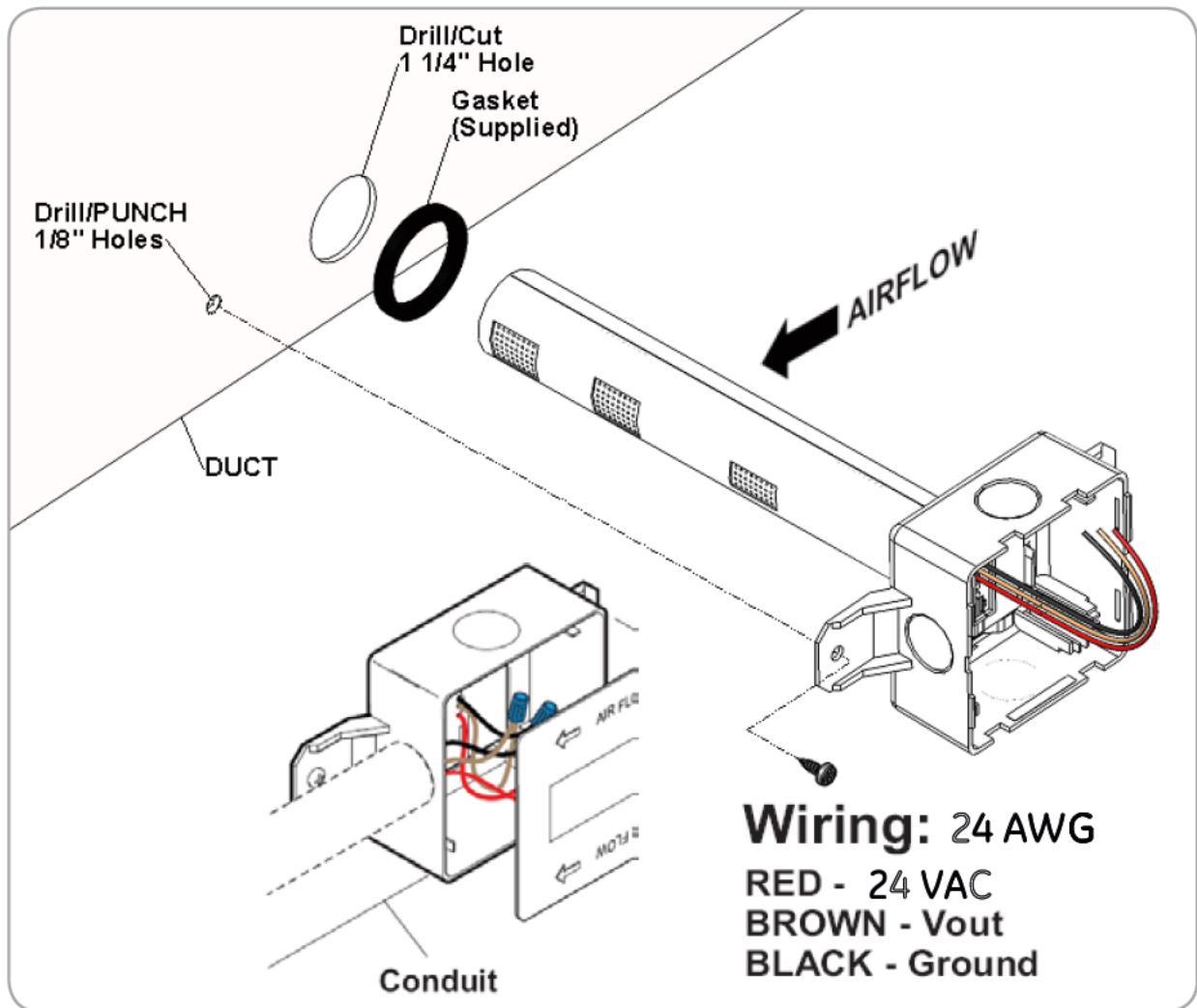

Installation Drawing for T8041 and T8042 (T8042 Installation shown)

Dimensional Drawings

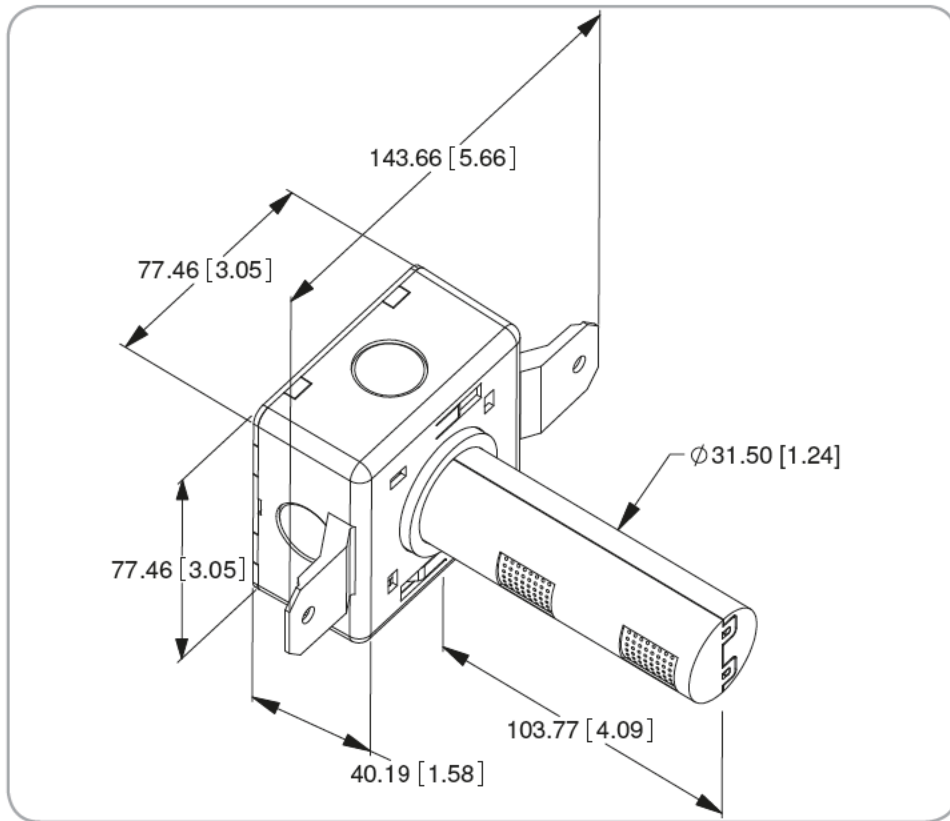

T8041 Dimensions (All Dimensions are in MM [Inch].)

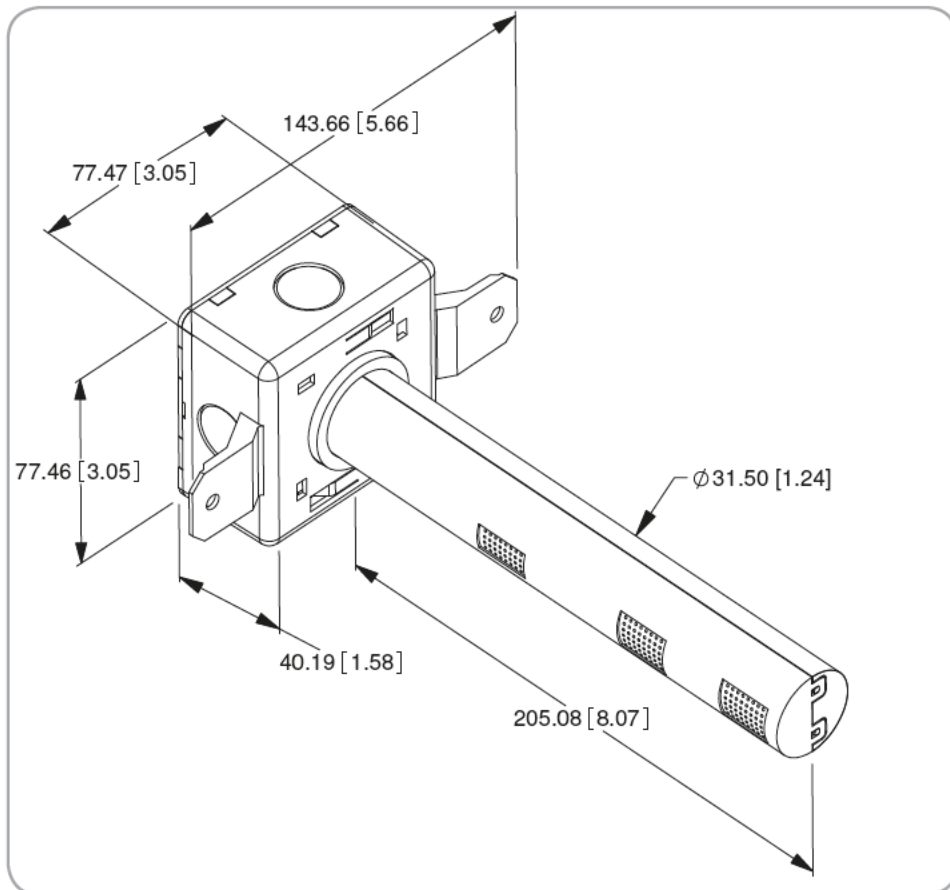

T8042 Dimensions (All Dimensions are in MM [Inch].)

Model T8041/T8042 Specifications

Technology

The technology is based on the absorption of light in a gold-plated reflective light pipe or waveguide diffusion gas chamber. A gas permeable PTFE filter prevents particulate and water contamination of the sensor. Light is absorbed in proportion to the CO₂ concentration and the remaining light is measured and converted into an analog signal.

Measurement Range

0-2000 PPM factory calibrated

Part Numbers

T8041 (0-10V), T8041-5V (0-5V), T8042 (0-10V), T8042-5V (0-5V)

Duct Air Velocity

0 to 1500 ft/min (0 to 450 meter/min)

Temp Dependence

0.2% of full scale per °C

Stability

<2% of full scale over the life of the sensor (10 years typical)

*Accuracy

±40 ppm +3% of reading @ 22°C (72°F) when compared with a factory certified reference

Non-linearity

<1% of full scale @ 22°C (72°F)

Pressure Dependence

0.13% of reading per mm of mercury

*Calibration

Sensors will be calibrated at zero and span at the factory. Calibration in the field will not be required. Sensors will be shipped with ABC Logic™ turned on.

Response Time

Three minutes typical for a 90% step change at low duct speeds

Sampling Rate

Every two seconds

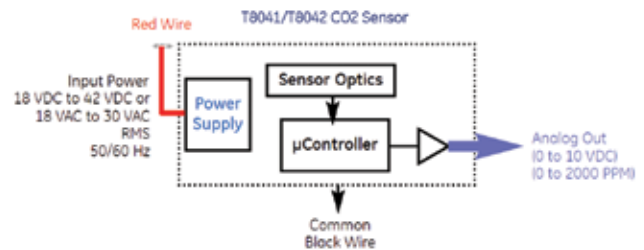

Certifications

RoHS compliance

FCC Part 15,B

CE EMC EN61000-6-2, class B, criterion B*

*Deviations of the output signal may occur during strong electrical fast transients on the power line
Enclosure flammability rating – UL94-5VA

Warm-up Time

< two minutes (operational); 10 minutes to achieve maximum accuracy

Operating Conditions

- Temperature: 0°C to 50°C (32°F to 122°F)
- Humidity: 0 to 95% relative humidity, non-condensing

Storage Conditions

-40°C to 70°C (-40°F to 158°F)

Output

- Analog: 0 to 10V or 0 to 5V

Power Supply Requirements

18 to 30 VAC RMS, 50/60 Hz or 18 to 42 VDC, polarity protected.

Power Consumption

Typical values (1.65 watts peak, 0.65 watts avg. @ 42 VDC)

**Note: The Telaire product line offers patented ABC Logic™ software for self-correction of drift to better than ±20 ppm per year. The system is virtually free of maintenance and typically has a lifetime of more than 10 years.*

Physical Requirements

Dimensions:

Probe Length : T8041 4.09 in (10.38 cm)

T8042 8.07 in (20.51 cm)

Probe Diameter : 1.24 in (3.15 cm)

Junction Box Depth : 1.58 in (4.02 cm)

Junction Box H x L: 3.05 in x 3.05 in (7.46 cm x 7.46 cm)

Color: Grey (GY6275)

Installation Kit

Included with the transducer are wire nuts, mounting screws and installation instructions.