

GE
Measurement & Control Solutions

T8700 Wall Mount

Telaire Wall Mount Humidity and Temperature Transmitters



Features:

- Precision humidity and temperature transmitter for HVAC control applications
- Mounting plate with two-piece terminal blocks provide quick, easy wiring.
- Gas permeable, water resistant humidity sensor filter prevents particulate and water contamination of the sensor.
- Field replaceable humidity sensor
- Locking screw secures cover and sensor to the mounting bracket for tamper resistance.
- Analog outputs 0-5, 0-10V, 4-20 mA
- Display and non-display versions
- Sensors are shipped factory calibrated.
- Active and passive temperature sensor outputs on all models.
- Modern enclosure with customized branding available.
- Two available sizes



Part Number	Size	Display	Humidity Output			Temp Output 0-50 °C			Thermistor 10k II
			4-20 mA	0-5 V	0-10 V	4-20 mA	0-5 V	0-10 V	
T8700-E	Euro	No	•	•	•	•	•	•	•
T8700-E-D	Euro	Yes	•	•	•	•	•	•	•
T8700	US	No	•	•	•	•	•	•	•
T8700-D	US	Yes	•	•	•	•	•	•	•

Note: Custom branding is available on request (subject to quantity); contact your local GE Measurement & Control Solutions representative or distributor..

Unsurpassed Sensor Performance

Telaire T8700 utilizes a GE-made rugged capacitive sensor that provides full-scale 0-100% RH measurement with unsurpassed response times, linearity and stability. Recovery to condensation and chemicals is excellent and an integrated filter helps ensure long life. All sensors undergo intensive digital calibration, certified against a primary **NIST reference standard. NIST certificate is available at additional cost (part no. 3PTCERT).

Maximum Flexibility

Telaire T8700 is designed to be highly configurable in the field or in your warehouse. By minimizing the necessary number of configurations, GE reduces distributor inventory costs and provides maximum flexibility to the installer. All versions feature field-selectable outputs (0 to 5V, 0 to 10V, 4 to 20mA) and a passive and 10K Type II thermistor. Signal-conditioned temperature is scaled from 32°F to 122°F (0°C to 50°C) and Relative Humidity is scaled over 0-100%.

Rugged, Attractive Enclosures

All Telaire T8700 feature rugged flame retardant,

UL-94V ABS plastic. Special care has been taken in the design of the wall mount enclosure to provide enhanced airflow, increasing sensor response time and virtually eliminating the potential of "self-heating" by transmitter electronics that can lead to decreased accuracy measurements.

Simple, Fast Installation

All Telaire T8700 models feature a two piece enclosure with the back plate including terminal blocks eliminating the need to wire in a confined space and allow the unit to be pre-wired separate from the electronics. This is an especially attractive feature in unfinished construction, where exposed sensors and electronics could be damaged by moisture, drywall dust and paint.

Lowest Cost of Ownership

With a two-year warranty*, simplified inventory management, reduced installation times and field-serviceability, Telaire T8700 is a standard in reduced cost of ownership and performance-to-price ratio.

*Transmitter only, one year warranty on replaceable sensor.

*NIST/NPL certificate available on complete transmitter at extra cost.

Multi Measurement

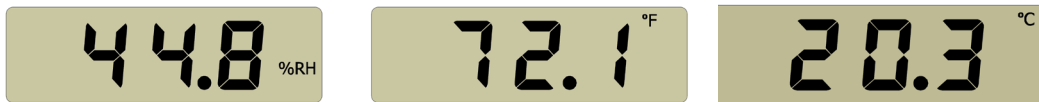

Display versions scroll between % Relative Humidity and Temperature (°C or °F)..



US sizes, both display and non-display..

European sizes (shows temperature in °C)

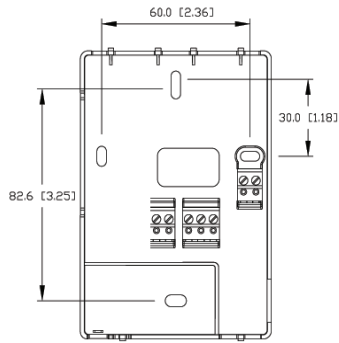
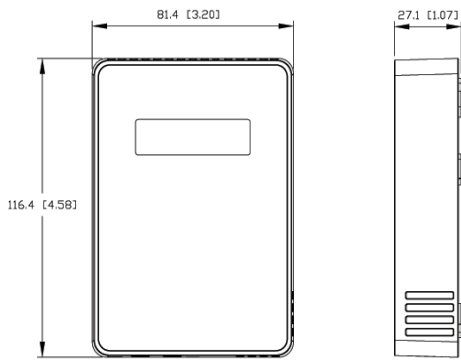

US wall mount dimensions

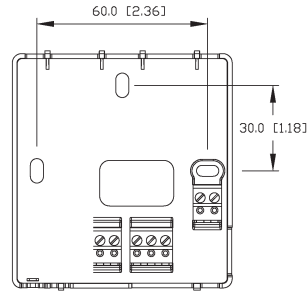
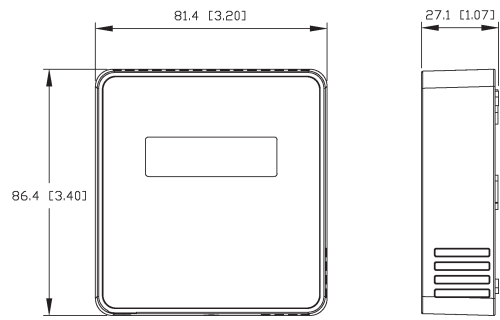

European wall mount dimensions

Wiring Features

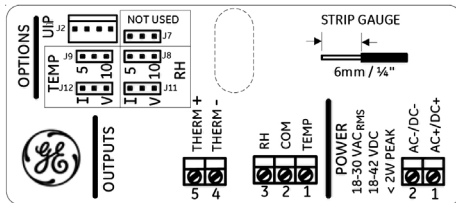

Telaire T8700 is fast and simple to install; the wiring diagram label shown is fixed to the inside of the back plate, making it easy to read and reducing the risk of miswiring. After wiring is complete, the front part of the enclosure, including the electronics, can be simply snapped on and held with a single safety screw.

Wall Mount Specifications

Sensing Method

Fully integrated humidity and temperature

Power Supply Requirements

18-30 VAC RMS, 50/60 Hz, or 18 to 42 VDC, polarity protected

Power Consumption

Typical 0.7 W at nominal voltage of 24V AC RMS

Temperature Dependence

0.2% FS per °C ($\pm 0.11\%$ per °F)

Warranty

Two years

Certifications

CE and RoHS compliant

Operating Conditions

- 32°F to 122°F (0°C to 50°C)
- 0 to 95% RH, non-condensing

Storage Conditions

-40°F to 158°F (-40°C to 70°C)

Flammability Classification

UL94 5VA

Thermistor Type

NTC 10 K Ω thermistor (passive)
datasheet available on request.

Thermistor Accuracy

$\pm 1^\circ\text{C}$ (15° to 35°C)

RH Sensing Element

Capacitive polymer sensor

RH Range

0% to 99% RH (non-condensing)

RH Accuracy (25°C)

$\pm 2.5\%$ RH (20 to 80% RH)
 $\pm 3.5\%$ RH (<20% and >80% RH)

Active Temperature Range

0 to 50°C

Active Temperature Accuracy

$\pm 0.8^\circ\text{C}$ @ 22°C

Output

Analog

- 0 to 10 V (100 Ω output impedance) and
- 4 to 20mA (R_L maximum 500 Ω) available simultaneously
- Digital to Analog Error $\pm 1\%$

Enhanced Field Serviceability

The T8700 series features a field-replaceable Relative Humidity (RH) sensor tip module that allows the end user to replace the sensor on-site while maintaining $\pm 2.5\%$ RH accuracy. The user simply powers off the unit, installs the new sensor module and powers back the unit. This virtually eliminates the need for time consuming and costly factory calibration, while reducing downtime during service intervals to near zero.



Replaceable, humidity sensor. Specially designed hydrophobic filter filter to prolong sensor calibration life.

