



99 Washington Street  
Melrose, MA 02176  
Phone 781-665-1400  
Toll Free 1-800-517-8431

# Defender<sup>®</sup> 5000

Standard Indicators

Visit us at [www.TestEquipmentDepot.com](http://www.TestEquipmentDepot.com)



## **Multifunctional Indicator for Standard Industrial Applications**

The OHAUS next generation Defender 5000 Series multifunctional indicator is ideal for use in conjunction with bench and floor scales for a multitude of applications including production, packaging, inventory, and shipping. Built durably and equipped with advanced features such as maximum configurability print output, GMP/GLP data output, library/user management, and multiple connectivity options - the Defender 5000 Series is designed to handle demanding industrial and commercial applications.

### **Standard Features:**

- **Indicator Guides The User with On-Screen Prompts**  
See results clearly on the large backlit display. The alphanumeric keypad and function keys allow for a simplified user experience. On-screen prompts and soft keys will guide you through the operation.
- **Multiple Connectivity Options for Convenient Data Transfer and Storage**  
Results can be stored in the included Micro SD card. Data output via built-in RS232 or optional interfaces including 2nd RS232/RS485/USB device, Ethernet, Bluetooth/WiFi, Analog Output and Discrete I/O with relays.
- **Multiple Application Modes and High Storage Capacity for Greater Flexibility**  
Features common industrial modes and supports a 50,000 item library and 1,000 user profiles which can be downloaded/uploaded for easy set-up with the included Micro SD Card. Also equipped with GMP/GLP capability with time/date for result traceability.
- **Install Easily with the EasyConnect Feature**  
When connecting to the new Defender 5000 bases, the EasyConnect™ technology allows instant connection and use of the scale without extra configuration.

# Ingeniously Practical

# Defender<sup>®</sup> 5000 Standard Indicators

## Simplified Use

Results can be read easily on the Defender 5000's large transfective dot matrix display, even in bright sunlight. The SmartText 3.0 interface will guide you through all of the Defender 5000's unique and advanced features. With five soft keys, SmartText 3.0 makes an advanced scale very simple to use, and reduces training time for operators.



## Multiple Connectivity Options

Weighing results can be easily exported through the standard RS232 port and Micro-SD slot. Additional connectivity options include a second RS232, RS485 or USB device; Ethernet and WiFi/Bluetooth interfaces.

Using the Analog Option (either 4-20mA or 0-10V) or two In/four Out Discrete I/O, the new Defender 5000 indicator can also be used for PLC systems.



## Simple Operation

Featuring most common applications including Parts Counting with APW optimization, Checkweighing or Checkcounting, Percent Weighing, and Dynamic Weighing or Display Hold, the Defender 5000 meets the weighing and measurement needs of practically every industrial application or manufacturing process. Many application modes eliminate the need for long and complicated manual calculations. GMP/GLP with time/date allows for traceability of results.

Equipped with the included Micro SD card, the Defender 5000 can support storage of up to 50,000 items and 1,000 user profiles. Weighing results can also be stored in Alibi or regular format, addressing all your data storage needs.



## Easy Installation

The latest technology EasyConnect<sup>™</sup>, allows the Defender 5000 indicator and base to be freely connected without needing extra configuration. Plug and play - save your time and money for installation and adjustment.



# Defender<sup>®</sup> 5000 Standard Indicators

## Indicator Specifications

	TD52P	TD52XW
Construction	ABS plastic, powder-coated steel bracket	304 stainless steel with sand blasted surface treatment, stainless steel bracket
Protection	N/A	IP68 / NEMA 4X
A/D Conversion Rate	80 Hz	
Capacity Selections	999,999 with decimal located to five places	
Maximum Display Resolution	1:75,000	
Certified Accuracy Class (Nmax)	10,000 Measurement Canada: III, IIIHD; NTEP: III, IIII	
Weighing Units	Kilogram, Gram, Pound, Ounce, Pound: Ounce, Tonne (Metric Tonne), Ton (Short Ton), Custom unit	
Application Modes	Weighing, Percent Weighing, Piece Counting with Optimized APW, Checkweighing/Checkcounting, Dynamic Weighing/Display Hold	
Display	Dot matrix LCD with white LED backlight, 256 x 80 pixels	
Keyboard	6 function, 5 soft keys, 12 alpha numeric membrane switches	
Auto-zero Tracking	Off, 0.5 d, 1 d or 3 d	
Zeroing Range	2% or 100% of capacity	
Calibration	Zero, Span or 3-point Linear	
Span Calibration	1 kg or 1 lb to capacity	
Internal Resolution	1,137,000 counts per mV/V	
Digital Filtering/Type	Averaging	
Load Cell Excitation Voltage	5VDC	
Load Cell Drive	Up to 8 x 350 ohm load cells	
Load Cell Input Sensitivity	Up to 3 mV/V	
Stabilization Time	Within 2 seconds	
Power	100-240 VAC / 50/60 Hz Universal Power Supply, Rechargeable Lithium battery (optional)	
Battery Life	20 hours of continuous use	
Interface	Standard RS232, MicroSD Card (included) Optional Ethernet, WiFi/Bluetooth, 2 <sup>nd</sup> RS232/RS485/USB, Analog Output, 2 In/4 Out Digital I/O	
Shipping Dimensions	11.8 x 10.4 x 5.3 in 300 x 265 x 135 mm	
Approx. Net Weight	3.3 lb / 1.5 kg	4.4 lb / 2 kg
Approx. Shipping Weight	4.4 lb / 2 kg	5.5 lb / 2.5 kg
Operating Temperature Range	14°F to 104°F / -10°C to 40°C	

TD52P

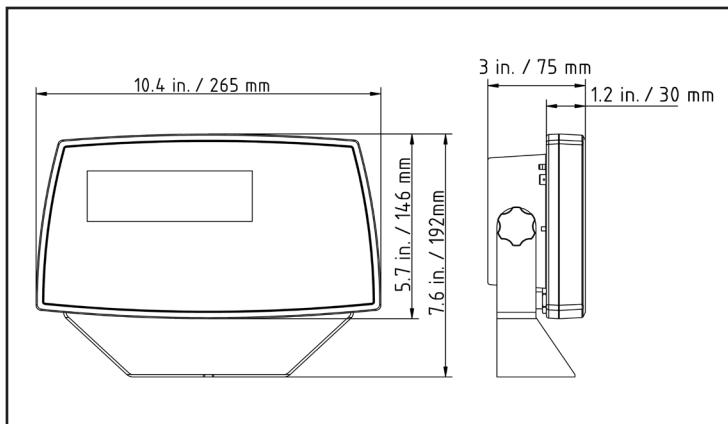

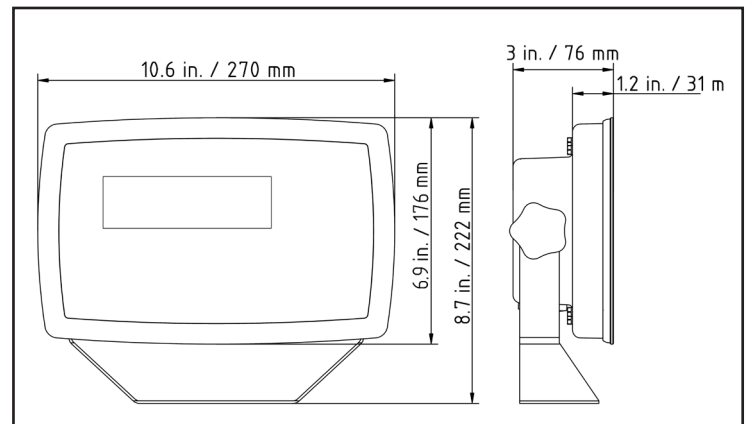

TD52XW





# Defender<sup>®</sup> 5000 Standard Indicators

## Application Modes

- 

**Weighing:** Determine the weight of items in the selected unit of measure.
- 

**Percent Weighing:** Measure the weight of a sample displayed as a percentage of a pre-established reference weight.
- 

**Parts Counting:** Count samples of uniform weight. Advanced auto-optimization software recalculates the average piece of weight as the overall weight increases.
- 

**Dynamic Weighing and Display Hold:** Weigh an unstable load. Scale takes an average of weights over a period of time. The Display Hold feature manually or automatically holds the last stable weight on the display.
- 

**Checkweighing/Counting:** Compare the weight/count of a sample against target limits. Connect with Discrete I/O and Light Tower Kit for external check lights.

## Other Standard Features and Equipment

Checkweighing symbols with selectable operation and audible signal settings, menu lock switch, multiple operating languages, selectable environmental and auto-print settings, stability indicator, overload/underload indicators, selectable adjust contrast settings, auto-dim, auto-off, auto tare, screensaver.

## Compliance

- **Metrology:** Measurement Canada Class III, IIIHD (NoA AM-6093); NTEP Class III, IIIL (CC 18-065)
- **Product Safety:** CAN/CSA C22.2 61010-1; UL61010-1; IEC/EN 61010-1
- **Electromagnetic Compatibility:** FCC Part 15 Class B; Canada ICES-003 Class B; IEC/EN 61326-1 Class B, basic environments
- **Food Equipment:** ANSI/NSF 169 (TD52XW only)
- **Compliance Marks:** CE; CSA; NSF (TD52XW only)

## Accessories

WiFi/BT Dongle, OHAUS (Requires 30424406) <sup>2</sup> . . . . .	30412537
Analog Output Kit, TD52 <sup>3</sup> . . . . .	30424403
2nd RS232/RS485/USB, TD52 <sup>3</sup> . . . . .	30424404
Battery Kit, Li-ion, TD52 . . . . .	30424405
USB Host for Dongle, TD52 . . . . .	30424406
Light Tower, 3 Colors, 243mm, IP65 (Requires 30097591) . . . . .	30424021
In-use Cover Set, TD52P . . . . .	30424022
In-use Cover Set, TD52XW . . . . .	30424023
In-use Cover set (10), TD52P . . . . .	30469948
In-use Cover set (10), TD52XW . . . . .	30469949
Wall Mount Kit, SST, TD52XW . . . . .	30424026
Wall Mount Kit, CS, TD52P . . . . .	30424027
LC Extension Cable, 9 meters, D52 <sup>1</sup> . . . . .	30424409
M16 Gland with Ferrite, to TD52 . . . . .	30379716
Micro SD Card, 8G . . . . .	30303533
I/O with Relay (2 In/4 Out) <sup>3</sup> . . . . .	30097591
Ethernet Kit, D52 <sup>2</sup> . . . . .	30429666
Impact Printer SF40A . . . . .	30064203
Thermal Printer STP-103 . . . . .	80251992

<sup>1</sup> Cannot be used for legal-for-trade applications    <sup>2</sup> Only one of them can be used at the same time    <sup>3</sup> Only one of them can be used at the same time



99 Washington Street  
Melrose, MA 02176  
Phone 781-665-1400  
Toll Free 1-800-517-8431

[Visit us at www.TestEquipmentDepot.com](http://www.TestEquipmentDepot.com)

80775451 20181113 © Copyright OHAUS Corporation

The management system governing the manufacture of this product is ISO 9001:2015 certified.

