

Keysight U2741A USB Modular 5.5 Digits Digital Multimeter

Notices

Copyright Notice

© Keysight Technologies 2008 - 2017
No part of this manual may be reproduced in any form or by any means (including electronic storage and retrieval or translation into a foreign language) without prior agreement and written consent from Keysight Technologies as governed by United States and international copyright laws.

Manual Part Number

U2741-90001

Edition

Edition 10, March 17, 2017

Printed in:

Printed in Malaysia

Published by:

Keysight Technologies
Bayan Lepas Free Industrial Zone,
11900 Penang, Malaysia

Technology Licenses

The hardware and/or software described in this document are furnished under a license and may be used or copied only in accordance with the terms of such license.

Declaration of Conformity

Declarations of Conformity for this product and for other Keysight products may be downloaded from the Web.

U.S. Government Rights

The Software is “commercial computer software,” as defined by Federal Acquisition Regulation (“FAR”) 2.101. Pursuant to FAR 12.212 and 27.405-3 and Department of Defense FAR Supplement (“DFARS”) 227.7202, the U.S. government acquires commercial computer software under the same terms by which the software is customarily provided to the public. Accordingly, Keysight provides the Software to U.S. government customers under its standard commercial license, which is embodied in its End User License Agreement (EULA). The license set forth in the EULA represents the exclusive authority by which the U.S. government may use, modify, distribute, or disclose the Software. The EULA and the license set forth therein, does not require or permit, among other things, that Keysight: (1) Furnish technical

information related to commercial computer software or commercial computer software documentation that is not customarily provided to the public; or (2) Relinquish to, or otherwise provide, the government rights in excess of these rights customarily provided to the public to use, modify, reproduce, release, perform, display, or disclose commercial computer software or commercial computer software documentation. No additional government requirements beyond those set forth in the EULA shall apply, except to the extent that those terms, rights, or licenses are explicitly required from all providers of commercial computer software pursuant to the FAR and the DFARS and are set forth specifically in writing elsewhere in the EULA. Keysight shall be under no obligation to update, revise or otherwise modify the Software. With respect to any technical data as defined by FAR 2.101, pursuant to FAR 12.211 and 27.404.2 and DFARS 227.7102, the U.S. government acquires no greater than Limited Rights as defined in FAR 27.401 or DFAR 227.7103-5 (c), as applicable in any technical data.

Warranty

THE MATERIAL CONTAINED IN THIS DOCUMENT IS PROVIDED “AS IS,” AND IS SUBJECT TO BEING CHANGED, WITHOUT NOTICE, IN FUTURE EDITIONS. FURTHER, TO THE MAXIMUM EXTENT PERMITTED BY APPLICABLE LAW, KEYSIGHT DISCLAIMS ALL WARRANTIES, EITHER EXPRESS OR IMPLIED, WITH REGARD TO THIS MANUAL AND ANY INFORMATION CONTAINED HEREIN, INCLUDING BUT NOT LIMITED TO THE IMPLIED WARRANTIES OF MERCHANTABILITY AND FITNESS FOR A PARTICULAR PURPOSE. KEYSIGHT SHALL NOT BE LIABLE FOR ERRORS OR FOR INCIDENTAL OR CONSEQUENTIAL DAMAGES IN CONNECTION WITH THE FURNISHING, USE, OR PERFORMANCE OF THIS DOCUMENT OR OF ANY INFORMATION CONTAINED HEREIN. SHOULD KEYSIGHT AND THE USER HAVE A SEPARATE WRITTEN AGREEMENT WITH WARRANTY TERMS COVERING THE MATERIAL IN THIS DOCUMENT THAT CONFLICT WITH THESE TERMS, THE WARRANTY TERMS IN THE SEPARATE AGREEMENT SHALL CONTROL.

Safety Information

CAUTION

















A CAUTION notice denotes a hazard. It calls attention to an operating procedure, practice, or the like that, if not correctly performed or adhered to, could result in damage to the product or loss of important data. Do not proceed beyond a CAUTION notice until the indicated conditions are fully understood and met.

WARNING

A WARNING notice denotes a hazard. It calls attention to an operating procedure, practice, or the like that, if not correctly performed or adhered to, could result in personal injury or death. Do not proceed beyond a WARNING notice until the indicated conditions are fully understood and met.

Safety Symbols

The following symbols on the instrument and in the documentation indicate precautions which must be taken to maintain safe operation of the instrument.

	Direct current (DC)		Off (mains supply)
	Alternating current (AC)		On (mains supply)
	Both direct and alternating current		Caution, risk of electric shock
	Three-phase alternating current		Caution, risk of danger (refer to this manual for specific Warning or Caution information)
	Earth (ground) terminal		Caution, hot surface
	Protective earth (ground) terminal		Out position of a bi-stable push control
	Frame or chassis (ground) terminal		In position of a bi-stable push control
	Equipotentiality	CAT II 300 V	Category II 300 V overvoltage protection
	Equipment protected throughout by double insulation or reinforced insulation		

General Safety Information

WARNING

- Do not use the device if it is damaged. Before you use the device, inspect the casing. Look for cracks or missing plastic. Do not operate the device around explosive gas, vapor, or dust.
 - Always use the device with the cables provided.
 - Observe all markings on the device before establishing any connection.
 - Turn off the device and application system power before connecting to the I/O terminals.
 - When servicing the device, use only the specified replacement parts.
 - Do not operate the device with the cover removed or loosened.
 - Use only the power adapter provided by the manufacturer to avoid any unexpected hazards.
-

CAUTION

- If the device is used in a manner not specified by the manufacturer, the device protection may be impaired.
 - Always use dry cloth to clean the device. Do not use ethyl alcohol or any other volatile liquid to clean the device.
 - Do not permit any blockage of the ventilation holes of the device.
-

Environmental Conditions

This instrument is designed for indoor use and in an area with low condensation. The table below shows the general environmental requirements for this instrument.





Environmental condition	Requirement
Operating temperature	0 °C to 50 °C
Operating humidity	20% to 85% RH non-condensing
Storage temperature	-20 °C to 70 °C
Storage humidity	5% to 90% RH non-condensing

CAUTION

The U2741A USB modular digital multimeter complies with the following safety and EMC requirements.

- IEC 61010-1:2001/EN61010-1:2001 (2nd Edition)
- Canada: CAN/CSA-C22.2 No. 61010-1-04
- USA: ANSI/UL 61010-1:2004
- IEC 61326-2002/EN 61326:1997+A1:1998+A2:2001+A3:2003
- Canada: ICES-001:2004
- Australia/New Zealand: AS/NZS CISPR11:2004

Regulatory Markings

 <p>The CE mark is a registered trademark of the European Community. This CE mark shows that the product complies with all the relevant European Legal Directives.</p>	 <p>The RCM mark is a registered trademark of the Spectrum Management Agency of Australia. This signifies compliance with the Australia EMC Framework regulations under the terms of the Radio Communication Act of 1992.</p>
<p>ICES/NMB-001</p> <p>ICES/NMB-001 indicates that this ISM device complies with the Canadian ICES-001. Cet appareil ISM est conforme a la norme NMB-001 du Canada.</p>	 <p>This instrument complies with the WEEE Directive (2002/96/EC) marking requirement. This affixed product label indicates that you must not discard this electrical or electronic product in domestic household waste.</p>
 <p>The CSA mark is a registered trademark of the Canadian Standards Association.</p>	

Waste Electrical and Electronic Equipment (WEEE) Directive 2002/96/EC

This instrument complies with the WEEE Directive (2002/96/EC) marking requirement. This affixed product label indicates that you must not discard this electrical or electronic product in domestic household waste.

Product category:

With reference to the equipment types in the WEEE directive Annex 1, this instrument is classified as a “Monitoring and Control Instrument” product.

The affixed product label is as shown below.



Do not dispose in domestic household waste.

THIS PAGE HAS BEEN INTENTIONALLY LEFT BLANK.

Table of Contents

Safety Symbols	3
General Safety Information	4
Environmental Conditions	5
Regulatory Markings	6
Waste Electrical and Electronic Equipment (WEEE) Directive	
2002/96/EC	7
Product category:	7
Sales and Technical Support	7
1 Getting Started	
Introduction	16
Product at a Glance	17
Product outlook	17
Product Dimensions	19
Dimensions without bumpers	19
Dimensions with bumpers	20
Standard Shipped Items	21
Inspection and Maintenance	22
Initial inspection	22
Electrical check	22
General maintenance	23
Installation and Configuration	24
Instrument Configuration	25
55-Pin backplane connector pin configuration	25
Chassis installation	26
2 Operation and Features	
Powering Up	28
Making Measurements	29
Measuring DC voltage	29

Measuring AC voltage	31
Measuring DC current	32
Measuring AC current	33
Measuring resistance	34
Measuring frequency	36
Testing continuity	37
Testing diodes	38
Measuring temperature	39
Restoring Instrument State	40
Autozero	40
Ranging	41
Default Settings	42
Triggering the U2741A	43
System-Related Operation	45
Error conditions	45
3 Measurement Tutorial	
DC Measurement Considerations	48
Noise Rejection	49
Resistance Measurement Considerations	52
AC Measurements	55
Other Primary Measurement Functions	57
Frequency measurement errors	57
DC current measurements	57
Other Sources of Measurement Error	59
4 Characteristics and Specifications	

List of Figures

Figure 1-1	55-pin backplane connector pin configuration	25
Figure 3-1	Common mode source error	49
Figure 3-2	Ground loop induced error	51
Figure 3-3	Burden voltage in current measurement	58

THIS PAGE HAS BEEN INTENTIONALLY LEFT BLANK.

List of Tables

Table 1-1	SSI connector pin description	25
Table 2-1	Default settings summary	42
Table 3-1	Thermoelectric voltage for dissimilar metals connections	48
Table 3-2	Power dissipation for various resistance ranges	54
Table 3-3	Waveform shapes and their parameters	55

THIS PAGE HAS BEEN INTENTIONALLY LEFT BLANK.

1 Getting Started

Introduction	16
Product at a Glance	17
Product Dimensions	19
Standard Shipped Items	21
Inspection and Maintenance	22
Installation and Configuration	24
Instrument Configuration	25

Introduction

The Keysight U2741A is a 5.5 digits digital multimeter that can operate as standalone or as a modular unit when used with the U2781A USB modular instrument chassis.

U2741A can perform the following measurements:

- DC Voltage
- AC Voltage
- DC Current
- AC Current
- Resistance
- Diode Test
- Continuity Test
- Temperature
- Frequency

The U2741A is controlled remotely over a USB interface via the Keysight Measurement Manager (KMM) software. The U2741A can also be programmed using the provided drivers or via SCPI commands in your customized application.

Product at a Glance

Product outlook

Top view

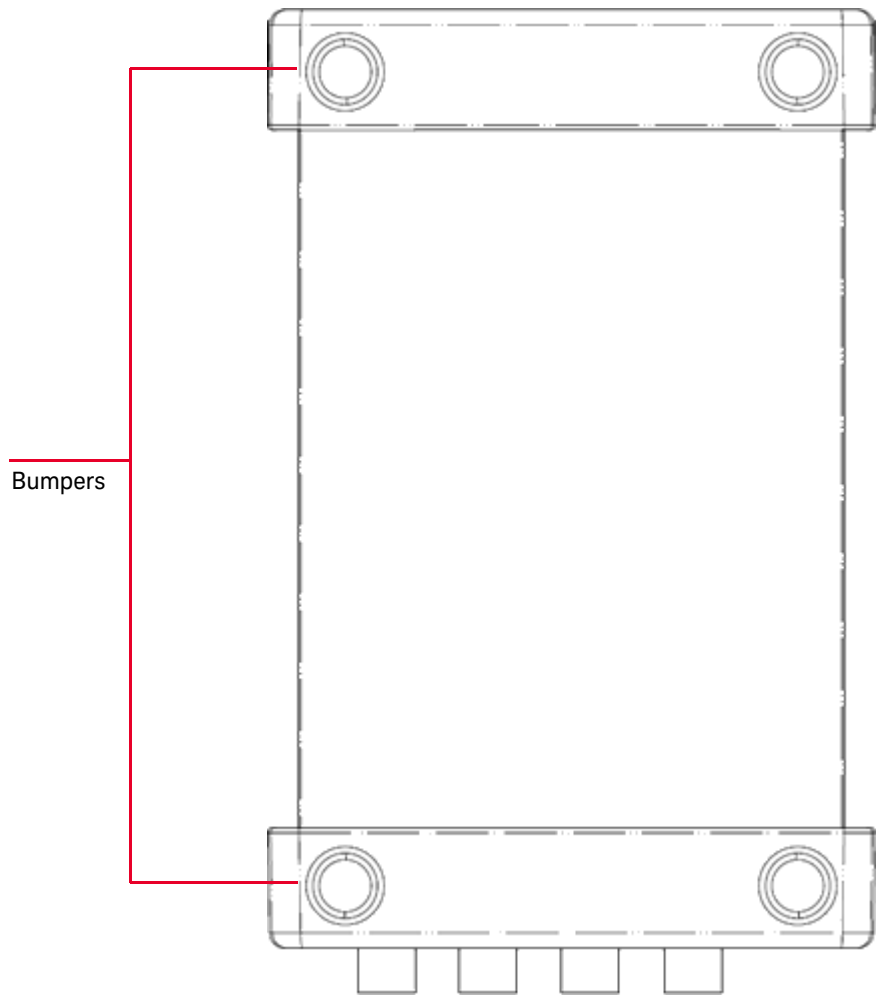

Front view

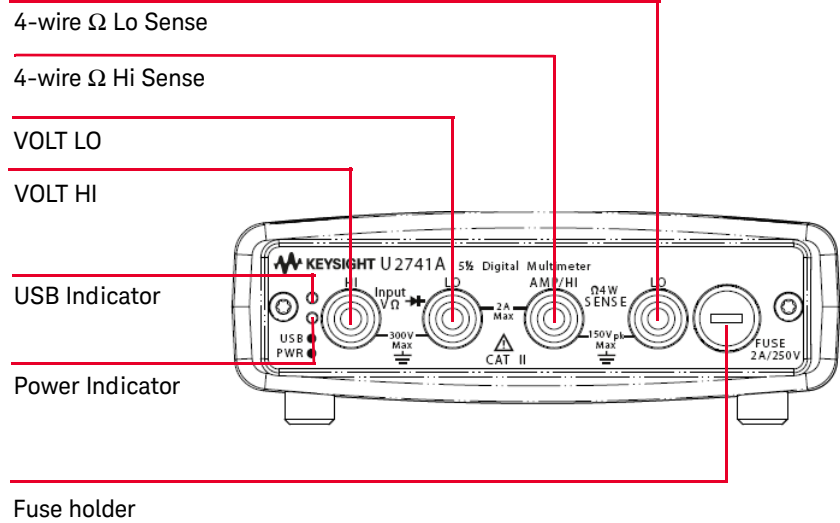

Rear view

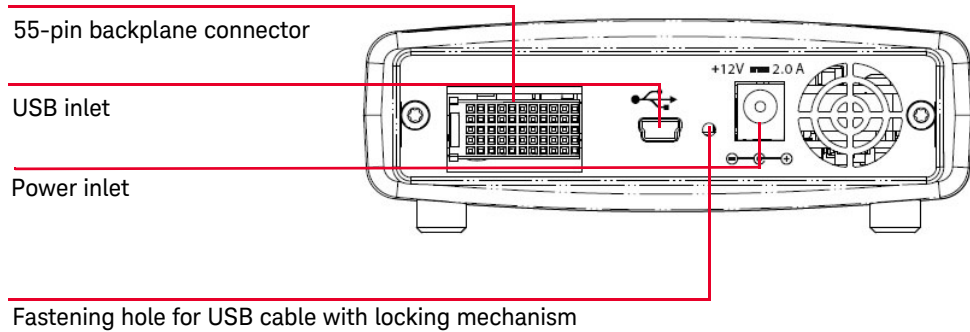

Product Dimensions

Dimensions without bumpers

Top view

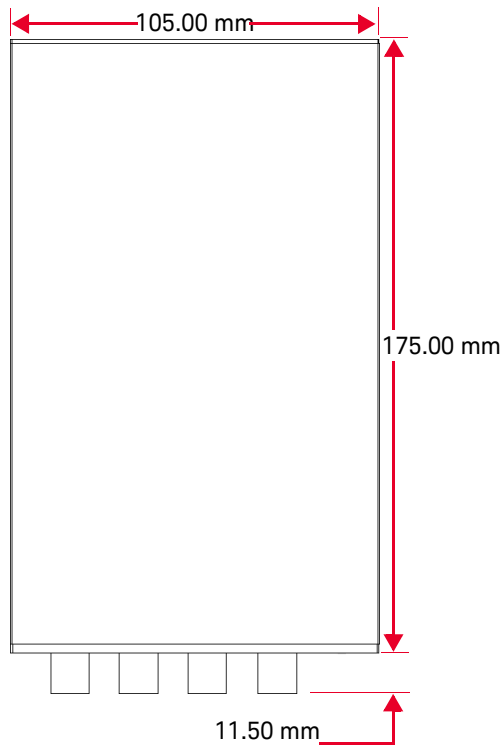

Front view

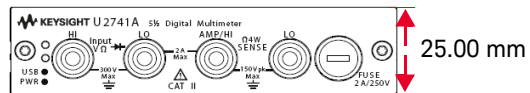

1 Getting Started

Dimensions with bumpers

Top view

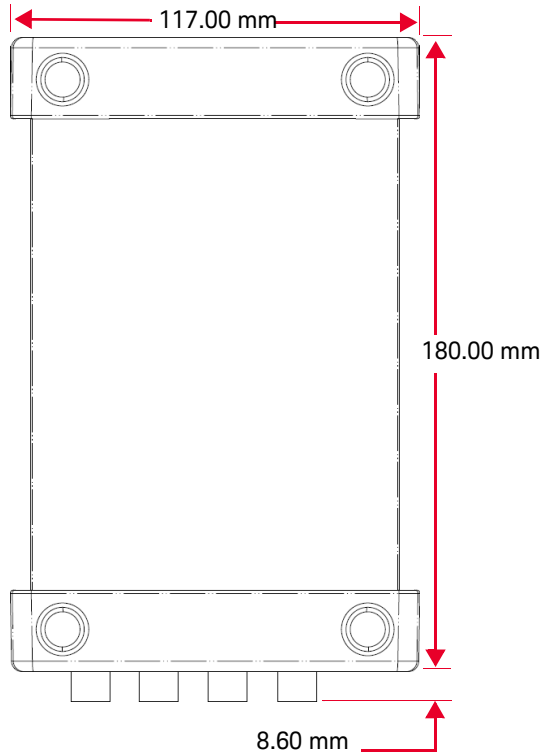

Front view

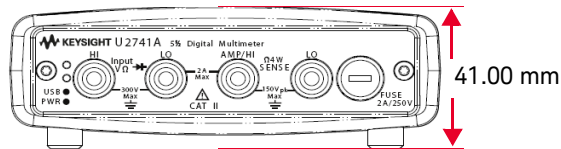

Standard Shipped Items

Verify that you have received the following items with your unit. If anything is missing or damaged, please contact the nearest Keysight Sales Office.

- ✓ 12 V, 2 A AC/DC adapter
- ✓ Power cord
- ✓ Standard Test Lead
- ✓ USB Standard-A to Mini-B interface cable
- ✓ L-Mount kit (used with the modular instrument chassis)
- ✓ Keysight Automation-Ready CD-ROM (contains the Keysight IO Libraries Suite)
- ✓ Keysight USB Modular Products and Systems Quick Start Guide
- ✓ Keysight USB Modular Products and Systems Product Reference DVD-ROM
- ✓ Keysight Measurement Manager Quick Reference Card
- ✓ Certificate of Calibration

Inspection and Maintenance

Initial inspection

When you receive your U2741A, inspect the unit for any obvious damage such as broken terminals or cracks, dents, and scratches on the casing that may occur during shipment.

If any damage is found, notify the nearest Keysight Sales Office immediately. The front of this manual contains the warranty information.

Keep the original packaging in case the U2741A has to be returned to Keysight in the future. If you return the U2741A for service, attach a tag identifying the owner and model number. Also include a brief description of the problem.

Electrical check

For verification procedures, refer to *Keysight U2741A USB Modular 5.5 Digits Digital Multimeter Service Guide*. The procedures will verify to a high level of confidence that the U2741A is operating in accordance to its specifications.

General maintenance

General maintenance

NOTE

Any repair that is not covered in your modular product manuals should only be performed by qualified personnel.

- 1 Power off your module and remove the power cord and I/O cable from your device.
- 2 Remove your module from the bumper casing.
- 3 Shake out any dirt that may have accumulated on the module.
- 4 Wipe your module with a dry cloth and install the bumper back in place.

Installation and Configuration

Follow the step-by-step instructions shown in the *Keysight USB Modular Products and Systems Quick Start Guide* to get started with the preparations and installations of your U2741A.

NOTE

You need to install the IVI-COM driver if you are going to use the U2741A with Keysight VEE Pro, LabVIEW, or Microsoft® Visual Studio®.

Instrument Configuration

55-Pin backplane connector pin configuration

The 55-pin backplane connector is used when the U2741A module is inserted into the U2781A USB modular instrument chassis. For more details, refer to the *Keysight U2781A USB Modular Instrument Chassis User's Guide*.

GND	GND	GND	GND	GND	GND	GND	GND	GND	GND	GND	F
NC	NC	NC	NC	NC	NC	NC	NC	VBUS	GND	USB_D-	E
GND	TRIG3	GND	TRIG2	ND	TRIG1	GND	TRIG0	GND	GND	USB_D+	D
TRIG4	GND	TRIG5	GND	TRIG6	GND	TRIG7	GND	+12 V	+12 V	GND	C
nBPUB	CLK10M	GND	STAR_TRIG	GA2	GA1	GA0	NC	+12 V	+12 V	+12 V	B
NC	NC	NC	NC	NC	NC	NC	NC	+12 V	+12 V	+12 V	A
11	10	9	8	7	6	5	4	3	2	1	

Figure 1-1 55-pin backplane connector pin configuration

Table 1-1 SSI connector pin description

SSI timing signal	Functionality
GND	Ground
NC	Not connected
VBUS	USB bus power sensing input
USB_D+, USB_D-	USB differential pair
TRIG0~TRIG7	Trigger bus
+12 V	+12 V power with 4 A current
nBPUB	USB backplane input detect

Table 1-1 SSI connector pin description (continued)

SSI timing signal	Functionality
CLK10M	10 MHz clock source
STAR_TRIG	Star trigger
GA0,GA1,GA2	Geographical address pin

Chassis installation

The L-Mount kit is to be installed to your U2741A module.

The following instructions describe the simple procedure of installing the L-Mount kit and your module in the chassis.

- 1** Unpack the L-Mount kit from the packaging.
- 2** Remove your U2741A module from the bumper casing.
- 3** Use a Phillips screwdriver to fasten the L-Mount kit to your U2741A module.
- 4** Insert your U2741A module into the U2781A chassis with the 55-pin backplane connector positioned at the bottom of the module.
- 5** Once you have slotted in the module, tighten the screws of the L-Mount kit to secure the connection.

2 Operation and Features

Powering Up	28
Making Measurements	29
Restoring Instrument State	40
Default Settings	42
Triggering the U2741A	43
System-Related Operation	45

This chapter contains the details on how to configure your U2741A USB modular digital multimeter to perform the various measurement functions either through the software front panel or by sending SCPI commands remotely via the USB interface.

Powering Up

Take note of the following when you power up the U2741A.

- The U2741A can only be operated via the USB interface.
- Before you can control the U2741A, you need to install the hardware driver and the IO Libraries Suite 14.2 or higher. Both of these are included when you purchase the U2741A. Refer to the *Keysight USB Modular Products and Systems Quick Start Guide* for the installation procedure.
- On the front panel of the U2741A, there are two LED indicators. Refer to [Chapter 1, “Product outlook”](#) on page 17.
- Power indicator lights up once the U2741A is powered up. It will blink if there is a system error.
- USB indicator will only blink when there is data exchange activity between the U2741A and the PC.

You can control your U2741A via the KMM for U2741A or via SCPI commands sent through the USB interface from your own application programs.

The Keysight U2741A complies with the syntax rules and conventions of SCPI commands.

You can determine the U2741A's SCPI language version by sending the **SYSTem:VERSion?** command from the remote interface.

For a complete discussion of U2741A's SCPI syntax, refer to the *Keysight U2741A Programmer's Reference*.

Making Measurements

The following pages show how to make measurement connections and how to select measurement functions from the front panel for each of the measurement functions.

Measuring DC voltage

The DC voltage measurement function has the following features:

- Five ranges to select: 100 mV, 1 V, 10 V, 100 V, and 300 V, or auto-range.
- Input impedance is 10 M Ω for all ranges (typical).
- Input protection is 300 V on all ranges (HI terminal).

Make the connection as shown below.

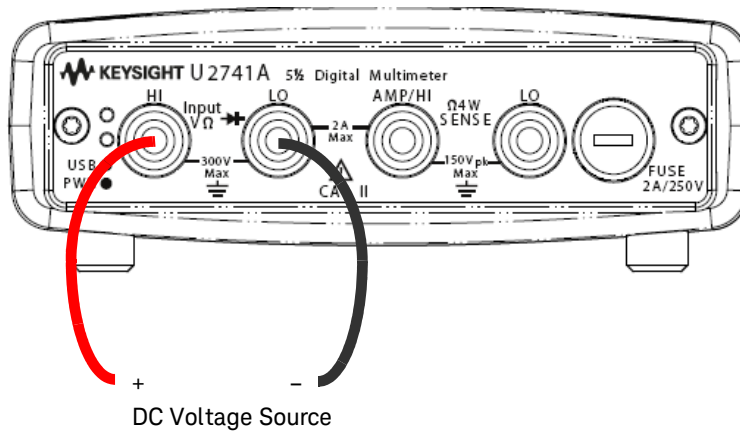

Keysight Measurement Manager operation

Select the **DCV** function and desired range. A suitable range should be selected to give the best measurement resolution. The reading is displayed and updated continuously.

SCPI commands

The following example shows how to make a DC voltage measurement using SCPI commands.

```
MEASure[:VOLTage]:DC?
```

Measuring AC voltage

The AC voltage measurement function has the following features:

- Five ranges to select: 100 mVrms, 1 Vrms, 10 Vrms, 100 Vrms, and 250 Vrms, or auto-range.
- Measures the AC-coupled true RMS.
- Measures within the stipulated accuracy at a crest factor of a maximum of 5:1 (full scale).
- Input impedance is $1\text{ M}\Omega \pm 2\%$ in parallel with less than 120 pF capacitance on all ranges.

Make the connection as shown below.

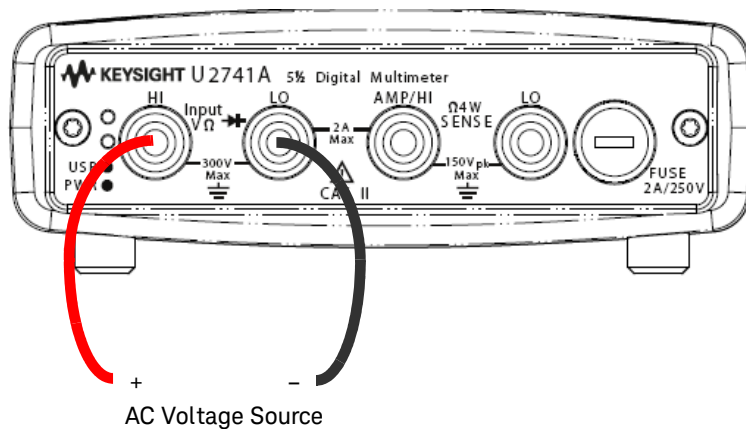

Keysight Measurement Manager operation

Select the **ACV** function and desired range. A suitable range should be selected to give the best measurement resolution. The reading is displayed and updated continuously.

SCPI commands

The following example shows how to make an AC voltage measurement using SCPI commands.

```
MEASure[:VOLTage]:AC?
```

Measuring DC current

The DC current measurement function has the following features:

- Three ranges to select: 10 mA, 100 mA, 1 A and 2 A, or auto-range.
- Input protection fuse is 2 A, voltage rating 250 V on all ranges.

Make the connection as shown below.

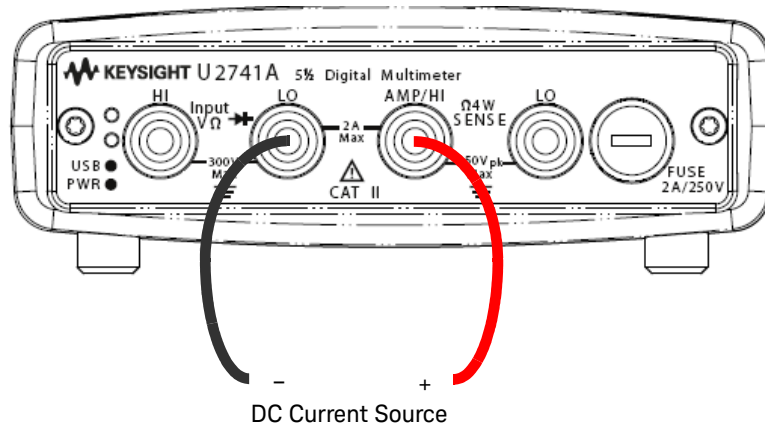

Keysight Measurement Manager operation

Select the **DCI** function and desired range. A suitable range should be selected to give the best measurement resolution. The reading is displayed and updated continuously.

SCPI commands

The following example shows how to make a DC current measurement using SCPI commands.

```
MEASure:CURREnt[:DC]?
```

Measuring AC current

The AC current measurement function has the following features:

- Three ranges to select: 10 mA, 100 mA, 1 A and 2 A or, auto-range.
- Measures true rms value.

Make the connection as shown below.

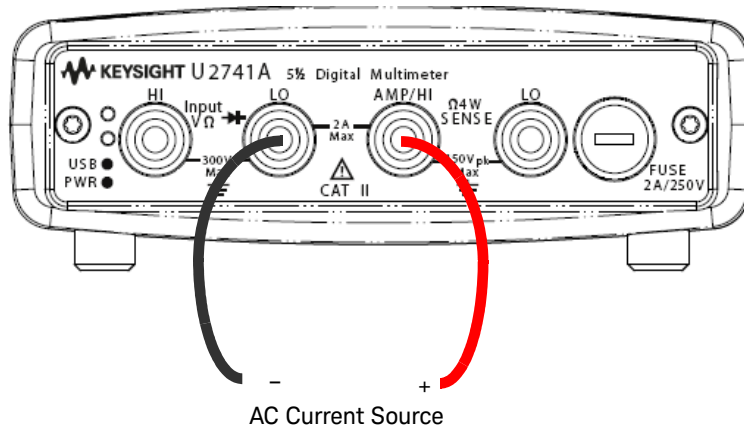

Keysight Measurement Manager operation

Select the **ACI** function and desired range. A suitable range should be selected to give the best measurement resolution. The reading is displayed and updated continuously.

SCPI commands

The following example shows how to make an AC current measurement using SCPI commands.

```
MEASure:CURRent:AC?
```

Measuring resistance

The resistance measurement function has the following features:

- Seven ranges to select: 100 Ω , 1 k Ω , 10 k Ω , 100 k Ω , 1 M Ω , 10 M Ω , and 100 M Ω or, auto-range.
- Supports two-wire and four-wire resistance measurement.
- Open circuit voltage is limited to less than 4.5 V on all ranges.

The figure below shows a two-wire resistance measurement connection.

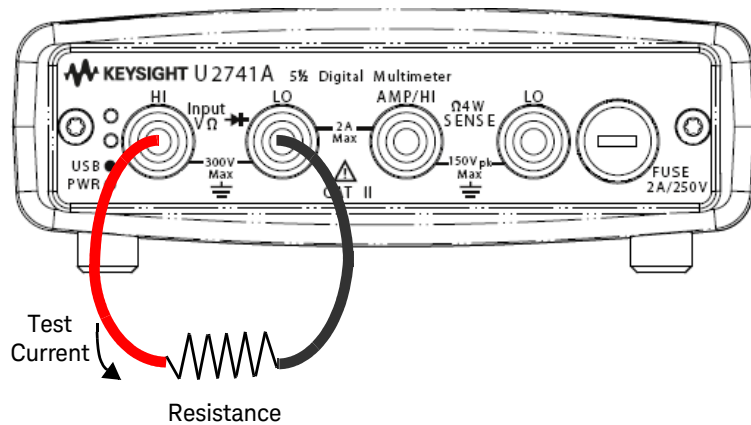

The following figure shows a four-wire resistance measurement connection.

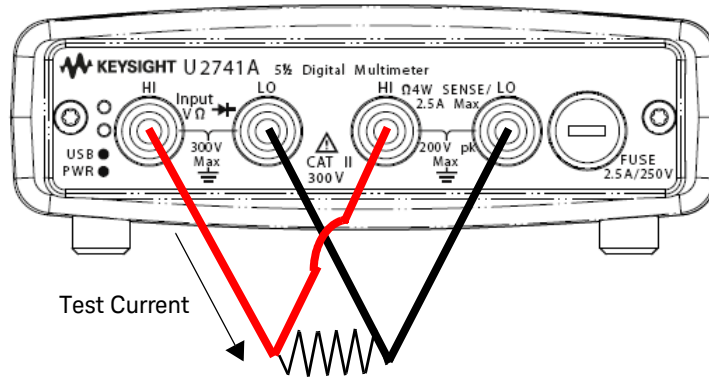

Keysight Measurement Manager operation

Select the **2-Wired Ω** function and desired range for two-wire resistance measurement. Select the **4-Wired Ω** function and desired range for four-wire resistance measurement. A suitable range should be selected to give the best measurement resolution. The reading is displayed and updated continuously.

SCPI commands

The following example shows how to make a resistance measurement using SCPI commands.

Two-wire: `MEASure:RESistance?`

Four-wire: `MEASure:FRESistance?`

Measuring frequency

The frequency measurement function has the following features:

- Range is based on the amplitude of the signal.
- Employs a reciprocal counting technique as the measurement method.
- Gate time can be set at 0.1 second or 1 second of the input signal.

Make the connection as shown below.

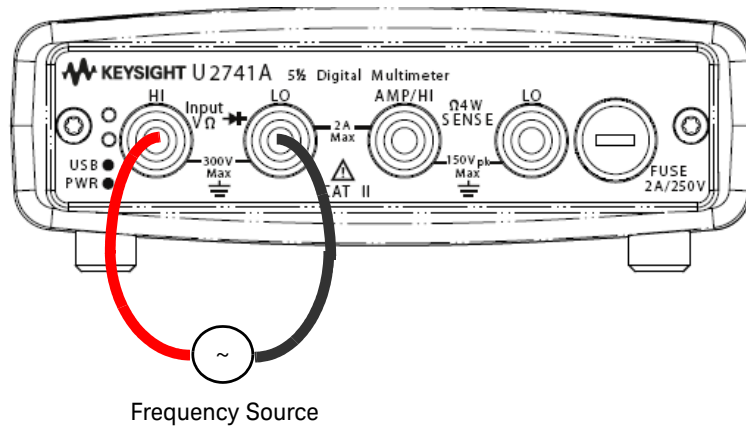

Keysight Measurement Manager operation

Select the **Freq** function and desired range. The reading is displayed and updated continuously.

SCPI commands

The following example shows how to make a frequency measurement using SCPI commands.

```
MEASure:FREQuency?
```

Testing continuity

The continuity testing function has the following features:

- Uses a $1\text{ mA} \pm 0.2\%$ constant current source.
- Open circuit voltage is limited to less than 4.5 V for all ranges.
- Continuity threshold is fixed at $10\ \Omega$.
- Response time is 60 samples/second.

Make the connection as shown below.

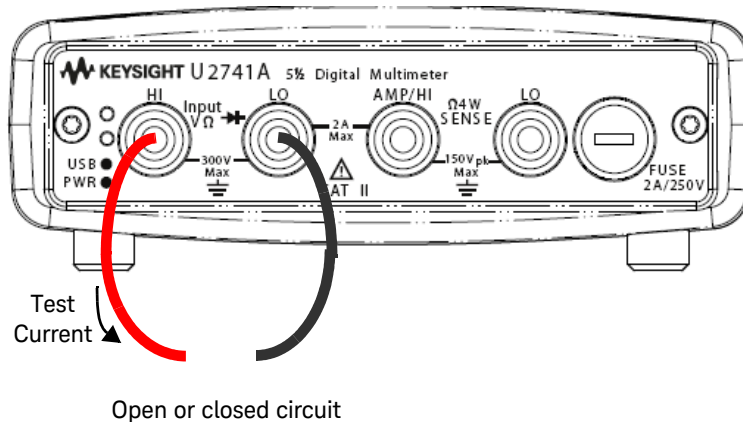

Keysight Measurement Manager operation

Select the **Cont-))** function. The reading is displayed and updated continuously.

SCPI commands

The following example shows how to make a Continuity Test measurement using SCPI commands.

```
MEASure:CONTinuity?
```

Testing diodes

The diode testing function has the following features:

- Uses a 1 mA \pm 0.2% constant current source.
- Open circuit voltage is limited to less than 4.5 V for all ranges.
- Response time is 60 samples/second.

Make the connection as shown below.

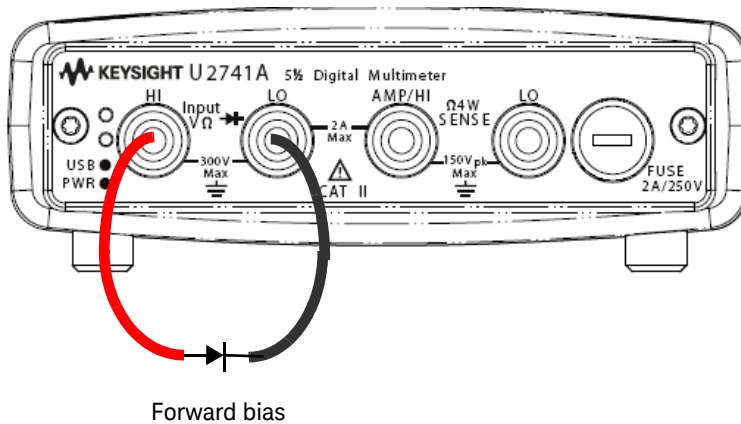

Keysight Measurement Manager operation

Select the **Diode** \rightarrow function. The reading is displayed and updated continuously.

SCPI commands

The following example shows how to make a Diode Test measurement using SCPI commands.

MEASure:DIODE?

Measuring temperature

The temperature measurement function has the following features:

- The measurement range is dependant on the type of temperature sensor used. For the specification details of the temperature sensors, please refer to [Chapter 4, “Characteristics and Specifications”](#).
- Measurements are in auto-range for 5 k Ω thermistor probe.
- Supports the thermistor.

Make the connection as shown below.

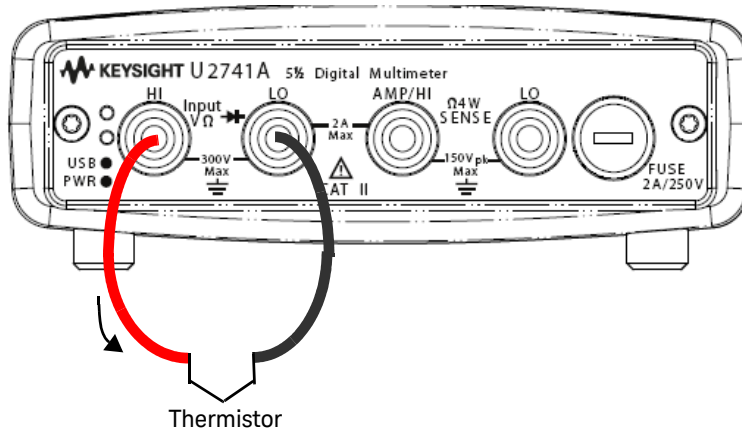

Keysight Measurement Manager operation

Select the **Temp** function and the type of thermistor used. The reading is displayed and updated continuously.

SCPI commands

The following example shows how to make a temperature measurement using SCPI commands.

```
MEASure:TEMPerature? THER //Used for thermistor measurement
```

Restoring Instrument State

The U2741A automatically saves the last configuration whenever a power-down event occurs and restores to the last power-down state when you turn on the instrument.

Autozero

When autozero is *enabled*, the digital multimeter internally disconnects the input signal following each measurement, and takes a *zero reading*. It then subtracts the zero reading from the preceding reading. This prevents offset voltages present on the digital multimeter's input circuitry from affecting measurement accuracy.

This is applicable to DC voltage, DC current, two-wire ohms and temperature measurements only.

SCPI Commands

The following commands are used to set the autozero:

VOLTage:ZERO:AUTO {OFF|ON}

CURRent:ZERO:AUTO {OFF|ON}

RESistance:ZERO:AUTO {OFF|ON}

TEMPerature:ZERO:AUTO {OFF|ON}

Ranging

You can let the digital multimeter automatically select the range using *auto range* or you can select a fixed range using *manual range*. Autoranging is convenient because the digital multimeter automatically selects the appropriate range for each measurement. However, you can use manual range for faster measurements since the digital multimeter does not have to determine which range to use for each measurement.

- Autorange thresholds:

Down range at: <10% of range

Up range at: >120% of range

- For manual range, if the input signal is greater than the present range can measure, the digital multimeter gives an overload indication: “9.9E+37” from the remote interface. For auto range, the digital multimeter will give an overload indication “9.9E+37” if the input signal is greater than the highest measurement range.
- The range is fixed for continuity tests (1 k Ω range) and diode tests (1 VDC range with 1 mA current source output).

SCPI Commands

You can set the range using any of the following commands.

```

CONFigure:<function> {<range>|MIN|MAX|AUTO},
{<resolution>|MIN|MAX|DEF}
MEASure:<function>? {<range>|MIN|MAX|AUTO},
{<resolution>|MIN|MAX|DEF}
<function>:RANGe {<range>|MINimum|MAXimum|AUTO}
<function>:RANGe:AUTO {OFF|ON}

```

Default Settings

The table below summarizes the U2741A's settings as received from the factory, at power-on or following the *RST command received over the USB remote interface.

Table 2-1 Default settings summary

Parameter	Factory Setting	Power-on/Reset State
Measurement Configuration		
Function	DCV	DCV
Range	AUTO	AUTO
Resolution	5.5 digits	5.5 digits
Temperature Unit	°C	User setting
Trigger Operation		
Trigger Source	Auto Trigger	Auto Trigger
System-Related Operation		
Power-Down Recall	Disabled	User Setting
Stored States	0-10 Cleared	No Change
Reading Output Buffer	Cleared	Cleared
Error Queue	Cleared	Cleared
Power-on Status Clear	Enabled	User Setting
Status Registers, Masks & Transition Filter	Cleared	Cleared in power-on status clear enabled
Calibration		
Calibration State	Secured	User Setting
Calibration Value	0	No Change
Calibration String	Cleared	No Change

Triggering the U2741A

At power-up, the default trigger source is immediate. To make a measurement, the following steps are to be followed:

- Configure the U2741A by selecting the function, range, resolution, and so on.
- Specify the digital multimeter's trigger source. You can select software bus trigger or an immediate internal trigger (default trigger source).
- Ensure that the U2741A is in wait-for-trigger state to accept a trigger from the specified source.

Immediate triggering

In the immediate trigger mode, the trigger signal is always present. When you place the U2741A in the wait-for-trigger state, the trigger is issued immediately. This is the default trigger source.

SCPI command

The following command sets the trigger source to immediate:

```
TRIGger:SOURce IMMEDIATE
```

Software bus triggering

The bus trigger mode is initiated by sending a bus trigger command, after selecting BUS as the trigger source.

SCPI command

The following command sets the trigger source to bus:

```
TRIGger:SOURce BUS
```

The **MEASure?** and **READ?** command overwrites the BUS trigger and triggers the digital multimeter and returns a measurement.

The **INITiate** command changes the state of the triggering to wait-for-trigger state. Measurements will begin when the specified trigger conditions are satisfied.

Star Triggering

The star trigger can only be applied when the U2741A is connected into the U2781A modular instrument chassis. It is used to trigger multiple modular units in the chassis.

SCPI command

TRIGger:SOURce STRG

Synchronization Status

This is to configure the synchronization of multiple units of U2741A (slave only) when used in the U2781A modular instrument chassis. Only one master can be assigned at a time.

SCPI command

CONFigure:SSI {NONE|SLAVE}

Refer to the *Keysight U2741A Programmer's Reference* for complete description and syntax for these commands.

System-Related Operation

This section provides information on system-related topics such as performing a self-calibration routine and reading error conditions.

Error conditions

A record of up to 20 errors can be stored in the U2741A's error queue. Refer to the programming guide for more information on the error messages.

Keysight Measurement Manager Operation

A message box will appear once an error occurs while operating the U2741A using the KMM.

THIS PAGE HAS BEEN INTENTIONALLY LEFT BLANK.

3 Measurement Tutorial

DC Measurement Considerations	48
Noise Rejection	49
Resistance Measurement Considerations	52
AC Measurements	55
Other Primary Measurement Functions	57
Other Sources of Measurement Error	59

The Keysight U2741A is capable of making accurate measurements but in order to achieve the best accuracy, you must take the necessary steps to eliminate potential measurement errors. This chapter describes common errors found in measurements and gives suggestions to help you avoid or minimize these errors.

DC Measurement Considerations

Thermal EMF errors

Thermoelectric voltages are the most common source of error in low-level DC voltage measurements. Thermoelectric voltages are generated when you make circuit connections using dissimilar metals at different temperatures.

Each metal-to-metal junction forms a thermocouple, which generates a voltage proportional to the junction temperature. You should take the necessary precautions to minimize thermocouple voltages and temperature variations in low-level voltage measurements. The best connections are formed using copper-to-copper crimped connections, as the digital multimeter's input terminals are copper alloy. The table below shows common thermoelectric voltages for connections between dissimilar metals.

Table 3-1 Thermoelectric voltage for dissimilar metals connections

Copper to -	Approx. mV / °C	Copper to -	Approx. mV / °C
Cadmium-Tin Solder	0.2	Aluminum	5
Copper	<0.3	Tin-Lead Solder	5
Gold	0.5	Kovar or Alloy 42	40
Silver	0.5	Silicon	500
Brass	3	Copper-Oxide	1000
Beryllium	5		

Noise Rejection

Rejecting power-line noise voltages

An important property of integrating analog-to-digital (A/D) converters is their ability to reject power-line related noise that is present on the DC input signals. This is called normal mode noise rejection, or NMR. The digital multimeter achieves NMR by measuring the average DC input by “integrating” it over an integral number of power line cycles.

Common mode rejection (CMR)

Ideally, a digital multimeter is completely isolated from earth-referenced circuits. However, there is a finite resistance between the digital multimeter's input LO terminal and earth ground, as shown below. This can cause errors when measuring low voltages that are floating in relative to earth ground.

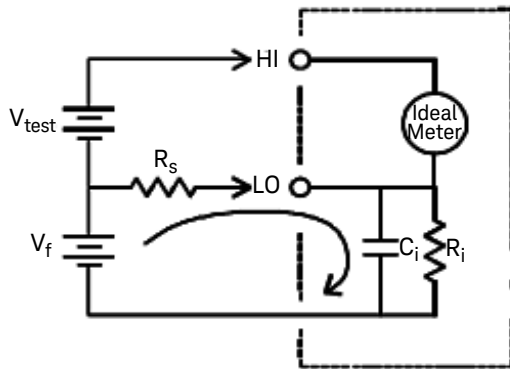

V_f = Float Voltage

R_s = DUT Source Resistance Imbalance

R_i = digital multimeter Isolation Resistance (LO-Earth)

C_i = digital multimeter Input Capacitance

$$\text{Error (v)} = \frac{V_f \times R_s}{R_s + R_i}$$

Figure 3-1 Common mode source error

Noise caused by magnetic loops

If you are making measurements near magnetic fields, it is a good practice to avoid inducing voltages in the measurement connections. Conductor carrying high current is one common source of magnetic field. You can use twisted-pair cable connections to the digital multimeter to reduce the noise pickup loop area, or place the test leads as close together as possible. Loose or vibrating test leads will also induce error voltages. Tie test leads securely when operating near magnetic fields. Whenever possible, use magnetic shielding materials or increase the distance from magnetic sources to minimize this error.

Noise caused by ground loops

When measuring voltages in circuits where the digital multimeter and the device under test are both referenced to a common earth ground, a ground loop is formed. As shown in [Figure 3-2](#), any voltage difference between the two ground reference points (V_{ground}) will cause a current to flow through the measurement leads. This gives rise to noise and offset voltage (usually power-line related), which are added to the measured voltage.

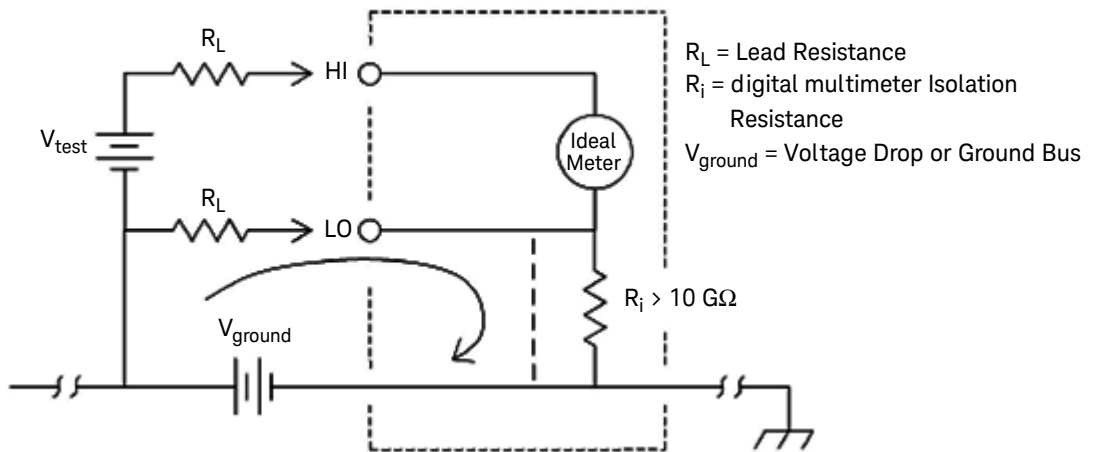

Figure 3-2 Ground loop induced error

The best way to eliminate ground loops is to isolate the digital multimeter from earth by not grounding the input terminals. If the digital multimeter must be earth-referenced, connect it and the device under test to the same common ground point. Also connect the digital multimeter and device under test to the same electrical outlet whenever possible.

Resistance Measurement Considerations

When measuring resistance, the test current flows from the input HI terminal through the resistor being measured. The voltage drop across the resistor being measured is sensed internally in the digital multimeter. Therefore, the test lead resistance is also measured.

The errors mentioned earlier in this chapter for DC voltage measurements also apply to resistance measurements. Additional error sources unique to resistance measurements are discussed here.

Resistance measurements

The Keysight U2741A offers two methods for measuring resistance:

2-wire and *4-wire* ohms. For both methods, the test current flows from the input HI terminal and then through the resistor being measured. For 2-wire ohms, the voltage drop across the resistor being measured is sensed internal to the digital multimeter. Therefore, test lead resistance is also measured. For 4-wire ohms, separate “sense” connections are required. Since no current flows in the sense leads, the resistance in these leads does not give a measurement error.

The errors mentioned earlier in this chapter for DC voltage measurements also apply to resistance measurements. Additional error sources unique to resistance measurements are discussed on the following pages.

4-wire ohms measurements

The 4-wire ohms method provides the most accurate way to measure small resistances. Test lead resistances and contact resistances are automatically reduced using this method. Four-wire ohms is often used in automated test applications where long cable lengths, numerous connections, or switches exist between the digital multimeter and the device-under-test. The recommended connections for 4-wire ohms measurements are shown below.

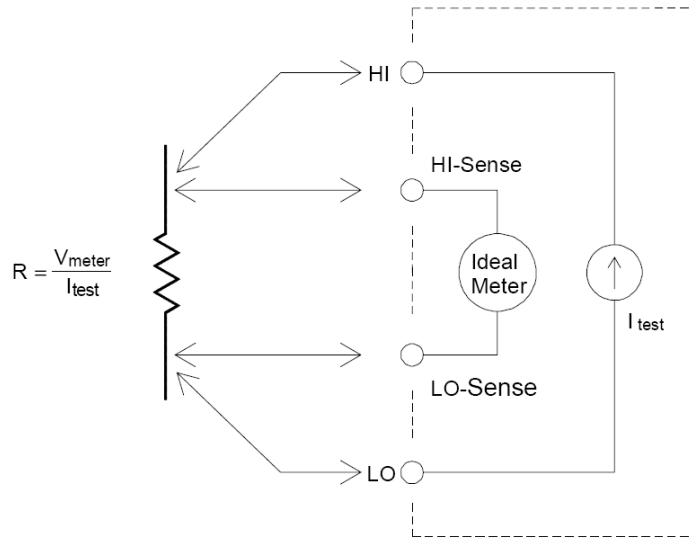

Removing test lead resistance errors

To eliminate offset errors associated with the test lead resistance in 2-wire ohms measurements, follow the steps below.

- 1 Short the tips of the test leads. The reading is the test lead resistance.
- 2 Click Null. The digital multimeter stores the test lead resistance as the 2-wire resistance null value and the digital multimeter will subtract this value from the value of subsequent measurements.

Minimizing power dissipation effects

When measuring resistors designed for temperature measurements (or other resistive devices with large temperature coefficients), be aware that the digital multimeter will dissipate some power in the device under test.

If power dissipation is a problem, you should select the digital multimeter's next higher measurement range to reduce the errors to acceptable levels. The following table shows several examples:

Table 3-2 Power dissipation for various resistance ranges

Range	Test current	DUT power at full scale
100 Ω	1 mA	100 mW
1 k Ω	0.83 mA	689 mW
10 k Ω	100 mA	100 mW
100 k Ω	10 mA	10 mW
1 M Ω	900 nA	810 nW
10 M Ω	205 nA	420 nW
100 M Ω	205 nA 10 M Ω	35 nW

Errors in high resistance measurements

When you are measuring large resistances, significant errors can occur due to insulation resistance and surface cleanliness. You should take the necessary precautions to maintain a “clean” high-resistance system. Test leads and fixtures are susceptible to leakage due to moisture absorption in insulating materials and “dirty” surface films. Nylon and PVC are relatively poor insulators ($10^9 \Omega$) when compared to Polytetrafluoroethylene (PTFE) insulators ($10^{13} \Omega$). Leakage from nylon or PVC insulators can easily contribute a 0.1% error when measuring a 1 M Ω resistance in humid conditions.

AC Measurements





True RMS AC measurements

True RMS responding digital multimeter, like the U2741A, measure the “heating” potential of an applied voltage. Power dissipated in a resistor is proportional to the square of the voltage waveform. This digital multimeter accurately measures true RMS voltage or current, as long as the wave shape contains negligible energy above the instrument's effective bandwidth.

NOTE

The U2741A uses the same techniques to measure true RMS voltage and true RMS current.

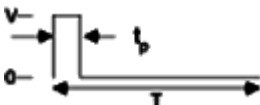
Table 3-3 Waveform shapes and their parameters

Waveform shape	Crest factor (CF)	AC RMS	AC+DC RMS
	$\sqrt{2}$	$\frac{V}{\sqrt{2}}$	$\frac{V}{\sqrt{2}}$
	$\sqrt{3}$	$\frac{V}{\sqrt{3}}$	$\frac{V}{\sqrt{3}}$
	$\frac{T}{\sqrt{t_p}}$	$\frac{V}{CF} \times \sqrt{1 - \left(\frac{1}{CF}\right)^2}$	$\frac{V}{CF}$
	1	V	V

The digital multimeter's AC voltage and AC current functions measure the AC-coupled true RMS value, where only the “heating value” of only the AC components of the input waveform is measured while the DC component is rejected. As seen in the figure above; for sine waves, triangular waves, and square waves, the AC-coupled and AC+DC values are equal, since these waveforms do not contain a DC offset. However, for non-symmetrical waveforms, such as pulse trains, there is a DC voltage content, which is rejected by Keysight's AC-coupled true RMS measurements. This can provide a significant benefit. An AC-coupled true RMS measurement is desirable when you are measuring small AC signals in the presence of large DC offsets.

A good example is measuring AC ripples that are present in DC power supplies. There are situations, however, where you might want to know the AC+DC true RMS value. You can determine this value by combining results from DC and AC measurements, as shown below ([Equation 1](#)):

$$(AC + DC)_{TrueRMS} = \sqrt{AC^2 + DC^2} \quad (1)$$

For the best AC noise rejection, you should perform the DC measurement at 20 NPLC.

True RMS accuracy and high-frequency signal content

A common misconception is that “since an AC digital multimeter is true RMS, its sine wave accuracy specifications apply to all waveforms.” Actually, the shape of the input signal can dramatically affect the measurement accuracy especially when that input signal contains high-frequency components which exceed the instrument's bandwidth.

Other Primary Measurement Functions

Frequency measurement errors

The U2741A uses a reciprocal counting technique to measure frequency. This method generates a constant measurement resolution for any input frequency. All frequency counters are susceptible to errors when measuring low-voltage, low-frequency signals. The effects of both internal noise and external noise pickup are critical when measuring “slow” signals. The error is inversely proportional to frequency. Measurement errors also occur if you attempt to measure the frequency of an input following a DC offset voltage change and therefore, you must allow the digital multimeter’s input to fully settle before making frequency measurements.

DC current measurements

When you connect the digital multimeter in series with a test circuit to measure current, a measurement error is introduced. The error is caused by the digital multimeter's series burden voltage. A voltage is developed across the wiring resistance and current shunt resistance of the digital multimeter, as shown below.

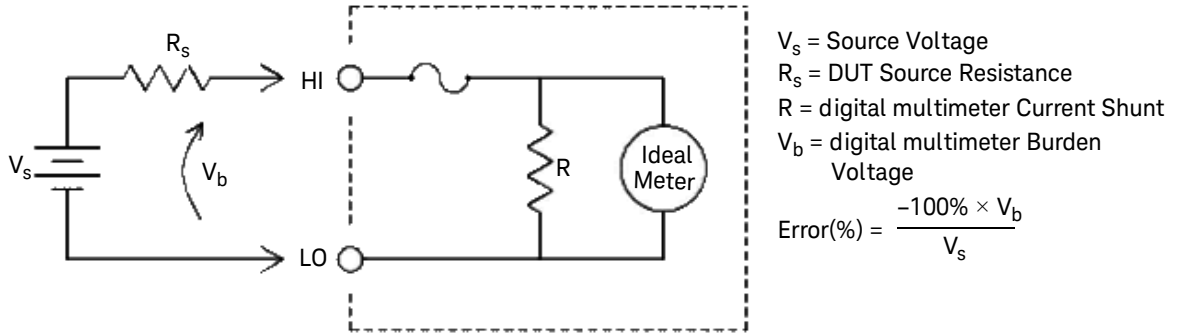

Figure 3-3 Burden voltage in current measurement

Other Sources of Measurement Error

Loading errors (AC volts)

In the AC voltage function, the input of the digital multimeter appears as a 1 M Ω resistance in parallel with 100 pF of capacitance. The cabling that you use to connect signals to the digital multimeter also adds capacitance and loading.

For low frequencies, the loading error is (Equation 2):

$$Error(\%) = \frac{-100 \times R_s}{R_s + 1 \text{ M}\Omega} \quad (2)$$

At high frequencies, the additional loading error is (Equation 3):

$$Error(\%) = 100 \times \left[\frac{1}{\sqrt{1 + (2\pi \times F \times R_s \times C_{in})^2}} - 1 \right] \quad (3)$$

R_s = Source resistance

F = Input frequency

C_{in} = Input capacitance (100 pF) plus cable capacitance

Measurements below full scale

You can make the most accurate AC measurements when the digital multimeter is at or near the full scale of the selected range. Autoranging occurs at 10% (down-range) and 120% (up-range) of full scale. This enables you to measure some inputs at full scale on one range and 10% of full scale on the next higher range. In general, the accuracy is better on the lower range; for the highest accuracy, select the lowest manual range possible for the measurement.

High-voltage self-heating errors

If you apply more than 300 Vrms, self-heating occurs in the digital multimeter's internal signal-conditioning components. These errors are included in the digital multimeter's specifications.

Temperature changes inside the digital multimeter due to self-heating may cause additional error on other AC voltage ranges.

AC current measurement errors (burden voltage)

Burden voltage errors, which apply to DC current, also apply to AC current measurements. However, the burden voltage for AC current is larger due to the digital multimeter's series inductance and your measurement connections. The burden voltage increases as the input frequency increases. Some circuits may oscillate when performing current measurements due to the digital multimeter's series inductance and your measurement connections.

Low-level measurement errors

When measuring AC voltages less than 100 mV, be aware that these measurements are especially susceptible to errors introduced by extraneous noise sources. An exposed test lead acts as an antenna and a properly functioning digital multimeter will measure the signals received. The entire measurement path, including the power line, acts as a loop antenna. Circulating currents in the loop create error voltages across any impedance in series with the digital multimeter's input. For this reason, you should apply low-level AC voltages to the digital multimeter through shielded cables. You should connect the shield to the input LO terminal.

Make sure the digital multimeter and the AC source are connected to the same electrical outlet whenever possible. You should also minimize the area of any ground loops that cannot be avoided. A high-impedance source is more susceptible to noise pickup than a low-impedance source. You can reduce the high-frequency impedance of a source by placing a capacitor in parallel with the digital multimeter's input terminals. You may have to experiment to determine the correct capacitor value for your application.

Most extraneous noise is not correlated with the input signal. You can determine the error as shown below (Equation 4):

$$\text{Voltage Measured} = \sqrt{V_{\text{in}}^2 + \text{Noise}^2} \quad (4)$$

Correlated noise, while rare, is especially detrimental. Correlated noise always adds directly to the input signal. Measuring a low-level signal with the same frequency as the local power line is a common situation that is prone to this error.

4 Characteristics and Specifications

For the characteristics and specifications of the U2741A USB Modular 5.5 Digits Digital Multimeter, refer to the datasheet at <http://literature.cdn.keysight.com/litweb/pdf/5991-0042EN.pdf>.

THIS PAGE HAS BEEN INTENTIONALLY LEFT BLANK.



This information is subject to change without notice. Always refer to the Keysight website for the latest revision.

© Keysight Technologies 2008 - 2017
Edition 10, March 17, 2017

Printed in Malaysia

