

AMPROBE®

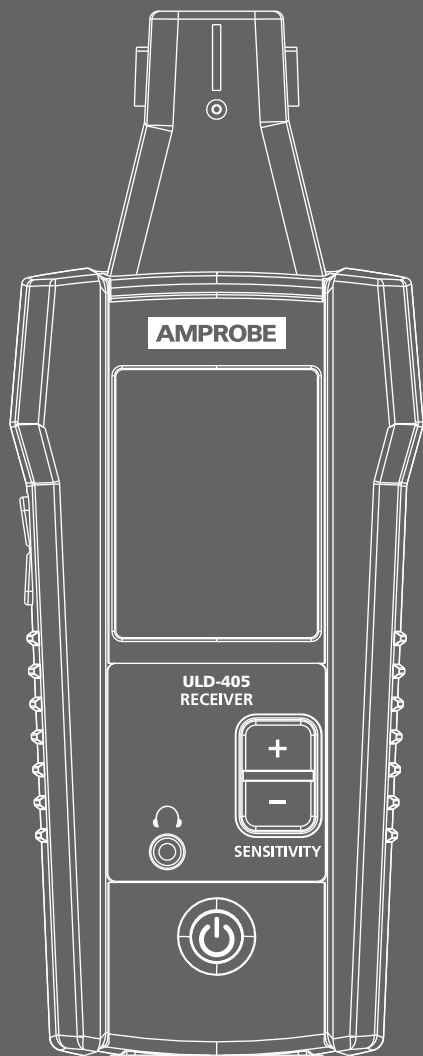

ULD-405 Ultrasonic Leak Detector

User Manual

**Test Equipment
Depot**



1-800-517-8431

5 Commonwealth Ave
Woburn, MA 01801
Phone 781-665-1400
Toll Free 1-800-517-8431



Visit us at www.TestEquipmentDepot.com

AMPROBE®

ULD-405

Ultrasonic Leak Detector

User Manual

Limited Warranty and Limitation of Liability

Your Amprobe product will be free from defects in material and workmanship for one year from the date of purchase unless local laws require otherwise. This warranty does not cover fuses, disposable batteries or damage from accident, neglect, misuse, alteration, contamination, or abnormal conditions of operation or handling. Resellers are not authorized to extend any other warranty on the behalf of Amprobe. To obtain service during the warranty period, return the product with proof of purchase to an authorized Amprobe Service Center or to an Amprobe dealer or distributor. See Repair Section for details. THIS WARRANTY IS YOUR ONLY REMEDY. ALL OTHER WARRANTIES - WHETHER EXPRESS, IMPLIED OR STATUTORY - INCLUDING IMPLIED WARRANTIES OF FITNESS FOR A PARTICULAR PURPOSE OR MERCHANTABILITY, ARE HEREBY DISCLAIMED. MANUFACTURER SHALL NOT BE LIABLE FOR ANY SPECIAL, INDIRECT, INCIDENTAL OR CONSEQUENTIAL DAMAGES OR LOSSES, ARISING FROM ANY CAUSE OR THEORY. Since some states or countries do not allow the exclusion or limitation of an implied warranty or of incidental or consequential damages, this limitation of liability may not apply to you.

Repair

All Amprobe returned for warranty or non-warranty repair or for calibration should be accompanied by the following: your name, company's name, address, telephone number, and proof of purchase. Additionally, please include a brief description of the problem or the service requested and include the test leads with the meter. Non-warranty repair or replacement charges should be remitted in the form of a check, a money order, credit card with expiration date, or a purchase order made payable to Amprobe.

In-warranty Repairs and Replacement – All Countries

Please read the warranty statement and check your battery before requesting repair. During the warranty period, any defective test tool can be returned to your Amprobe distributor for an exchange for the same or like product. Please check the "Where to Buy" section on amprobe.com for a list of distributors near you. Additionally, in the United States and Canada, in-warranty repair and replacement units can also be sent to an Amprobe Service Center (see address below).

Non-warranty Repairs and Replacement – United States and Canada

Non-warranty repairs in the United States and Canada should be sent to an Amprobe Service Center. Call Amprobe or inquire at your point of purchase for current repair and replacement rates.

Non-warranty Repairs and Replacement – Europe







European non-warranty units can be replaced by your Amprobe distributor for a nominal charge. Please check the "Where to Buy" section on beha-amprobe.com for a list of distributors near you.

CONTENTS

1. PRECAUTIONS AND SAFETY MEASURES	2
2. INTRODUCTION	3
3. KIT COMPONENTS.....	4
3.1 Kit Components	4
3.2 ULD-405 Receiver.....	5
3.3 Accessories	6
4. MAIN APPLICATIONS	7
4.1 Using the ULD-405 Ultrasonic Leak Detector Receiver.....	7
5. MAINTENANCE	8
5.1 Changing the Receiver Batteries	8
5.2 Cleaning	8
6. SPECIFICATIONS	9

1. PRECAUTIONS AND SAFETY MEASURES

SYMBOLS

	Caution! Refer to the explanation in this manual.
	Consult user documentation.
	Battery.
	Complies with European Directives.
	Conforms to relevant South Korean EMC Standards. Electromagnetic Compatibility: Korea (KCC): Class A Equipment (Industrial Broadcasting & Communication Equipment) ⁽¹⁾ ⁽¹⁾ This product meets requirements for industrial (Class A) electromagnetic wave equipment and the seller or user should take notice of it. This equipment is intended for use in business environments and is not to be used in homes.
	Conforms to relevant Australian standards.
	This product complies with the WEEE Directive marking requirements. The affixed label indicates that you must not discard this electrical/electronic product in domestic household waste. Product Category: With reference to the equipment types in the WEEE Directive Annex I, this product is classed as category 9 “Monitoring and Control Instrumentation” product. Do not dispose of this product as unsorted municipal waste.

Safety information

The product complies with:

- IEC 61326-1

CENELEC Directives

The instrument conforms to CENELEC Electromagnetic compatibility directive 2014/30/EU.

WARNINGS AND PRECAUTIONS

- Not for use on explosive gases.
- Use extreme care when using near pressurized air/gas.
- Use extreme care when using near rotation equipment.
- Use extreme care when using near electrical equipment.
- Use only 4 x AA batteries for the ULD-405 Receiver, properly installed in the battery compartment, to power the Product (see Section 5: Maintenance).
- Remove the batteries if the Product is not used for an extended period of time, or if stored in temperatures above 122 °F (50 °C). If the batteries are not removed, battery leakage can damage the Product.
- Follow all battery care from the battery manufacturer.

2. INTRODUCTION

Ultrasonic sound, or ultrasound, is a sound wave with frequencies above 20 kHz, higher than the upper audible limit of human hearing. Ultrasound can be generated when turbulence created by air or gas is forced through a small orifice. Leaking air or gas is generally considered to be viscous flow, and as the flow velocity increases, the frequency of the ultrasound emitted becomes higher. Vibrating, moving objects or electric discharge will also create an ultrasonic wave, which is very directional in nature and can be used to pinpoint the exact location of a leak, vibration or discharge.

The ULD-405 Receiver detects ultrasounds within 20 kHz to 90 kHz frequency, then amplifies and converts these ultrasonic sounds to frequencies and levels that the human ear can hear through headphones and show it on the LCD screen. The 20 kHz to 90 kHz frequency range is the optimal range for detecting a variety of leakage events in assets such as HVAC systems and pneumatic lines. A change in the ultrasound produced by an asset may be indicative that an asset is beginning to fail.

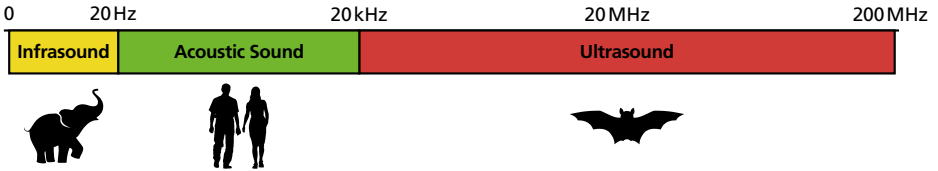

Figure 2: Sound range spectrum

3. KIT COMPONENTS

3.1 Kit Components

Your shipping box should include:

	ULD-405
ULD-405 Receiver	1
Earbuds (for use with hard hat)	1
PB-1 Power Parabola	1
TEA-1 Flexible Tubing Adapter	1
TE-1 Tubular Extension	1
CC-6010 Carrying Case	1
AA Batteries	4
Manual	1

Note: Batteries are not pre-installed in the Receiver.

3. KIT COMPONENTS

3.2 ULD-405 Receiver

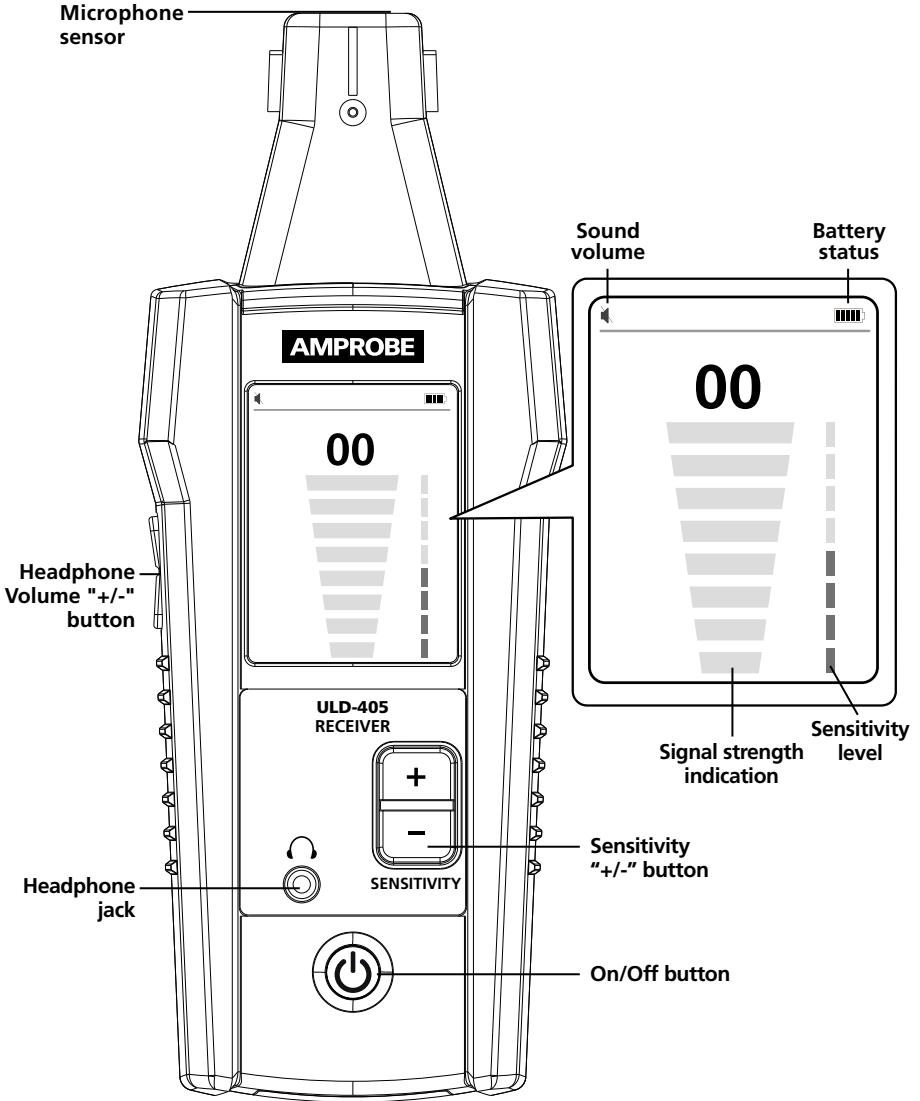

Figure 3.2: ULD-405 Receiver

3. KIT COMPONENTS

3.3 Accessories

The ULD-405 comes supplied with additional Receiver accessories that are helpful in leak identification. Plug the headphones into the Receiver to audibly hear the leak and verify its source (for example hissing sound of an air leak versus ticking sound of an electric discharge). Use the Parabola attachment in situations where there is a high level of background noise to help direct the ultrasound towards the sensor. Use the Tubular Extension with the Adapter in hard to reach areas for additional reach.

Note: There is no speaker on the Receiver. Without headphones, no noise will be audible.

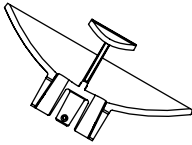

Parabola (PB-1)

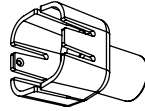

Adapter (TEA-1)

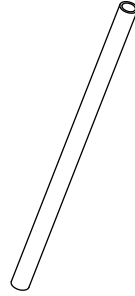

Tubular Extension
(TE-1)

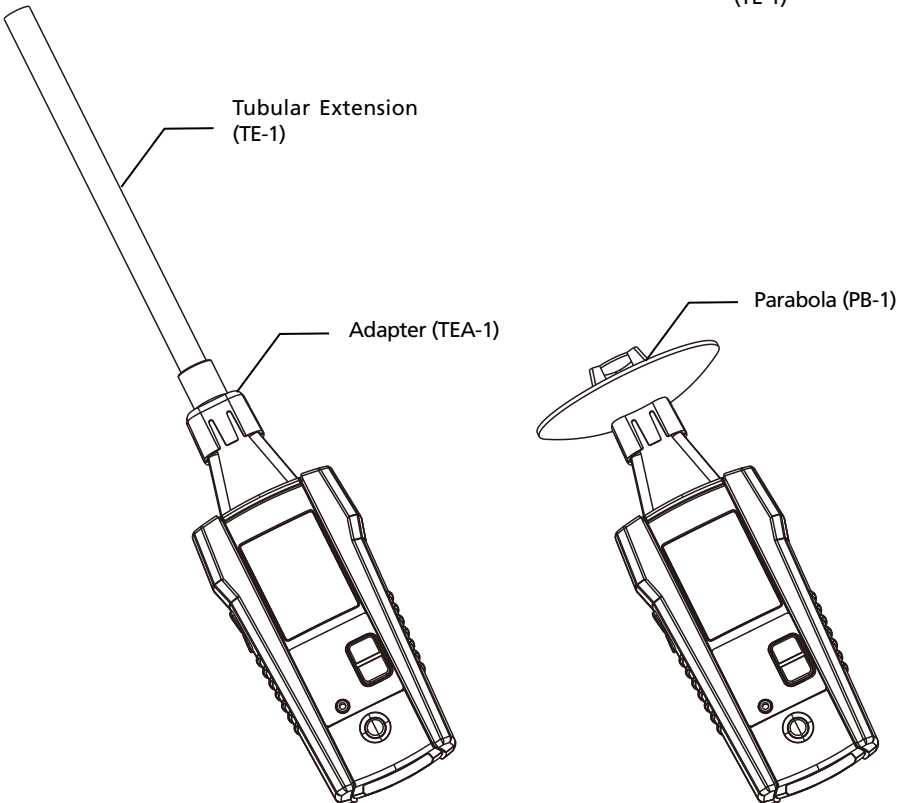

Figure 3.3: ULD-405 Accessories

4. MAIN APPLICATIONS

4.1 Using the ULD-405 Ultrasonic Leak Detector Receiver

1. Turn on the Receiver and plug the headphones into the jack located on the front of the Receiver. Any standard set of 3.5 mm jack headphones are compatible.
2. Before moving to the target area, press "+" or "-" sensitivity buttons to adjust signal strength sensitivity to the highest possible level where bargraph still shows either 0 or a value close to 0. If signal strength cannot be adjusted down and the LCD still shows a maximum value regardless on sensitivity adjustments, press the Filter button.*
3. Scan the target area with the microphone sensor.
4. As you move nearer to the source of the leak, vibration or electric discharge, the signal strength will increase. This will be indicated on a screen with increasing signal strength number and level of the bargraph.
5. The bargraph is a relative measurement only, so when the signal strength reaches maximum, lower the sensitivity by pressing the "-" sensitivity button until the displayed signal strength is less than 75. Repeat this process until you have isolated the source of the ultrasound.
6. The audible sound emitted via headphones will help to verify the source of the leak, for example hissing sound of the air leak versus ticking sound of the electric discharge. The Receiver screen alone will not provide an indication of the leak source.

Note:

- For surroundings with a high level of background noise use the Parabola (PB-1) to direct the ultrasound towards the sensor.
- For locations that you cannot point the Receiver directly at the leak, the Tubular Extension can be used (TE-1 with the TEA-1 Adapter).

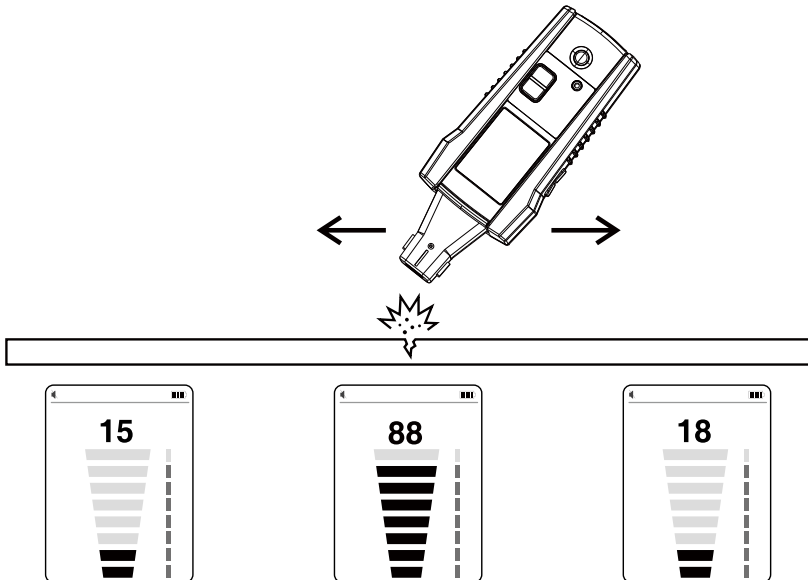

Figure 4.1: Using the Receiver to find a leak

5. MAINTENANCE

5.1 Changing the Receiver Batteries

The ULD-405 uses four 1.5 V AA (LR6) batteries (supplied). To replace the batteries, follow these steps:

1. Make sure that the Receiver is turned off.
2. Use a screw driver to unscrew the captive screw.
3. Remove the battery cover.
4. Replace the batteries as shown in Figure 5.1. Observe the battery polarity shown in the battery compartment.
5. Replace the battery cover and secure it with the provided screw.

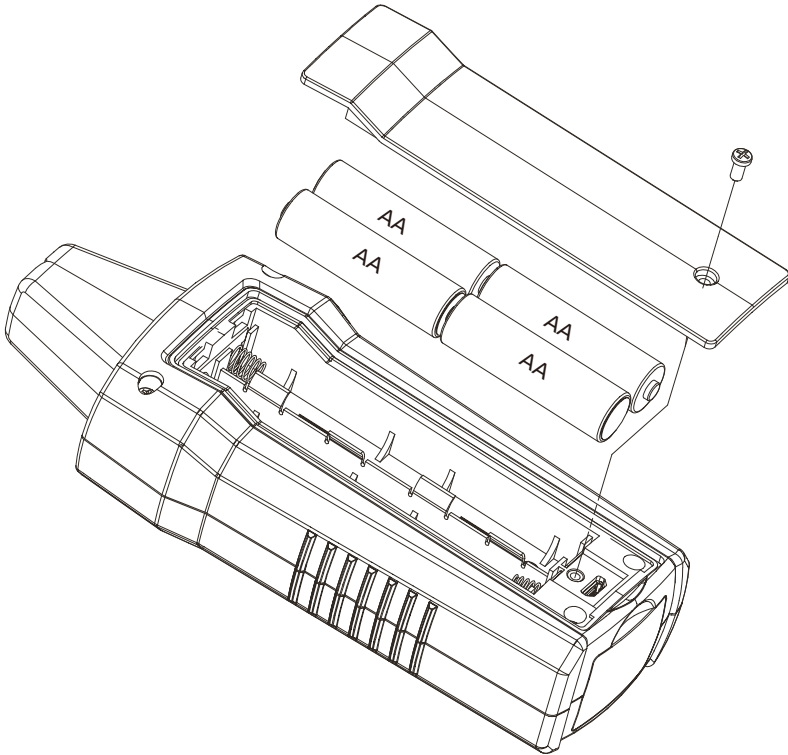



Figure 5.1: Changing the Receiver batteries

5.2 Cleaning

The only maintenance the ULD-405 requires is inspection and cleaning. Periodically wipe the exterior with a mild solution of detergent and water. Apply sparingly with a soft cloth and allow to dry completely before using. Do not use aromatic hydrocarbons, gasoline or chlorinated solvents for cleaning.

6. SPECIFICATIONS

Features	ULD-405
Sensitivity Adjustment	Yes
Volume Adjustment	Yes
Earphone Jack	Yes (compatible with 3.5 mm audio jack)
Display Size	LCD 2.5 in (6.35 cm)
Display Dimensions	1.45 x 1.93 in (36.72 x 48.96 mm)
Display Resolution	240(RGB) x 320 pixels
Display Type	TFT-LCD (262 K)
Display Color	True, 16bit/color
Frequency Range	20 kHz to 90 kHz
Power Supply	4 x 1.5 V AA (LR6) alkaline batteries
Power Consumption (typical)	75 mA
Battery Life (typical)	105 hours (Alkaline)
Low battery indication	
APO function	60 minutes when in idle
Weight	Approx. 0.518 lb (0.235 kg)
Dimensions	7.547 x 2.984 x 1.791 in (183 x 75 x 43 mm)
Operating Temperature	-4 °F to 122 °F (-20 °C to 50 °C)
Storage Temperature	-4 °F to 158 °F (-20 °C to 70 °C)
Operating Humidity	<80% RH
Pollution Degree	2
Protection	IP40
Certifications	
Electromagnetic Compatibility (EMC)	<p>EN 61326-1 Korea (KCC): Class A Equipment (Industrial Broadcasting & Communication Equipment) ^[1]</p> <p>^[1] This product meets requirements for industrial (Class A) electromagnetic wave equipment and the seller or user should take notice of it. This equipment is intended for use in business environments and is not to be used in homes.</p>



5 Commonwealth Ave
Woburn, MA 01801
Phone 781-665-1400
Toll Free 1-800-517-8431

 Visit us at www.TestEquipmentDepot.com