



**Test Equipment  
Depot**  
1-800-517-8431

5 Commonwealth Ave  
Woburn, MA 01801  
Phone 781-665-1400 Toll  
Free 1-800-517-8431

Visit us at [www.TestEquipmentDepot.com](http://www.TestEquipmentDepot.com)

**VALOR<sup>®</sup>1000**  
Compact Bench Scales



Supports  
HACCP Systems

## **Reliable Food-Safe Scale for Dry Environments**

With a food-safe design that is NSF-certified and supports a HACCP system, the Valor 1000 Series is a reliable choice for general food weighing. Easy-to-operate Valor 1000 scales feature two-button operation, a large backlit LCD display and up to 1,500-hour battery life.

### **Unique Features:**

- NSF certified, USDA-AMS accepted design supports HACCP systems, making Valor 1000 perfect for food preparation tasks. Stainless steel pans and plastic in-use covers available for extra protection.
- Save money on batteries. Energy-efficient design operates for up to 1,500 hours.
- Intuitive two-button operation allows for quick weight checking to simplify repetitive operations and increase operator efficiency.

# VALOR®1000 - V12P Compact Bench Scales

Model	V12P3	V12P6	V12P15	V12P30
Capacity × Readability (Max x d non-approved)	6 lb x 0.001 lb 3 kg x 0.0005 kg 3,000 g x 0.5 g 96 oz x 0.02 oz 6 lb x 0.02 oz	15 lb x 0.002 lb 6 kg x 0.001 kg 6,000 g x 1 g 240 oz x 0.05 oz 15 lb x 0.05 oz	30 lb x 0.005 lb 15 kg x 0.002 kg 15,000 g x 2 g 480 oz x 0.1 oz 30 lb x 0.1 oz	60 lb x 0.01 lb 30 kg x 0.005 kg 30,000 g x 5 g 960 oz x 0.2 oz 60 lb x 0.2 oz
Maximum Display Resolution (gram)	1:6,000		1:7,500	1:6,000
Maximum Display Resolution (pound)	1:6,000	1:7,500	1:6,000	
Weighing Units	g, kg, lb, oz, lb:oz			
Application Mode	Weighing			
Tare Range	To capacity by subtraction			
Stabilization Time	≤ 2 seconds			
Power Requirements	AC adapter (included)			
Calibration	Digital with external weight			
Typical Battery Life	1500 hours (with backlight turned off)			
Construction	ABS plastic housing, stainless steel pan, in-use cover			
Safe Overload	150% of capacity			
Specified Temperature Range	32 to 104 °F / 0 to 40 °C			
Display Type	Single display - LCD with white backlight			
Display Size	1.0 in / 25.4 mm			
Pan Size	9.65 x 7.48 in / 245 x 190 mm			
Scale Dimensions (W x D x H)	10.2 x 10.6 x 4.8 in / 260 x 270 x 122 mm			
Shipping Dimensions (W x D x H)	12.6 x 12.6 x 6.9 in / 319 x 319 x 175 mm			
Net Weight	5.5 lb / 2.5 kg			
Shipping Weight	6.8 lb / 3.1 kg			

## Other Standard Features and Equipment

Integrated level bubble and adjustable feet, selectable Auto-Off, selectable weighing units and integrated carrying handles for easy transportation

## Compliance

- **Product Safety:** IEC/EN 61010-1; UL certified power supply
- **Electromagnetic Compatibility:** FCC Part 15 Class B; Canada ICES-003 Class B
- **Food Safety:** NSF/ANSI 169, NSF/ANSI /3-A 14159-1
- **Compliance Marks:** NSF, USDA-AMS

## Accessories

- In-use Cover (1) .....30559105
- In-use Cover (10) .....30559106
- Stainless Steel Platform, 11.8 in x 8.9 in, 300 x 225 mm ....30559107

## Outline Dimensions

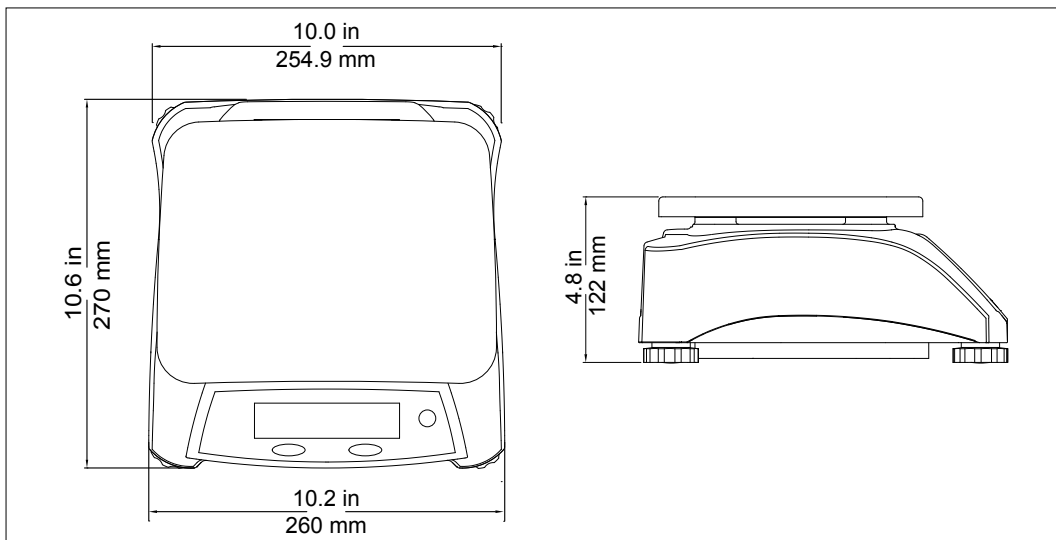

80776386\_1 20200908 © Copyright OHAUS Corporation

